

# ASSEMBLY INSTRUCTIONS

ITEM #DJ89001 | **HOLM CHANDELIER**

## ITEM DESCRIPTION

MATERIAL TYPE: STEEL, GLASS FINISH : PEWTER + CLEAR RIBBED GLASS + GREY GLASS TOP COAT/SEALANT  
 SOCKET TYPE: E26 CERAMIC SOCKET QTY: 8PCS  
 BULB TYPE: TYPE A BULB WATTAGE: 60W or/CFL 16W or/LED 13W VOLTAGE: 110V-120V  
 ITEM NET WEIGHT:

UL COMPLIANT

INSTALLATION ENVIRONMENT: SUITABLE FOR DAMP LOCATIONS



### NOTE:

- \*YOUR PRODUCT(S) MAY BE PACKED IN MORE THAN ONE CARTON
- \*THIS ITEM MAY REQUIRE PERIODIC TIGHTENING

## PARTS

<b>A</b>	LAMP BODY	1 PC
<b>B</b>	WIRE	1 PC
<b>C, D, E, F</b>	ROD	4PCS
<b>G</b>	COUPLER	1 PC
<b>H</b>	CANOPY	1 PC
<b>I</b>	WASHER	2PCS
<b>J</b>	HEX. NUT	2PCS
<b>K</b>	MOUNTING PLATE	1PC
<b>L</b>	MOUNTING SCREW	2PCS
<b>M1</b>	STRENGTHEN SCREWS	4PCS
<b>M2</b>	FLAT HEAD SCREW	4PCS
<b>N</b>	WIRE CONNECTOR	3PCS
<b>O</b>	OUTER GLASS SHADE	8PCS
<b>P</b>	PLASTING RING	24PCS
<b>Q</b>	METAL RING	8PCS
<b>R</b>	INNER GLASS SHADE	8PCS
<b>S</b>	METAL RING	8PCS
<b>I</b>	BULB(NOT INCLUDED)	8PCS

## INCLUDED ASSEMBLY HARDWARE

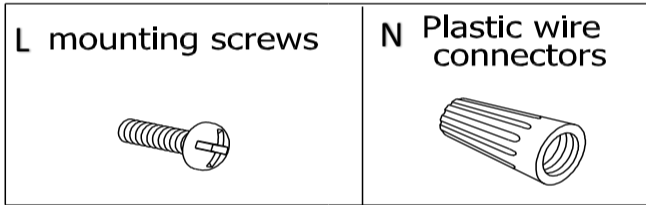

## PRODUCT ASSEMBLY

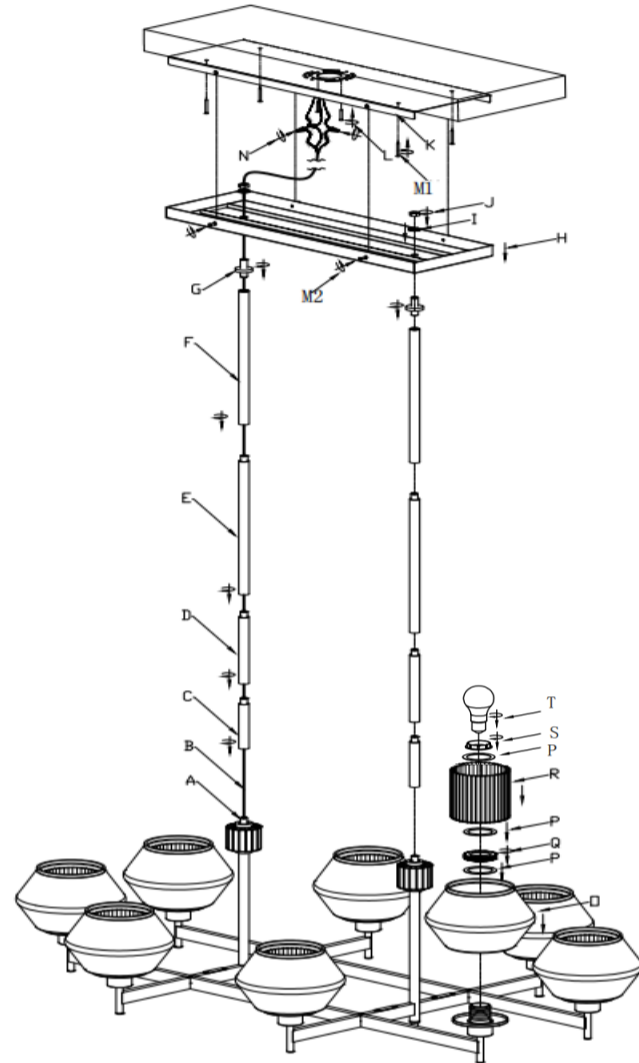

## ASSEMBLY INSTRUCTIONS

1. REMOVE ALL PACKING CONTENTS AND PARTS FROM THE CARTON(S) CAREFULLY
2. PLEASE BE SURE YOU HAVE ALL PARTS INDICATED BEFORE YOU BEGIN ASSEMBLY
3. SCREW THE STEEL ROD (C) ,(D) ,(E) AND (F) TO THE LAMP BODY(A) TILL TIGHT.
4. SCREW THE COUPLER(G) TO THE STEEL ROD(F) TILL TIGHT, ATTACH THE CANOPY(H) INTO THE COUPLER(G) BY USING ENCLOSED WASHER(I) AND HEX. NUT(J) THEN TIGHTEN HEX. NUT(J) WITH SPANNER.
5. SHUT OFF THE MAIN ELECTRICAL SUPPLY FROM THE MAIN FUSE BOX/CIRCUIT BREAKER.
6. ATTACH THE MOUNTING PLATE (K) TO THE OUTLET BOX SECURE WITH THE STRENGTHEN SCREWS(M1) AND MOUNTING SCREW(L).
7. CAREFULLY INSPECT THE PENDANT'S FIXTURE WIRES. THE NEUTRAL FIXTURE WIRE HAS VERY FINE RIDGES MOLDED INTO ITS PLASTIC COVERING. THE HOT FIXTURE WIRE HAS A SMOOTH COVERING. THE BARE SILVER WIRE IS THE GROUNDED WIRE
8. ATTACH THE GROUND WIRE FROM THE FIXTURE TO THE GROUND JUNCTION BOX WIRE FROM THE OUTLET (USUALLY GREEN OR BARE WIRE). FASTEN EACH TOGETHER WITH A PLASTIC WIRE CONNECTOR (N) AND WRAP THE CONNECTION WITH ELECTRICAL TAPE. IF YOUR OUTLET BOX DOES NOT HAVE A GROUND WIRE, INSERT THE GREEN GROUND SCREW INTO THE MOUNTING PLATE (K) FACING DOWN, AND WRAP THE FIXTURE'S BARE GROUND WIRE AROUND THE GROUND SCREW. **IT IS IMPERATIVE THAT THE OUTLET BOX IN YOUR HOME BE PROPERLY GROUNDED.**
9. CONNECT THE NEUTRAL FIXTURE WIRE TO THE NEUTRAL JUNCTION BOX WIRE (USUALLY WHITE). FASTEN EACH TOGETHER WITH A WIRE CONNECTOR (N) AND WRAP THE CONNECTION WITH ELECTRICAL TAPE. BE SURE NO STRANDS ARE EXPOSED.
10. CONNECT THE HOT FIXTURE WIRE TO THE HOT JUNCTION BOX WIRE (USUALLY BLACK). FASTEN EACH TOGETHER WITH A PLASTIC WIRE CONNECTOR (N) AND WRAP THE CONNECTION WITH ELECTRICAL TAPE. BE SURE NO WIRE STRANDS ARE EXPOSED. **DO NOT REVERSE THE HOT AND NEUTRAL CONNECTIONS OR SAFETY WILL BE COMPROMISED.**
11. GENTLY TUCK THE WIRE CONNECTIONS NEATLY INTO THE CEILING JUNCTION BOX.
12. ATTACH THE CANOPY (H) TO THE MOUNTING PLATE (K) USING THE ENCLOSED FLAT HEAD SCREWS(M2). SECURE THE CANOPY BY TIGHTENING 4PCS SCREWS(M2).
13. PUT THE GREY OUTER GLASS(O) & PLASTIC RING(P) TO THE SOCKET AND SECURE GLASS WITH ENCLOSED METAL RING (Q), AND THEN ATTACH PLASTIC RING(P) , INNER RIBBED GLASS(R) AND PLASTIC RING(P) TO THE SOCKET IN TURN AND SECURE GLASS WITH ENCLOSED METAL RING (S).
14. INSTALL 8PCS TYPE A 60W BULBS(OR CFL 16W/LED 13W BULBS, NOT INCLUDED) INTO SOCKET. **DO NOT EXCEED SPECIFIED WATTAGE.**
15. RESTORE POWER TO THE JUNCTION BOX AND TEST FIXTURE.

## CARE & MAINTENANCE

DUST WITH A DRY CLOTH.

FOR CUSTOMER SERVICE QUESTIONS CALL 1.888.488.8866

ARTERIOS HOME: 972.488.9800

ARTERIOS CONTRACT: 972.488.9800 EXT.321

## DISCLAIMERS

WE RECOMMEND THE INSTALLATION OF THIS ELECTRICAL LIGHT FIXTURE TO BE DONE BY A

LICENSED ELECTRICIAN.

# ARTERIOS