

# ASSEMBLY INSTRUCTIONS

ITEM #DJ49008 | **HOLM PENDANT**

## ITEM DESCRIPTION

MATERIAL TYPE: STEEL, GLASS FINISH : PEWTER + CLEAR RIBBED GLASS + GREY GLASS TOP COAT/SEALANT:  
 SOCKET TYPE: E12 CERAMIC SOCKET QTY: 3PCS  
 BULB TYPE: TYPE B BULB WATTAGE: 60W or/CFL 16W or/LED 13W VOLTAGE: 110V-120V  
 ITEM NET WEIGHT:

UL COMPLIANT

INSTALLATION ENVIRONMENT: SUITABLE FOR DAMP LOCATIONS



### NOTE:

- \*YOUR PRODUCT(S) MAY BE PACKED IN MORE THAN ONE CARTON
- \*THIS ITEM MAY REQUIRE PERIODIC TIGHTENING

## PARTS

<b>A</b>	GREY OUTER GLASS	1 PC
<b>B</b>	INNER RIBBER GLASS	1 PC
<b>C</b>	PLASTIC RING	1 PC
<b>D</b>	METAL RING	1 PC
<b>E</b>	THUMB-SCREW	6pcs
<b>F</b>	CANOPY	1 PC
<b>G,H,I</b>	ROD	4pcs
<b>J</b>	LAMP BODY	1 PC
<b>K</b>	MOUNTING PLATE	1 PC
<b>L</b>	MOUNTING SCREW	2 PCS
<b>N</b>	BULB(NOT INCLUDED)	2 PCS
<b>O</b>	CANOPY SCREW	3 PCS

## PRODUCT ASSEMBLY

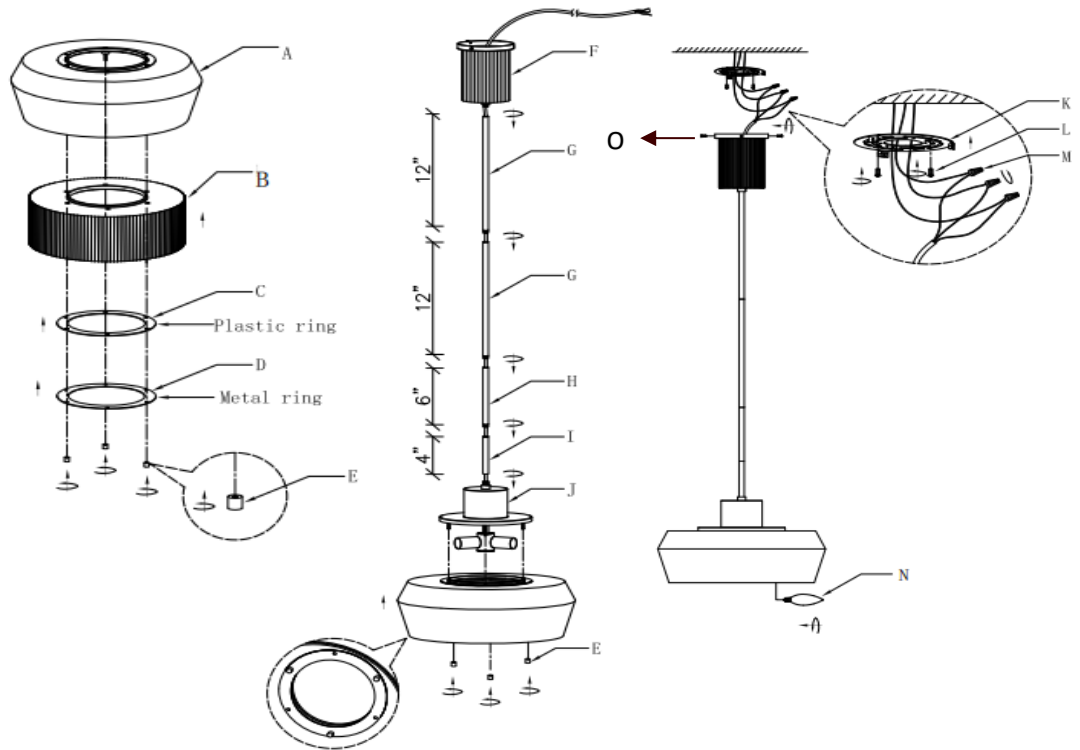

## INCLUDED ASSEMBLY HARDWARE

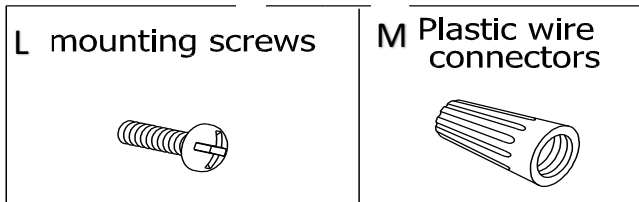

## ASSEMBLY INSTRUCTIONS

1. REMOVE ALL PACKING CONTENTS AND PARTS FROM THE CARTON(S) CAREFULLY
2. PLEASE BE SURE YOU HAVE ALL PARTS INDICATED BEFORE YOU BEGIN ASSEMBLY
3. PUT THE GREY OUTER GLASS(A) UPSIDE DOWN ON A CLEAN AND FLAT AREA, ATTACH METING RING (D), INNER RIBBED GLASS(B) AND PLASTIC RING(C) TO THE GREY OUTER GLASS(A) AND SECURE WITH PROVIDED 3PCS THUMB-SCREWS(E).
4. THEN ATTACH THE OUTER GLASS SHADE (A) TO LAMP BODY(J) AND SECURE WITH PROVIDED 3PCS THUMB-SCREWS(E).
5. SCREW THE STEEL ROD (G), (H) AND (I) TO THE LAMP BODY(J).
6. SCREW THE CANOPY(F) TO THE STEEL ROD(G).
7. SHUT OFF THE MAIN ELECTRICAL SUPPLY FROM THE MAIN FUSE BOX/CIRCUIT BREAKER.
8. ATTACH THE MOUNTING PLATE (K) TO THE OUTLET BOX USING THE MOUNTING SCREWS(L).
9. CAREFULLY INSPECT THE PENDANT'S FIXTURE WIRES. THE NEUTRAL FIXTURE WIRE HAS VERY FINE RIDEGS MOLDED INTO ITS PLASTIC COVERING. THE HOT FIXTURE WIRE HAS A SMOOTH COVERING. THE BARE SILVER WIRE IS THE GROUNDED WIRE
10. ATTACH THE GROUND WIRE FROM THE FIXTURE TO THE GROUND JUNCTION BOX WIRE FROM THE OUTLET (USUALLY GREEN OR BARE WIRE). FASTEN EACH TOGETHER WITH A PLASTIC WIRE CONNECTOR (M) AND WRAP THE CONNECTION WITH ELECTRICAL TAPE. IF YOUR OUTLET BOX DOES NOT HAVE A GROUND WIRE, INSERT THE GREEN GROUND SCREW INTO THE MOUNTING PLATE (A) FACING DOWN, AND WRAP THE FIXTURE'S BARE GROUND WIRE AROUND THE GROUND SCREW. **IT IS IMPERATIVE THAT THE OUTLET BOX IN YOUR HOME BE PROPERLY GROUNDED.**
11. CONNECT THE NEUTRAL FIXTURE WIRE TO THE NEUTRAL JUNCTION BOX WIRE (USUALLY WHITE). FASTEN EACH TOGETHER WITH A WIRE CONNECTOR (M) AND WRAP THE CONNECTION WITH ELECTRICAL TAPE. BE SURE NO STRANDS ARE EXPOSED.
12. CONNECT THE HOT FIXTURE WIRE TO THE HOT JUNCTION BOX WIRE (USUALLY BLACK). FASTEN EACH TOGETHER WITH A PLASTIC WIRE CONNECTOR (M) AND WRAP THE CONNECTION WITH ELECTRICAL TAPE. BE SURE NO WIRE STRANDS ARE EXPOSED. DO NOT REVERSE THE HOT AND NEUTRAL CONNECTIONS OR SAFETY WILL BE COMPROMISED.
13. GENTLY TUCK THE WIRE CONNECTIONS NEATLY INTO THE CEILING JUNCTION BOX.
14. ATTACH THE CANOPY (F) TO THE MOUNTING PLATE (K) USING THE ENCLOSED CANOPY SCREWS(O). SECURE THE CANOPY BY TIGHTENING 3 CANOPY SCREWS(O).
15. INSTALL 3PCS TYPE B 60W BULB(OR CFL 16W/LED 13W BULBS, NOT INCLUDED) INTO SOCKET. **DO NOT EXCEED SPECIFIED WATTAGE.**
16. RESTORE POWER TO THE JUNCTION BOX AND TEST FIXTURE.

## CARE & MAINTENANCE

DUST WITH A DRY CLOTH.

FOR CUSTOMER SERVICE QUESTIONS CALL 1.888.488.8866

ARTERIOS HOME: 972.488.9800

ARTERIOS CONTRACT: 972.488.9800 EXT.321

## DISCLAIMERS

WE RECOMMEND THE INSTALLATION OF THIS ELECTRICAL LIGHT FIXTURE TO BE DONE BY A LICENSED ELECTRICIAN.

# ARTERIOS