

ASSEMBLY INSTRUCTIONS

ITEM #DJ49006 | PIETRO SCONCE

ITEM DESCRIPTION

MATERIAL TYPE: STEEL, GLASS FINISH: ENGLISH BRONZE, CAST CLEAR GLASS TOP COAT/SEALANT:
 SOCKET TYPE: LED SOCKET QTY: 2PCS
 BULB TYPE: LED BULB WATTAGE: LED 8.5W VOLTAGE: 100V-240V
 ITEM NET WEIGHT:
 UL COMPLIANT
 INSTALLATION ENVIRONMENT: SUITABLE FOR DAMP LOCATIONS



NOTE:
 *YOUR PRODUCT(S) MAY BE PACKED IN MORE THAN ONE CARTON
 *THIS ITEM MAY REQUIRE PERIODIC TIGHTENING

PARTS

| | | |
|----------|----------------|-------|
| A | MOUNTING PLATE | 1 PC |
| B | LAMP BODY | 1 PC |
| C | SET SCREW | 2 PCS |
| D | GLASS COVER | 2 PCS |
| E | METAL BAND | 3 PCS |
| F | THUMB-SCREW | 3 PCS |

INCLUDED ASSEMBLY HARDWARE

J mounting screws



K Plastic wire connectors

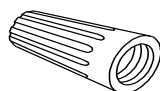

PRODUCT ASSEMBLY

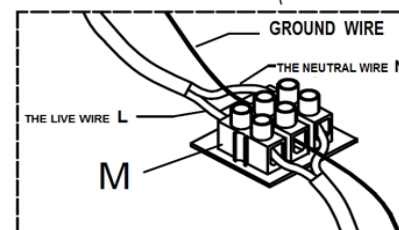
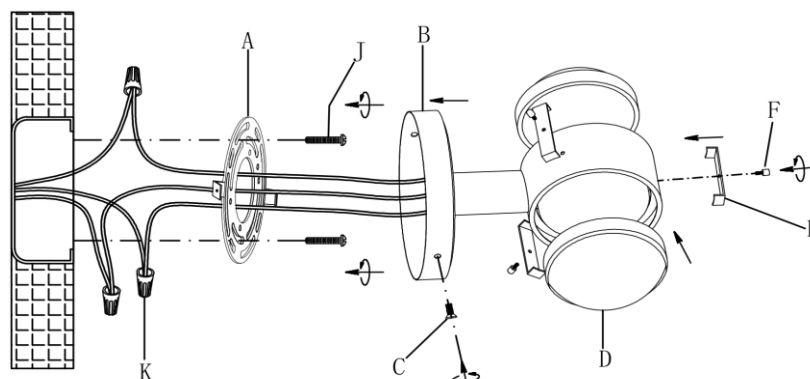

PLEASE IGNORE THIS DEVICE IN THE BACK PLATE

ASSEMBLY INSTRUCTIONS

1. REMOVE ALL PACKING CONTENTS AND PARTS FROM THE CARTON(S) CAREFULLY.
2. PLEASE BE SURE YOU HAVE ALL PARTS INDICATED BEFORE YOU BEGIN ASSEMBLY.
3. SHUT OFF THE MAIN ELECTRICAL SUPPLY FROM THE MAIN FUSE BOX/CIRCUIT BREAKER.
4. ATTACH 2PCS OF THE GLASS COVER(D) ONTO THE LAMP BODY(B) AND SECURE THEM WITH 3PCS OF METAL BAND(E), THEN FIX METAL BAND(E) BY TIGHTENING 3PCS THUMB-SCREWS(F) IN A CLOCKWISE DIRECTION.
5. PULL THE ELECTRICAL CORD OF "J BOX" THROUGH THE EXIT HOLE OF THE MOUNTING PLATE(A).
6. **PLEASE PAY SPECIAL ATTENTION THAT YOU DO NOT NEED TO CONNECT THE WIRE CONNECT DEVICE(M). IT IS USED FOR THE WIRE CONNECTION FOR EURO-MARKET.**
7. CAREFULLY INSPECT THE FIXTURE WIRES. THE NEUTRAL FIXTURE WIRE HAS VERY FINE RIDGES MOLDED INTO ITS PLASTIC COVERING. THE HOT FIXTURE WIRE HAS A SMOOTH COVERING. THE BARE WIRE IS THE GROUNDED WIRE.
8. ATTACH THE GROUND WIRE FROM THE FIXTURE TO THE GROUND JUNCTION BOX WIRE FROM THE OUTLET (USUALLY GREEN OR BARE WIRE). FASTEN EACH TOGETHER WITH A PLASTIC WIRE CONNECTOR (K) AND WRAP THE CONNECTION WITH ELECTRICAL TAPE. IF YOUR OUTLET BOX DOES NOT HAVE A GROUND WIRE, INSERT THE GREEN GROUND SCREW INTO THE MOUNTING PLATE (A) FACING DOWN, AND WRAP THE FIXTURE'S BARE GROUND WIRE AROUND THE GROUND SCREW. **IT IS IMPERATIVE THAT THE OUTLET BOX IN YOUR HOME BE PROPERLY GROUNDED.**
9. CONNECT THE NEUTRAL FIXTURE WIRE TO THE NEUTRAL JUNCTION BOX WIRE (USUALLY WHITE). FASTEN EACH TOGETHER WITH A WIRE CONNECTOR (K) AND WRAP THE CONNECTION WITH ELECTRICAL TAPE. BE SURE NO STRANDS ARE EXPOSED.
10. CONNECT THE HOT FIXTURE WIRE TO THE HOT JUNCTION BOX WIRE (USUALLY BLACK). FASTEN EACH TOGETHER WITH A PLASTIC WIRE CONNECTOR (K) AND WRAP THE CONNECTION WITH ELECTRICAL TAPE. BE SURE NO WIRE STRANDS ARE EXPOSED. **DO NOT REVERSE THE HOT AND NEUTRAL CONNECTIONS OR SAFETY WILL BE COMPROMISED.**
11. GENTLY TUCK THE WIRE CONNECTIONS NEATLY INTO THE JUNCTION BOX.
12. ATTACH THE MOUNTING PLATE (A) TO THE OUTLET BOX BY USING THE MOUNTING SCREWS(J) AND TIGHTEN SCREWS WITH A SCREWDRIVER.
13. ATTACH THE LAMP BODY(B) TO THE MOUNTING PLATE(A) BY USING THE ENCLOSED SET SCREWS(C) AND SECURE THE LAMP BODY(B) BY TIGHTENING 2 SET SCREWS(C) IN A CLOCKWISE DIRECTION.
14. RESTORE POWER TO THE JUNCTION BOX AND TEST FIXTURE.

CARE & MAINTENANCE

DUST WITH A DRY CLOTH.

FOR CUSTOMER SERVICE QUESTIONS CALL 1.888.488.8866

ARTERIOS HOME: 972.488.9800

ARTERIOS CONTRACT: 972.488.9800 EXT.321

DISCLAIMERS

WE RECOMMEND THE INSTALLATION OF THIS ELECTRICAL LIGHT FIXTURE TO BE DONE BY A LICENSED ELECTRICIAN.

ARTERIOS