

ASSEMBLY INSTRUCTIONS

ITEM #DJ49005 | LED FLUSH MOUNT

ITEM DESCRIPTION

MATERIAL TYPE: STEEL, GLASS FINISH : ENGLISH BRONZE + CAST GLASS TOP COAT/SEALANT:
SOCKET TYPE: LED SOCKET QTY: 1PC
BULB TYPE: LED BULB WATTAGE: LED 8W / 3000K / 90+CRI VOLTAGE: 100V-240V
ITEM NET WEIGHT:
CE & SAA COMPLIANT
INSTALLATION ENVIRONMENT: SUITABLE FOR DAMP LOCATIONS



NOTE:
*YOUR PRODUCT(S) MAY BE PACKED IN MORE THAN ONE CARTON

PARTS

A	MOUNTING PLATE	1 PC
B	INNER METAL FRAME	1 PC
C	THUMB-SCREW	6 PCS
D	OUTER METAL FRAME	1 PC

INCLUDED ASSEMBLY HARDWARE

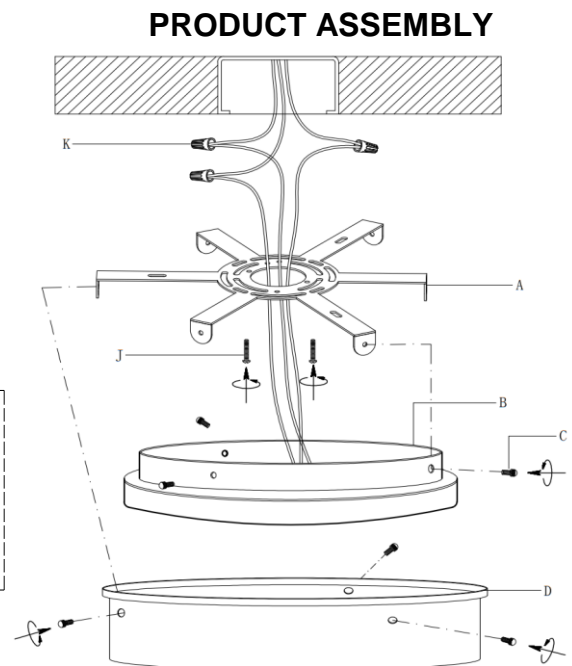
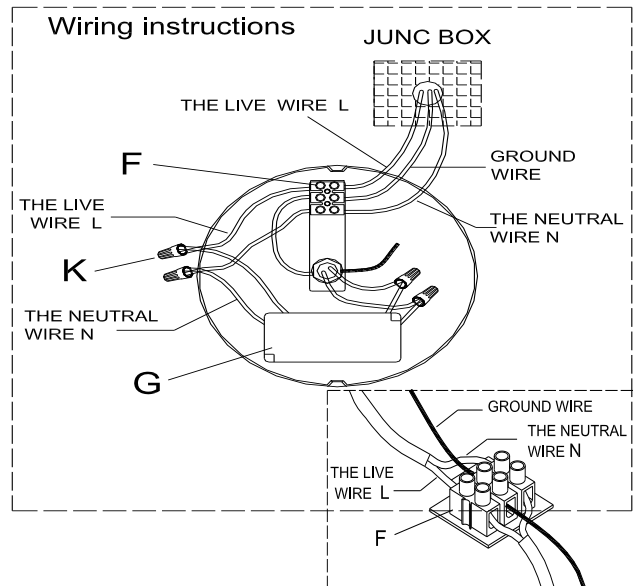
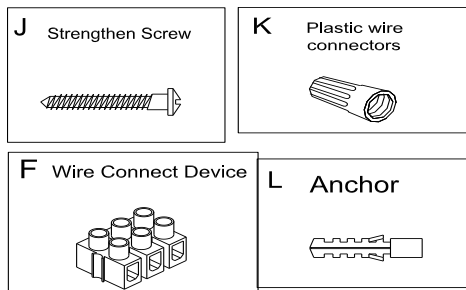

ASSEMBLY INSTRUCTIONS

1. REMOVE ALL PACKING CONTENTS AND PARTS FROM THE CARTON(S) CAREFULLY
2. PLEASE BE SURE YOU HAVE ALL PARTS INDICATED BEFORE YOU BEGIN ASSEMBLY
3. SHUT OFF THE MAIN ELECTRICAL SUPPLY FROM THE MAIN FUSE BOX/CIRCUIT BREAKER.
4. REMOVE THE MOUNTING PLATE (A) FROM THE INNER METAL FRAME (B) AND OUTER METAL FRAME (D) BY TURNING THUMB-SCREW (C) IN A COUNTER CLOCKWISE DIRECTION.
5. GENTLY PULL THE ELECTRICAL CORD FROM JUNCTION BOX, THEN PULL THE ELECTRICAL CORD FROM THROUGH THE EXIT HOLE OF THE MOUNTING PLATE (A).
6. DRILL HOLES AND INSERT THE ANCHOR (L) TO THE WALL FIRST, ALIGN THE HOLES AND ATTACHED MOUNTING PLATE (A) TO THE WALL THEN FASTEN IT WITH **STRENGTHEN SCREW (J)**.
7. CAREFULLY INSPECT THE SCENCE'S FIXTURE WIRES. THE NEUTRAL FIXTURE WIRE IS WHITE COLOR (LABELLED "N"), AND THE LIVE FIXTURE WIRE IS BLACK COLOR (LABELLED "L"). THE GREEN WIRE IS THE GROUNDED WIRE.
8. ATTACH THE GROUND WIRE FROM THE FIXTURE TO THE GROUND JUNCTION BOX WIRE FROM THE OUTLET (USUALLY GREEN OR BARE WIRE). PLS USE WIRE CONNECT DEVICE (F) TO CONNECT THEM IN THE CENTER PHASE.
IT IS IMPERATIVE THAT THE OUTLET BOX IN YOUR HOME BE PROPERLY GROUNDED.
BE SURE NO STRANDS ARE EXPOSED. IT IS IMPERATIVE THAT THE OUTLET BOX IN YOUR HOME BE PROPERLY GROUNDED.
9. USE WIRE CONNECT DEVICE (F) TO CONNECT THE NEUTRAL FIXTURE WIRE TO THE NEUTRAL JUNCTION BOX WIRE (USUALLY IS BLUE COLOR). LOOSE THE SCREWS ON THE WIRE CONNECT DEVICE (F) WITH A SCREWDRIVER FIRST, THEN INSERT THE NEUTRAL WIRE INTO THE WIRE CONNECT DEVICE (F) AND THEN TIGHTEN SCREWS WITH A SCREWDRIVER. **BE SURE NO STRANDS ARE EXPOSED.**
10. USE WIRE CONNECT DEVICE (F) TO CONNECT THE HOT FIXTURE WIRE TO THE HOT JUNCTION BOX WIRE (USUALLY IS BROWN COLOR). LOOSE THE SCREWS ON THE WIRE CONNECT DEVICE (F) WITH A SCREWDRIVER FIRST, THEN INSERT THE HOT WIRE INTO THE WIRE CONNECT DEVICE (F) AND THEN TIGHTEN SCREWS WITH A SCREWDRIVER.
BE SURE NO STRANDS ARE EXPOSED.
DO NOT REVERSE THE HOT AND NEUTRAL CONNECTIONS OR SAFETY WILL BE COMPROMISED.
DO NOT MIX UP THE DRIVER (G) INPUT AND OUTPUT OF THE CORDS
PLS REFER TO NEXT PAGE OF "WIRE CONNECTIONS FIG" FOR MORE DETAILS.
11. ATTACH THE INNER METAL FRAME (B) TO THE MOUNTING PLATE (A) BY USING THE ENCLOSED THUMB-SCREW (C) AND SECURE THE INNER METAL FRAME (B) BY TIGHTENING 3 SETS OF THUMB-SCREW (C) IN A CLOCKWISE DIRECTION.
12. ATTACH THE OUTER METAL FRAME (D) TO THE MOUNTING PLATE (A) BY USING THE ENCLOSED THUMB-SCREW (C) AND SECURE THE OUTER METAL FRAME (D) BY TIGHTENING 3 SETS OF THUMB-SCREW (C) IN A CLOCKWISE DIRECTION.
13. RESTORE POWER TO THE JUNCTION BOX AND TEST FIXTURE.
14. FOR NON-USER REPLACEABLE LIGHT SOURCES: THE LIGHT SOURCE CONTAINED IN THIS LUMINAIRE SHALL ONLY BE REPLACE BY THE MANUFACTURER OR HIS SERVICE AGENT OR A SIMILAR QUALIFIED PERSON.

CARE & MAINTENANCE

DUST WITH A DRY CLOTH.

DISCLAIMERS

FOR CUSTOMER SERVICE QUESTIONS CALL 1.888.488.886 WE RECOMMEND THE INSTALLATION OF THIS ELECTRICAL LIGHT FIXTURE TO BE DONE BY A LICENSED ELECTRICIAN.
ARTERIOS HOME: 972.488.9800
ARTERIOS CONTRACT: 972.488.9800 EXT.321

ARTERIOS