

ASSEMBLY INSTRUCTIONS

ITEM # DJ49001/ECKART SCONCE

ITEM DESCRIPTION

MATERIAL TYPE: IRON+SOLID CLEAR GLASS FINISH: ANTIQUE BRASS TOP COAT/SEALANT

SOCKET TYPE: E26

SOCKET QTY: 1PC

BULB TYPE: TYPE A

BULB WATTAGE: 60W OR/CFL 12W OR/LED 10W

VOLTAGE: 110V-120V

ITEM NET WEIGHT:

UL COMPLIANT

INSTALLATION ENVIRONMENT: SUITABLE FOR DAMP LOCATIONS



NOTE:

*YOUR PRODUCT(S) MAY BE PACKED IN MORE THAN ONE CARTON
*THIS ITEM MAY REQUIRE PERIODIC TIGHTENING

PARTS

A	MOUNTING PLATE	1 PC
B	BACK PLATE	1 PC
C	SOLID GLASS ROD	1 PC
D	SCREW	2 PCS
E	SOCKET	1 PC
F	LAMP BODY	1 PC
G	SHADE	1PC
H	SOCKET RING	1 PC

PRODUCT ASSEMBLY

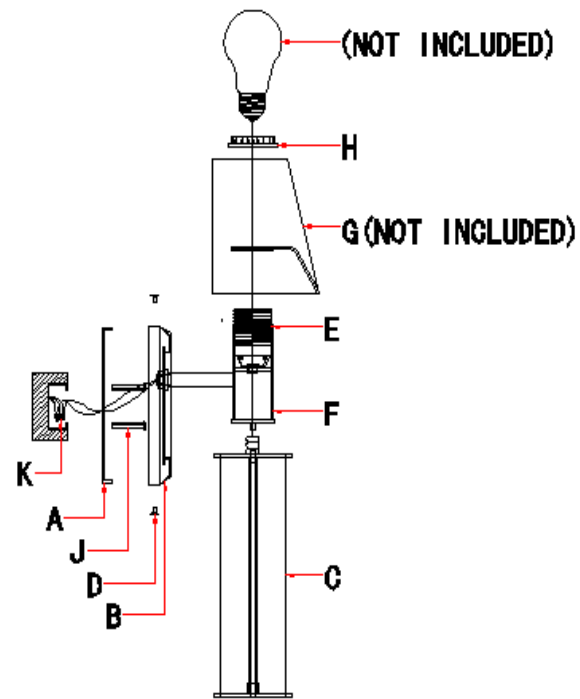

INCLUDED ASSEMBLY HARDWARE

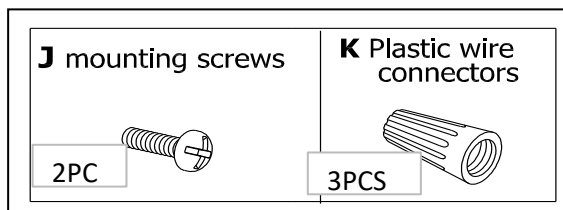

ASSEMBLY INSTRUCTIONS

1. REMOVE ALL PACKING CONTENTS AND PARTS FROM THE CARTON(S) CAREFULLY.
2. PLEASE BE SURE YOU HAVE ALL PARTS INDICATED BEFORE YOU BEGIN ASSEMBLY.
3. SHUT OFF THE MAIN ELECTRICAL SUPPLY FROM THE MAIN FUSE BOX/CIRCUIT BREAKER.
4. PULL THE ELECTRICAL CORD OF "J BOX" THROUGH THE EXIT HOLE OF THE MOUNTING PLATE (A)
5. ATTACH THE GROUND WIRE FROM THE FIXTURE TO THE GROUND JUNCTION BOX WIRE FROM THE OUTLET (USUALLY GREEN OR BARE WIRE). FASTEN EACH TOGETHER WITH A PLASTIC WIRE CONNECTOR (K) AND WRAP THE CONNECTION WITH ELECTRICAL TAPE. IF YOUR OUTLET BOX DOES NOT HAVE A GROUND WIRE, INSERT THE GREEN GROUND SCREW INTO THE MOUNTING PLATE (A) FACING DOWN, AND WRAP THE FIXTURE'S BARE GROUND WIRE AROUND THE GROUND SCREW. **IT IS IMPERATIVE THAT THE OUTLET BOX IN YOUR HOME BE PROPERLY GROUNDED.**
6. CONNECT THE NEUTRAL FIXTURE WIRE TO THE NEUTRAL JUNCTION BOX WIRE (USUALLY WHITE). FASTEN EACH TOGETHER WITH A WIRE CONNECTOR (K) AND WRAP THE CONNECTION WITH ELECTRICAL TAPE. BE SURE NO STRANDS ARE EXPOSED.
7. CONNECT THE HOT FIXTURE WIRE TO THE HOT JUNCTION BOX WIRE (USUALLY BLACK). FASTEN EACH TOGETHER WITH A PLASTIC WIRE CONNECTOR (K) AND WRAP THE CONNECTION WITH ELECTRICAL TAPE. BE SURE NO WIRE STRANDS ARE EXPOSED. **DO NOT REVERSE THE HOT AND NEUTRAL CONNECTIONS OR SAFETY WILL BE COMPROMISED.**
8. GENTLY TUCK THE WIRE CONNECTIONS NEATLY INTO THE JUNCTION BOX.
9. ATTACH THE MOUNTING PLATE (A) TO THE OUTLET BOX BY USING THE MOUNTING SCREW (J), AND TIGHTEN IT WITH A SCREWDRIVER.
10. ATTACH THE BACK PLATE (B) ONTO THE MOUNTING PLATE (A) WITH 2PCS SCREWS (D), AND TIGHTEN IT WITH A SCREWDRIVER.
11. TURN THE SOLID GLASS ROD (C) CLOCKWISE ON THE LAMP BODY (F).
12. REMOVE THE SOCKET RING (H) FROM THE SOCKET (E)
13. ATTACH THE SHADE (G) ON THE SOCKET (E) AND FASTEN IT WITH THE SOCKET RING (H).
14. INSERT ONE TYPE A 60W BULB (OR /CFL12W OR /LED10W, NOT INCLUDED) INTO THE SOCKET (E), DO NOT EXCEED THE SPECIFIED WATTAGE.
15. RESTORE POWER TO THE JUNCTION BOX AND TEST FIXTURE.

CARE & MAINTENANCE

DUST WITH A DRY CLOTH.

FOR CUSTOMER SERVICE QUESTIONS CALL 1.888.488.8866

DISCLAIMERS

WE RECOMMEND THE INSTALLATION OF THIS ELECTRICAL LIGHT FIXTURE TO BE DONE BY A LICENSED ELECTRICIAN.

ARTERIOS HOME:972.488.9800

ARTERIOS CONTRACT:972.488.9800 EXT.321

ARTERIOS

