

# ASSEMBLY INSTRUCTIONS

ITEM #89476 |Hozier Oval Chandelier

## ITEM DESCRIPTION

MATERIAL TYPE: STEEL FINISH :ANTIQUE BRASS.OIL RUBBER BRONZE  
 SOCKET TYPE: E12 CERAMIC SOCKET QTY:10 TOP COAT/SEALANT:  
 BULB TYPE: TYPE B BULB WATTAGE: 40W or/CFL 10W or/LED 9W  
 ITEM NET WEIGHT: TOP COAT/SEALANT:

UL COMPLAINT

INSTALLATION ENVIRONMENT:SUITABLE FOR DAMP LOCATIONS

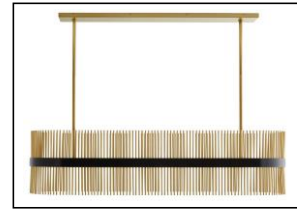





## NOTE:

\*YOUR PRODUCT(S) MAY BE PACKED IN MORE THAN ONE CARTON  
 \*THIS ITEM MAY REQUIRE PERIODIC TIGHTENING

## PARTS

<b>A</b>	<b>MOUNTING PLATE</b>	<b>1 PC</b>
<b>B</b>	<b>CANOPY</b>	<b>1 PC</b>
<b>C</b>	<b>RODS</b>	<b>8 PCS</b>
<b>D</b>	<b>MAIN BODY</b>	<b>1 PC</b>
<b>E</b>	<b>SET RING</b>	<b>2 PCS</b>
<b>F</b>	<b>WASHER</b>	<b>2 PCS</b>
<b>G</b>	<b>CANOPY SCREW</b>	<b>8 PCS</b>
<b>H</b>	<b>STEEL CABLE</b>	<b>1 PC</b>
<b>I</b>	<b>LOCK</b>	<b>1 PC</b>

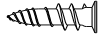
## INCLUDED ASSEMBLY HARDWARE

<b>J</b> Plastic wire connectors 	<b>K</b> mounting screws 	<b>L</b> allen wrench 
<b>M</b> anchor 	<b>N</b> strengthened screw 	

## PRODUCT ASSEMBLY

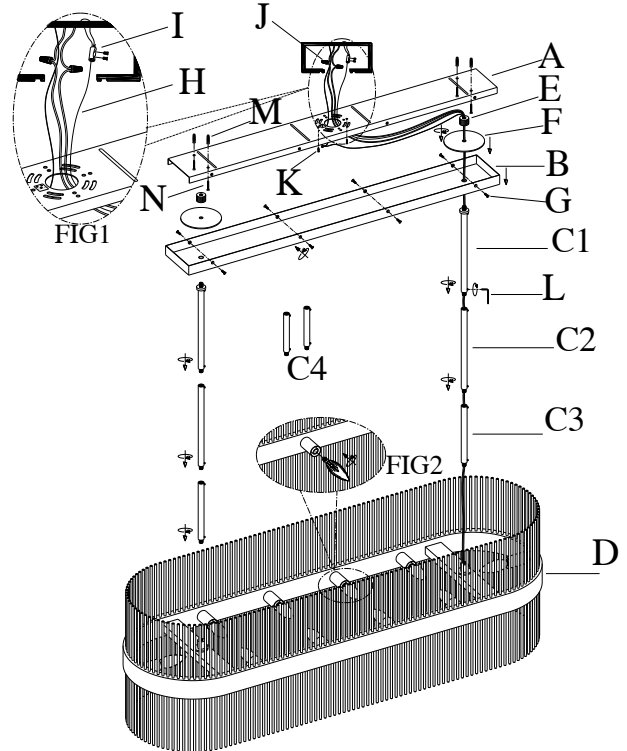

## ASSEMBLY INSTRUCTIONS

- REMOVE ALL PACKING CONTENTS FROM THE CARTON(S) CAREFULLY.
- REMOVE ALL PARTS FROM THE PACKAGE(S) CAREFULLY.
- PLEASE BE SURE YOU HAVE ALL PARTS INDICATED BEFORE YOU BEGIN ASSEMBLY.
- SHUT OFF THE MAIN ELECTRICAL SUPPLY FROM THE MAIN FUSE BOX/CIRCUIT BREAKER.
- REMOVE THE MOUNTING PLATE(A) FROM THE CANOPY(B) BY LOOSE 8PCS CANOPY SCREWS(G).
- SCREW THE ROD(C3) TO THE MAIN BODY(D), AND TIGHTEN THE HEXANGULAR SCREW IN THE SIDE DESIRE HOLE BY ALLEN WRENCH(L). REPEAT THE SAME OPERATION ON THE ROD (C1) AND (C2). IF THE CEILING IS HIGH ENOUGH , PLS ASSEMBLE THE ROD(C4) IF NEED.
- PASS THE ROD(C1) THROUGH CANOPY(B) ,AND TIGHTEN IT BY USING WASHER(F) AND SET RING(E).BE SURE PASS THROUGH THE CORD AS DRAWING SHOW. REPEAT THE ABOVE OPERATIONS(6) AND (7) ON ANOTHER SIDE.
- ATTACH STEEL CABLE(H) TO THE FIXED FIXTURE(AN APPROPRIATE LOAD BEARING STRUCTURE)ON THE CEILING WITH THE LOCK(I)  
**THIS LUMINAIRE MUST BE MOUNTED OR SUPPORTED INDEPENDENTLY OF AN OUTLEX BOX.**
- CAREFULLY INSPECT THE PENDANT'S FIXTURE WIRES. THE NEUTRAL FIXTURE WIRE HAS VERY FINE RIDEGS MOLDED INTO ITS PLASTIC COVERING. THE HOT FIXTURE WIRE HAS A SMOOTH COVERING.THE BARE SILVER WIRE IS THE GROUNDED WIRE.
- ATTACH THE GROUND WIRE FROM THE FIXTURE TO THE GROUND JUNCTION BOX WIRE FROM THE OUTLET (USUALLY GREEN) OR BARE WIRE). FASTEN EACH TOGETHER WITH A PLASTIC WIRE CONNECTOR (J) AND WRAP THE CONNECTION WITH ELECTRICAL TAPE. IF YOUR OUTLET BOX DOES NOT HAVE A GROUND WIRE, INSERT THE GREEN GROUND SCREW INTO THE MOUNTING PLATE (A) FACING DOWN, AND WRAP THE FIXTURE'S BARE GROUND WIRE AROUND THE GROUND SCREW. IT IS IMPERATIVE THAT THE OUTLET BOX IN YOUR HOME BE PROPERLY GROUNDED.
- CONNECT THE NEUTRAL FIXTURE WIRE TO THE NEUTRAL JUNCTION BOX WIRE (USUALLY WHITE). FASTEN EACH TOGETHER WITH A WIRE CONNECTOR (J) AND WRAP THE CONNECTION WITH ELECTRICAL TAPE. BE SURE NO STRANDS ARE EXPOSED.
- CONNECT THE HOT FIXTURE WIRE TO THE HOT JUNCTION BOX WIRE (USUALLY BLACK). FASTEN EACH TOGETHER WITH A PLASTIC WIRE CONNECTOR (J) AND WRAP THE CONNECTION WITH ELECTRICAL TAPE. BE SURE NO WIRE STRANDS ARE EXPOSED. DO NOT REVERSE THE HOT AND NEUTRAL CONNECTIONS OR SAFETY WILL BE COMPROMISED.
- GENTLY TRUCK THE WIRE CONNECTIONS NEATLY INTO THE CEILING JUNCTION BOX.
- ATTACH THE MOUNTING PLATE (A) WITH NIPPLE TO THE CEILING OUTLET BOX USING THE ENCLOSED MOUNTING SCREWS (K) AND TIGHTEN SCREWS WITH A SCREWDRIVER.
- IF ATTACH TO CEMENT CEILING, USE ANCHOR(M) FIRST THEN SCREW STRENGTHENED SCREWS(N) INTO THE ANCHOR.
- IF ATTACH TO WOOD CEILING, THREAD STRENGTHENED SCREW(N) DIRECTLY INTO CEILING.
- PUSH MOUNTING PLATE(A) IN CANOPY (B) AND THREAD THE CANOPY SCREWS(G) TO SECURE IT TILL TIGHT.
- INSERT 10 TYPE B 40W BULBS(OR SUITABLE CFL/10W,OR LED 9W BULBS, NOT INCLUDED)S INTO THE SOCKETS AS FIG2. **DO NOT EXCEED SPECIFIED WATTAGE.**  
**BE SURE ALL THE HEXANGULAR SCREWS ARE TIGHT ENOUGH.**

## CARE & MAINTENANCE

FOR CUSTOMER SERVICE QUESTION CALL 1-800-338-2150  
 ARTERIORS HOME:972.488.9800  
 ARTERIORS CONTRACT:972.488.9800 EXT.321

## DISCLAIMERS

WE RECOMMEND THE INSTALLATION OF THIS ELECTRICAL LIGHT FIXTURE TO BE DONE BY A LICENSED ELECTRICIAN.

# ARTERIORS