

ARTERIOS

MANCHESTER PENDANT

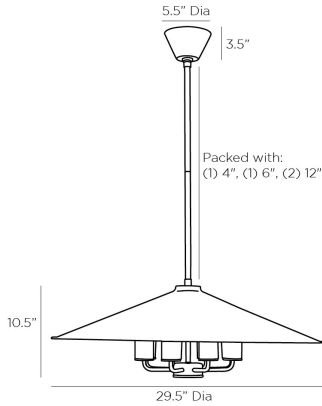

49790
H: 19.5 IN, Dia: 29.50 IN
English Bronze
Contract Suitable As Is

The Manchester takes inspiration from traditional pendant design and modernizes it with rich materials. An English bronze steel foundation is matched with an antique brass-plated interior for a stark but stylish contrast. The slim but wide shade exposes eight lights, each encased by a white alabaster sleeve for a more elevated look. Additional pipe available (PIPE-487). Damp-rated, although limited covered outdoor areas may affect finish.

APPEARANCE

Material	English Bronze
Material Type	Alabaster, Steel
Finish	Plated
Top Coat/Sealant	Antique Brass, English Bronze, White
	true

DIMENSIONS

Pendant	H: 10.5 IN, Dia: 29.50 IN
Minimum Hanging Height	19.5 IN
Maximum Hanging Height	49.5 IN
Canopy	H: 3.5 IN, Dia: 5.50 IN

WIRING

Rating	UL,EU,SA
Cord	Damp
Socket	10 FT, Black/White, SVT
Photographed Bulb	8, Type B - E12
Maximum Watt	2" Frosted Globe Bulb
Voltage	40
	110-120 V

CERTIFICATIONS

Certifications	Mexico
	Australia, European Union, United Arab Emirates, United States, Canada

COMPLIANCY

UL/ETL	Yes
CB	Yes
RoHS	true

SHIPPING

Product Weight	15 LBS
Gross Weight 1	28 LBS
Shipping Box 1	H: 13.5 IN, L: 32 IN, W: 32 IN
Shipping Box 3	H: 0

REPLACEMENT PARTS

Replacement Part 1	PIPE-487
Replacement Part 1 Dim	(1) 4", (1) 6", (1) 12"
Replacement Part 2	CANOPY-597
Replacement Part 2 Dim	3" x 5.5"

CONTRACT

Contract Suitable	true
-------------------	------