

ASSEMBLY INSTRUCTIONS

ITEM #49785 | METAL SPIKES FLUSH MOUNT

ITEM DESCRIPTION

MATERIAL TYPE: STEEL FINISH :ANTIQUE BRASS TOP COAT/SEALANT:
SOCKET TYPE: E27 CERAMIC SOCKET QTY: 1PC
BULB TYPE: TYPE A BULB WATTAGE: **60W or /CFL 13W or LED 8W** VOLTAGE: 220-240V
ITEM NET WEIGHT:
UL COMPLIANT
INSTALLATION ENVIRONMENT:SUITABLE FOR DAMP LOCATIONS



NOTE:

*YOUR PRODUCT(S) MAY BE PACKED IN MORE THAN ONE CARTON
*THIS ITEM MAY REQUIRE PERIODIC TIGHTENING

PARTS

A	MOUNTING PLATE	1 PC
B	LAMP BODY	1 PC
C	SET SCREW	2 PCS
D	BULB(NOT INCLUDED)	1PC

INCLUDED ASSEMBLY HARDWARE

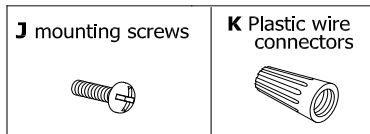

PRODUCT ASSEMBLY

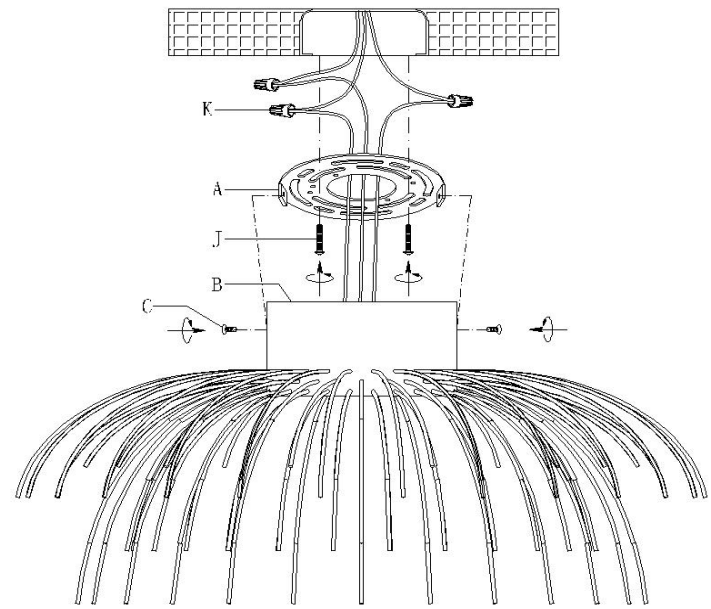

ASSEMBLY INSTRUCTIONS

- 1.REMOVE ALL PACKING CONTENTS AND PARTS FROM THE CARTON(S)CAREFULLY.
- 2.PLEASE BE SURE YOU HAVE ALL PARTS INDICATED BEFORE YOU BEGIN ASSEMBLY.
- 3.SHUT OFF THE MAIN ELECTRICAL SUPPLY FROM THE MAIN FUSE BOX/CIRCUIT BREAKER.
- 4.REMOVE THE MOUNTING PLATE (A) FROM THE LAMP BODY(B) BY TURNING SET SCREW(C) IN A ANTICLOCKWISE DIRECTION.
- 5.CAREFULLY INSPECT THE FIXTURE WIRES. THE NEUTRAL FIXTURE WIRE HAS VERY FINE RIDEGS MOLDED INTO ITS PLASTIC COVERING. THE HOT FIXTURE WIRE HAS A SMOOTH COVERING.THE BARE WIRE IS THE GROUNDED WIRE.
- 6.ATTACH THE GROUND WIRE FROM THE FIXTURE TO THE GROUND JUNCTION BOX WIRE FROM THE OUTLET (USUALLY GREEN OR BARE WIRE). FASTEN EACH TOGETHER WITH A PLASTIC WIRE CONNECTOR (K) AND WRAP THE CONNECTION WITH ELECTRICAL TAPE. IF YOUR OUTLET BOX DOES NOT HAVE A GROUND WIRE, INSERT THE GREEN GROUND SCREW INTO THE MOUNTING PLATE (A) FACING DOWN, AND WRAP THE FIXTURE'S BARE GROUND WIRE AROUND THE GROUND SCREW. **IT IS IMPERATIVE THAT THE OUTLET BOX IN YOUR HOME BE PROPERLY GROUNDED.**
- 7.CONNECT THE NEUTRAL FIXTURE WIRE TO THE NEUTRAL JUNCTION BOX WIRE (USUALLY WHITE). FASTEN EACH TOGETHER WITH A WIRE CONNECTOR (K) AND WRAP THE CONNECTION WITH ELECTRICAL TAPE. BE SURE NO STRANDS ARE EXPOSED.
- 8.CONNECT THE HOT FIXTURE WIRE TO THE HOT JUNCTION BOX WIRE (USUALLY BLACK). FASTEN EACH TOGETHER WITH A PLASTIC WIRE CONNECTOR (K) AND WRAP THE CONNECTION WITH ELECTRICAL TAPE. BE SURE NO WIRE STRANDS ARE EXPOSED. **DO NOT REVERSE THE HOT AND NEUTRAL CONNECTIONS OR SAFETY WILL BE COMPROMISED.**
- 9.GENTLY TUCK THE WIRE CONNECTIONS(K) NEATLY INTO THE CEILING JUNCTION BOX.
- 10.ATTACH THE MOUNTING PLATE (A) TO THE OUTLET BOX USING THE MOUNTING SCREWS(J) AND TIGHTEN SCREWS(J) WITH A SCREWDRIVER.
- 11.ATTACH THE LAMP BODY(B) TO THE MOUNTING PLATE(A) BY USING THE ENCLOSED 2PCS OF SET SCREWS(C) AND TIGHTEN SCREWS WITH A SCREWDRIVER.
- 12.INSERT 1 PYPE A 60W or /CFL 13W or LED 8W BULB(NOT INCLUDED) INTO THE SOCKET .**DO NOT EXCEED SPECIFIED WATTAGE**
- 13.RESTORE POWER TO THE JUNCTION BOX AND TEST FIXTURE.

CARE & MAINTENANCE

DUST WITH A DRY CLOTH.

FOR CUSTOMER SERVICE QUESTIONS CALL 1.888.488.8866

ARTERIOR'S HOME:972.488.9800

ARTERIOR'S CONTRACT:972.488.9800 EXT.321

DISCLAIMERS

WE RECOMMEND THE INSTALLATION OF THIS ELECTRICAL LIGHT FIXTURE TO BE DONE BY A LICENSED ELECTRICIAN.

ARTERIOR'S