

ASSEMBLY INSTRUCTIONS

ITEM #89633 | CHANDELIER



ITEM DESCRIPTION

MATERIAL TYPE: STEEL FINISH : ANTIQUE BRASS TOP COAT/SEALANT:
 SOCKET TYPE: E12 CERAMIC SOCKET QTY:20
 BULB TYPE: TYPE G BULB WATTAGE: 25W or/CFL 7W or/LED 5W
 ITEM NET WEIGHT: TOP COAT/SEALANT:

UL COMPLAINT

INSTALLATION ENVIRONMENT: SUITABLE FOR DAMP LOCATIONS

NOTE:

*YOUR PRODUCT(S) MAY BE PACKED IN MORE THAN ONE CARTON
 *THIS ITEM MAY REQUIRE PERIODIC TIGHTENING

PARTS

A	MOUNTING PLATE	1 PC
B	CANOPY	1 PC
C	COLLAR LOOP	1 PC
D	RODS	3 PCS
E	MAIN BODY	1 PC

INCLUDED ASSEMBLY HARDWARE



PRODUCT ASSEMBLY

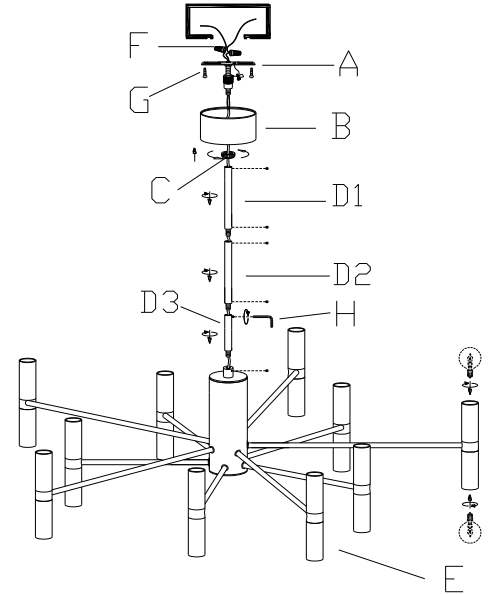

ASSEMBLY INSTRUCTIONS

1. REMOVE ALL PACKING CONTENTS FROM THE CARTON(S) CAREFULLY
2. REMOVE ALL PARTS FROM THE PACKAGE(S) CAREFULLY
3. PLEASE BE SURE YOU HAVE ALL PARTS INDICATED BEFORE YOU BEGIN ASSEMBLY
4. SHUT OFF THE MAIN ELECTRICAL SUPPLY FROM THE MAIN FUSE BOX/CIRCUIT BREAKER
5. REMOVE THE MOUNTING PLATE (A) FROM THE CANOPY (B) BY TURNING COLLAR LOOP (C) IN A COUNTER CLOCKWISE DIRECTION.
6. SCREW THE ROD (D3) TO THE TOP MAIN BODY (E), AND TIGHTEN THE HEXANGULAR SCREW IN THE SIDE DESIRE HOLE BY ALLEN WRENCH (H).
REPEAT THE SAME OPERATION ON THE ROD (D1) AND (D2).
7. CAREFULLY INSPECT THE PENDANT'S FIXTURE WIRES. THE NEUTRAL FIXTURE WIRE HAS VERY FINE RIDEGS MOLDED INTO ITS PLASTIC COVERING. THE HOT FIXTURE WIRE HAS A SMOOTH COVERING. THE BARE SILVER WIRE IS THE GROUNDED WIRE.
8. ATTACH THE GROUND WIRE FROM THE FIXTURE TO THE GROUND JUNCTION BOX WIRE FROM THE OUTLET (USUALLY GREEN) OR BARE WIRE). FASTEN EACH TOGETHER WITH A PLASTIC WIRE CONNECTOR (F) AND WRAP THE CONNECTION WITH ELECTRICAL TAPE. IF YOUR OUTLET BOX DOES NOT HAVE A GROUND WIRE, INSERT THE GREEN GROUND SCREW INTO THE MOUNTING PLATE (A) FACING DOWN, AND WRAP THE FIXTURE'S BARE GROUND WIRE AROUND THE GROUND SCREW. IT IS IMPERATIVE THAT THE OUTLET BOX IN YOUR HOME BE PROPERLY GROUNDED.
9. CONNECT THE NEUTRAL FIXTURE WIRE TO THE NEUTRAL JUNCTION BOX WIRE (USUALLY WHITE). FASTEN EACH TOGETHER WITH A WIRE CONNECTOR (F) AND WRAP THE CONNECTION WITH ELECTRICAL TAPE. BE SURE NO STRANDS ARE EXPOSED.
10. CONNECT THE HOT FIXTURE WIRE TO THE HOT JUNCTION BOX WIRE (USUALLY BLACK). FASTEN EACH TOGETHER WITH A PLASTIC WIRE CONNECTOR (F) AND WRAP THE CONNECTION WITH ELECTRICAL TAPE. BE SURE NO WIRE STRANDS ARE EXPOSED. DO NOT REVERSE THE HOT AND NEUTRAL CONNECTIONS OR SAFETY WILL BE COMPROMISED.
11. GENTLY TUCK THE WIRE CONNECTIONS NEATLY INTO THE CEILING JUNCTION BOX.
12. ATTACH THE MOUNTING PLATE (A) WITH NIPPLE TO THE CEILING OUTLET BOX USING THE ENCLOSED MOUNTING SCREWS (G) AND TIGHTEN SCREWS WITH A SCREWDRIVER.
13. PUSH COLLAR LOOP IN CANOPY (B) AND THREAD ONTO NIPPLE IN MOUNTING PLATE (A) BY TURNING IN A CLOCKWISE
14. SCREW ROD (D1) TO CANOPY (B), USING HEXANGULAR SCREW AND ALLEN WRENCH (H)
BE SURE ALL THE HEXANGULAR SCREWS ARE TIGHT ENOUGH.
15. INSERT 20 TYPE G 25W BULBS (OR SUITABLE /CFL 7W OR/LED 5W BULBS, NOT INCLUDED) IN THE SOCKETS.
DO NOT EXCEED SPECIFIED WATTAGE .

CARE & MAINTENANCE

FOR CUSTOMER SERVICE QUESTION CALL 1-800-338-2150

DISCLAIMERS

ARTERIOS HOME: 972.488.9800

WE RECOMMEND THE INSTALLATION OF THIS ELECTRICAL LIGHT FIXTURE TO BE DONE BY A LICENSED ELECTRICIAN.

ARTERIOS CONTRACT: 972.488.9800 EXT.321

ARTERIOS