

# ASSEMBLY INSTRUCTIONS

ITEM # 89350 | HANGING SMOKE GLS AND BROWN NICKEL OVAL CHANDELIER

## ITEM DESCRIPTION

MATERIAL TYPE: STEEL, GLASS FINISH : BROWN NICKEL, **SMOKE GLASS** TOP COAT/SEALANT:  
 SOCKET TYPE: E12 CERAMIC SOCKET QTY: 12  
 BULB TYPE: TYPE B BULB WATTAGE: 60W or/CFL 12W or/LED 10W VOLTAGE: 110V-120V  
 ITEM NET WEIGHT:



UL COMPLIANT

INSTALLATION ENVIRONMENT: SUITABLE FOR **DAMP** LOCATIONS

### NOTE:

- \*YOUR PRODUCT(S) MAY BE PACKED IN MORE THAN ONE CARTON
- \*THIS ITEM MAY REQUIRE PERIODIC TIGHTENING

## PARTS

<b>A</b>	MOUNTING PLATE	1 PC
<b>B</b>	CANOPY SCREWS	2 PCS
<b>C</b>	CANOPY	1 PC
<b>D</b>	METAL PLATE	1 PC
<b>E</b>	HEX NUT	2 PCS
<b>F</b>	LOCK WASHER	2 PCS
<b>G</b>	WASHER	2 PCS
<b>H</b>	WRENCH	1 PC
<b>I</b>	HOOK 1	2 PCS
<b>L</b>	HOOK 2	2 PCS
<b>M</b>	RODS	6 PCS
<b>N</b>	LAMP BODY	1 PC
<b>O</b>	<b>GLASS</b>	130 PCS
<b>P</b>	SOCKETS	12 PCS
<b>Q</b>	ANCHOR	2 PCS
<b>R</b>	STRENGTHEN SCREWS	2 PCS
<b>S</b>	BULBS (NOT INCLUDED)	12 PCS
<b>T</b>	<b>HEX SCREWS</b>	12 PCS
<b>U</b>	<b>ALLEN WRENCH</b>	1 PC

## PRODUCT ASSEMBLY

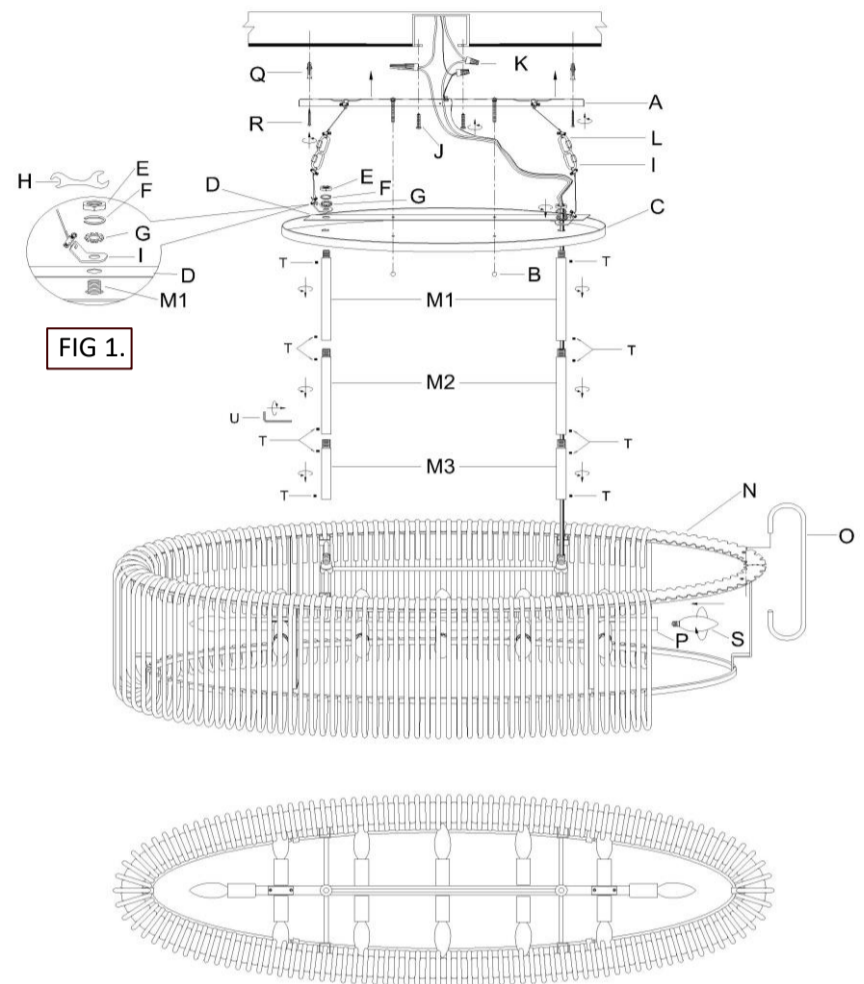

## INCLUDED ASSEMBLY HARDWARE

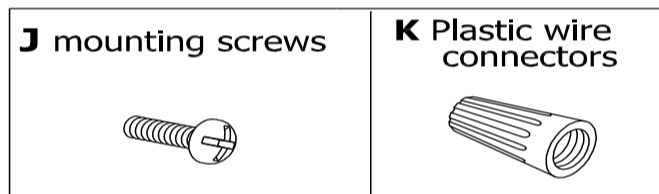

## ASSEMBLY INSTRUCTIONS

1. REMOVE ALL PACKING CONTENTS AND PARTS FROM THE CARTON(S) CAREFULLY
2. PLEASE BE SURE YOU HAVE ALL PARTS INDICATED BEFORE YOU BEGIN ASSEMBLY
3. SHUT OFF THE MAIN ELECTRICAL SUPPLY FROM THE MAIN FUSE BOX/CIRCUIT BREAKER.
4. CONNECT LAMP BODY(N) AND CANOPY(C) WITH RODS(M1, M2, M3) **WHEN YOU CONNECT THE RODS, LOOSEN THE SMALL HEX SCREWS(T) FIRST THEN TIGHTEN WITH ALLEN WRENCH(U). AFTER ALL RODS ARE CONNECTED. BE SURE ALL THE HEXANGULAR SCREWS ARE TIGHT ENOUGH.**
5. PLACE THE METAL PLATE(D), HOOK 1(I), WASHER(G), LOCK WASHER(F), HEX NUT(E) ONTO THE CANOPY ( C ), THEN SECURE WITH WRENCH(H) AS **FIG 1. LOCK HOOK(I) AND HOOK(L) TOGETHER AND BE SURE LOCKED COMPLETED AND SAFETY.**
6. PULL THE ELECTRICAL CORD FROM CANOPY THROUGH THE EXIT HOLE OF THE MOUNTING PLATE(A)
7. DRILL 2 HOLES IN WALL IN LINE WITH 2 HOLES OF MOUNTING PLATE(A), INSERT ANCHORS(Q) INTO DRILLED HOLES. FASTEN MOUNTING PLATE(A) TO WALL BY SCREWING THE 2 STRENGTHEN SCREWS(R) PROVIDED IN THE ANCHORS(Q).
8. ATTACH THE MOUNTING PLATE (A) TO THE OUTLET BY BOX USING THE MOUNTING SCREWS(J).
9. CAREFULLY INSPECT THE PENDANT'S FIXTURE WIRES. THE NEUTRAL FIXTURE WIRE HAS VERY FINE RIDGES MOLDED INTO ITS PLASTIC COVERING. THE HOT FIXTURE WIRE HAS A SMOOTH COVERING. THE BARE SILVER WIRE IS THE GROUNDED WIRE
10. ATTACH THE GROUND WIRE FROM THE FIXTURE TO THE GROUND JUNCTION BOX WIRE FROM THE OUTLET (USUALLY GREEN OR BARE WIRE). FASTEN EACH TOGETHER WITH A PLASTIC WIRE CONNECTOR (I) AND WRAP THE CONNECTION WITH ELECTRICAL TAPE. IF YOUR OUTLET BOX DOES NOT HAVE A GROUND WIRE, INSERT THE GREEN GROUND SCREW(H) INTO THE MOUNTING PLATE (A) FACING DOWN, AND WRAP THE FIXTURE'S BARE GROUND WIRE AROUND THE GROUND SCREW. **IT IS IMPERATIVE THAT THE OUTLET BOX IN YOUR HOME BE PROPERLY GROUNDED.**
11. CONNECT THE NEUTRAL FIXTURE WIRE TO THE NEUTRAL JUNCTION BOX WIRE (USUALLY WHITE). FASTEN EACH TOGETHER WITH A WIRE CONNECTOR (I) AND WRAP THE CONNECTION WITH ELECTRICAL TAPE. BE SURE NO STRANDS ARE EXPOSED.
12. CONNECT THE HOT FIXTURE WIRE TO THE HOT JUNCTION BOX WIRE (USUALLY BLACK). FASTEN EACH TOGETHER WITH A PLASTIC WIRE CONNECTOR (I) AND WRAP THE CONNECTION WITH ELECTRICAL TAPE. BE SURE NO WIRE STRANDS ARE EXPOSED. **DO NOT REVERSE THE HOT AND NEUTRAL CONNECTIONS OR SAFETY WILL BE COMPROMISED.**
13. GENTLY TUCK THE WIRE CONNECTIONS NEATLY INTO THE CEILING JUNCTION BOX.
14. ATTACH THE CANOPY(C) TO THE MOUNTING PLATE(A) USING THE ENCLOSED CANOPY SCREWS(B). SECURE THE CANOPY BY TIGHTENING 2 CANOPY SCREWS(B)
15. INSERT 12 TYPE B 60W BULB (OR CFL 12W OR LED 10W, NOT INCLUDED)(P) INTO THE SOCKETS(P). **DO NOT EXCEED SPECIFIED WATTAGE**
16. ATTACH GLASS(O) ONTO LAMP BODY(N) CAREFULLY AND ADJUST THE GLASS (O) IN A COMFORTABLE SPACE
17. RESTORE POWER TO THE JUNCTION BOX AND TEST FIXTURE.

## CARE & MAINTENANCE

DUST WITH A DRY CLOTH.

FOR CUSTOMER SERVICE QUESTIONS CALL 1.888.488.8866

ARTERIOS HOME: 972.488.9800

ARTERIOS CONTRACT: 972.488.9800 EXT. 321

## DISCLAIMERS

WE RECOMMEND THE INSTALLATION OF THIS ELECTRICAL LIGHT FIXTURE TO BE DONE BY A LICENSED ELECTRICIAN.

# ARTERIOS