

ASSEMBLY INSTRUCTIONS

ITEM # DA49015 / DA49016 | Bend Sconce

ITEM DESCRIPTION

MATERIAL TYPE: STEEL, GLASS FINISH :BLACKENED METAL + AMBER OR SMOKE GLASS TOP COAT/SEALANT:
SOCKET TYPE: E12 CERAMIC SOCKET QTY: 2 PCS
BULB TYPE:TYPE T BULB WATTAGE: 60W or /CFL 13W or/LED 8W VOLTAGE:110V-120V
ITEM NET WEIGHT:
UL COMPLIANT
INSTALLATION ENVIRONMENT: SUITABLE FOR DAMP LOCATIONS



NOTE:
*YOUR PRODUCT(S) MAY BE PACKED IN MORE THAN ONE CARTON

PARTS

A	MOUNTING PLATE	1 PC
B	CANOPY SCREW	4 PCS
C	LAMP BODY	1 PC
D	SOCKET	2 PCS
E	BULB (NOT INCLUDED)	2 PCS
F	GLASS	1 PC
G	THUMB-SCREW	4 PCS
I	ANCHOR	3 PCS
L	STRENGTHEN SCREW	3 PCS

INCLUDED ASSEMBLY HARDWARE

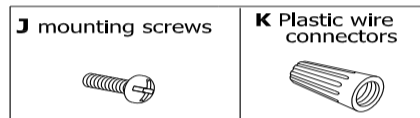

PRODUCT ASSEMBLY

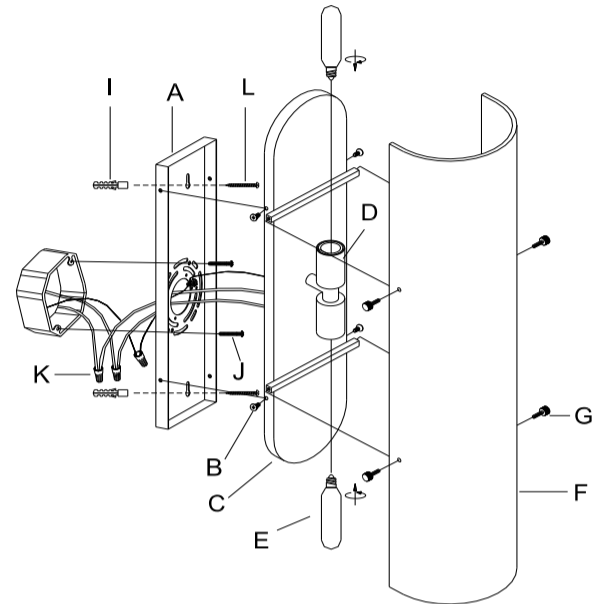

ASSEMBLY INSTRUCTIONS

- 1.REMOVE ALL PACKING CONTENTS AND PARTS FROM THE CARTON(S)CAREFULLY
- 2.PLEASE BE SURE YOU HAVE ALL PARTS INDICATED BEFORE YOU BEGIN ASSEMBLY
- 3.SHUT OFF THE MAIN ELECTRICAL SUPPLY FROM THE MAIN FUSE BOX/CIRCUIT BREAKER.
- 4.GENTLY PULL THE ELECTRICAL CORD FROM JUNCTION BOX, THEN PULL THE ELECTRICAL CORD FROM BACK PLATE THROUGH THE EXIT HOLE OF THE MOUNTING PLATE(A).
5. REMOVE THE MOUNTING PLATE (A) FROM THE LAMP BODY (C) BY LOOSE SCREWS(B)
6. POSITION FIXTURE IN DESIRED LOCATION ON WALL. THE MOUNTING PLATE(A) FEATURES (2) HOLES FOR SCREW MOUNTING. MARK THESE SPOTS ON THE WALL WITH A PENCIL TO DRILL HOLES.INSERT PLASTIC WALL ANCHORS (I) INTO DRILLED HOLES FOR FASTENING THE MOUNTING PLATE(A). PLACE THE MOUNTING PLATE(A) SO THAT HOLES ON THE MOUNTING PLATE(A) ARE ALIGNED WITH HOLES ON THE WALL AND FASTEN IT LOOSELY WITH STRENGTHEN SCREWS (L) TO CHECK THE ALIGNMENT.
- 7.CAREFULLY INSPECT THE FIXTURE WIRES. THE NEUTRAL FIXTURE WIRE HAS VERY FINE RIDEGS MOLDED INTO ITS PLASTIC COVERING. THE HOT FIXTURE WIRE HAS A SMOOTH COVERING.THE BARE WIRE IS THE GROUNDED WIRE.
8. ATTACH THE GROUND WIRE FROM THE FIXTURE TO THE GROUND JUNCTION BOX WIRE FROM THE OUTLET (USUALLY GREEN OR BARE WIRE). FASTEN EACH TOGETHER WITH A PLASTIC WIRE CONNECTOR (K) AND WRAP THE CONNECTION WITH ELECTRICAL TAPE. IF YOUR OUTLET BOX DOES NOT HAVE A GROUND WIRE, INSERT THE GREEN GROUND SCREW INTO THE MOUNTING PLATE (A) FACING DOWN, AND WRAP THE FIXTURE'S BARE GROUND WIRE AROUND THE GROUND SCREW.
IT IS IMPERATIVE THAT THE OUTLET BOX IN YOUR HOME BE PROPERLY GROUNDED.
9. CONNECT THE NEUTRAL FIXTURE WIRE TO THE NEUTRAL JUNCTION BOX WIRE (USUALLY WHITE). FASTEN EACH TOGETHER WITH A WIRE CONNECTOR (K) AND WRAP THE.CONNECTION WITH ELECTRICAL TAPE. BE SURE NO STRANDS ARE EXPOSED.
- 10.CONNECT THE HOT FIXTURE WIRE TO THE HOT JUNCTION BOX WIRE (USUALLY BLACK). FASTEN EACH TOGETHER WITH A PLASTIC WIRE CONNECTOR (K) AND WRAP THE CONNECTION WITH ELECTRICAL TAPE. BE SURE NO WIRE STRANDS ARE EXPOSED. **DO NOT REVERSE THE HOT AND NEUTRAL CONNECTIONS OR SAFETY WILL BE COMPROMISED.**
11. GENTLY TUCK THE WIRE CONNECTIONS NEATLY INTO THE JUNCTION BOX.
- 12.ATTACH THE MOUNTING PLATE (A) TO THE OUTLET BOX BY USING THE MOUNTING SCREWS(J)AND TIGHTEN SCREWS WITH A SCREWDRIVER.
- 13.ATTACH THE LAMP BODY(C) TO THE MOUNTING PLATE(A) BY USING THE ENCLOSED CANOPY SCREWS(B) AND TIGHTEN SCREWS WITH A SCREWDRIVER.
- 14.INSERT 2 TYPE T 60W BULBS or/CFL 13W or/LED 8W (NOT INCLUDED) INTO THE SOCKETS(D).
- 15.AFFIX THE GLASS (F) ONTO THE LAMP BODY (C),AND SECURE GLASS WITH 4PCS OF THE THUMB-SCREWS(G).**DO NOT OVERTIGHTEN GLASS.**
- 16.RESTORE POWER TO THE JUNCTION BOX AND TEST FIXTURE.

CARE & MAINTENANCE

DUST WITH A DRY CLOTH.

FOR CUSTOMER SERVICE QUESTIONS CALL 1.888.488.8866
ARTERIOS HOME:972.488.9800
ARTERIOS CONTRACT:972.488.9800 EXT.321

DISCLAIMERS

WE RECOMMEND THE INSTALLATION OF THIS ELECTRICAL LIGHT FIXTURE TO BE DONE BY A LICENSED ELECTRICIAN.

ARTERIOS