

ARTERIOS

HARVEY PENDANT

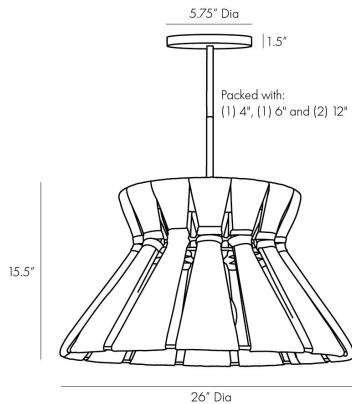

45627

H: 19 IN, Dia: 26.00 IN

Natural and Black Stained Rattan, Ant
ique Brass

Contract Suitable As Is

The Harvey pendant's design is quite rare. Natural rattan is first steamed and then wrapped by hand onto a steel frame in a wheat sheaf fashion then cinched in a ponytail style with black rattan. An unrivaled design and use of mixed materials deliver captivating visual appeal. An antique brass pipe showcases the unique shade and delivers a contrasting element that elevates its natural aesthetic. Finish will vary. Additional pipe available (PIPE-504). Damp rated, though limited outdoor conditions may affect finish. Damp-rated, although limited covered outdoor areas may affect finish.

APPEARANCE

Material	Rattan, Steel
Finish	Antique Brass, Black, Natural
Finish Will Vary	true
Top Coat/Sealant	true

DIMENSIONS

Pendant	H: 19 IN, Dia: 26.00 IN
Minimum Hanging Height	19 IN
Maximum Hanging Height	47 IN
Canopy	H: 1.5 IN, Dia: 5.75 IN

WIRING

	UL,EU,SA
Rating	Damp
Cord	10 FT, Clear/Silver, SVT
Socket	1, Type A - E26
Maximum Watt	100
Voltage	110-120 V

CERTIFICATIONS

	Mexico
Certifications	Australia, European Union, United Arab Emirates, United States, Canada

COMPLIANCY

UL/ETL	Yes
CB	Yes
RoHS	true

SHIPPING

Product Weight	9.92 LBS
Gross Weight 1	12.13 LBS
Gross Weight 2	12 LBS
Shipping Box 1	H: 27 IN, L: 27 IN, W: 17.5 IN
Shipping Box 2	H: 5 IN, L: 5 IN, W: 12 IN

ADDITIONAL INFO

Features	Sustainable
----------	-------------

REPLACEMENT PARTS

Replacement Part 1	PIPE-504
Replacement Part 1 Dim	(1) 4", (1) 6", (1) 12"
Replacement Part 2	CANOPY-654
Replacement Part 2 Dim	5.75" x 1"

CONTRACT

Contract Suitable	true
-------------------	------