

ASSEMBLY INSTRUCTIONS

ITEM #49006| Stefan Wall Sconce

ITEM DESCRIPTION

MATERIAL TYPE: STEEL.GLASS FINISH :VINTAGE SILVER.BK.FROST TOP COAT/SEALANT:
 SOCKET TYPE: E27 CERAMIC SOCKET QTY:1
 BULB TYPE: TYPE A BULB WATTAGE: 60W VOLTAGE:110V-120V
 ITEM NET WEIGHT:



UL COMPLIANT
 INSTALLATION ENVIRONMENT:SUITABLE FOR DAMP LOCATIONS

NOTE:
 *YOUR PRODUCT(S) MAY BE PACKED IN MORE THAN ONE

PARTS

A	MOUNTING PLATE	1 PC
B	BACK PLATE	1 PC
C	GLASS SHADE	1 PC
D	SHADE FIXER	1 PC
E	PIPE	1 PC
F	HEAD SCREW	1 PC
G	CANOPY SCREW	4 PCS
H	GREEN GROUND SCREW	1 PC

INCLUDED ASSEMBLY HARDWARE

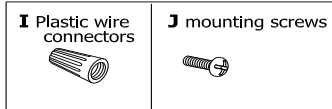

TOOLS NEEDED(INCLUDED)

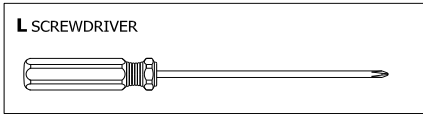

PRODUCT ASSEMBLY

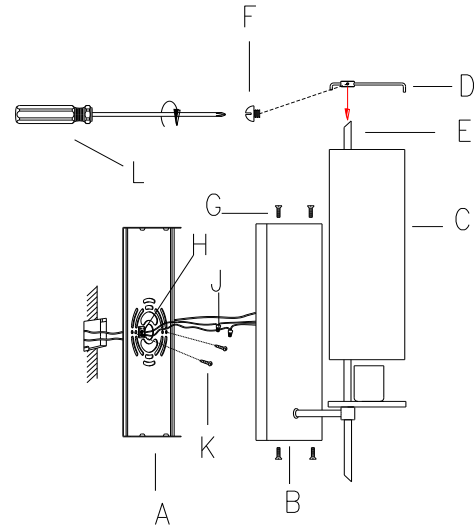

ASSEMBLY INSTRUCTIONS

- 1.REMOVE ALL PACKING CONTENTS AND PARTS FROM THE CARTON(S)CAREFULLY
- 2.PLEASE BE SURE YOU HAVE ALL PARTS INDICATED BEFORE YOU BEGIN ASSEMBLY
- 3.TURN OFF POWER TO THE JUNCTION BOX WHERE THE LAMP WILL BE INSTALLED
- 4.PULL THE ELECTRICAL CORD OF "J BOX"THROUGH THE EXIT HOLE OF THE MOUNTING PLATE(A)
5. ATTACH THE GROUND WIRE FROM THE FIXTURE TO THE GROUND JUNCTION BOX WIRE FROM THE OUTLET (USUALLY GREEN OR BARE WIRE). FASTEN EACH TOGETHER WITH A PLASTIC WIRE CONNECTOR (I) AND WRAP THE CONNECTION WITH ELECTRICAL TAPE. IF YOUR OUTLET BOX DOES NOT HAVE A GROUND WIRE, INSERT THE GREEN GROUND SCREW(H) INTO THE MOUNTING PLATE (A) FACING DOWN, AND WRAP THE FIXTURE'S BARE GROUND WIRE AROUND THE GROUND SCREW. **IT IS IMPERATIVE THAT THE OUTLET BOX IN YOUR HOME BE PROPERLY GROUNDED.**
6. CONNECT THE NEUTRAL FIXTURE WIRE TO THE NEUTRAL JUNCTION BOX WIRE (USUALLY WHITE). FASTEN EACH TOGETHER WITH A WIRE CONNECTOR (I) AND WRAP THE CONNECTION WITH ELECTRICAL TAPE. BE SURE NO STRANDS ARE EXPOSED.
- 7.CONNECT THE HOT FIXTURE WIRE TO THE HOT JUNCTION BOX WIRE (USUALLY BLACK). FASTEN EACH TOGETHER WITH A PLASTIC WIRE CONNECTOR (I) AND WRAP THE CONNECTION WITH ELECTRICAL TAPE. BE SURE NO WIRE STRANDS ARE EXPOSED. **DO NOT REVERSE THE HOT AND NEUTRAL CONNECTIONS OR SAFETY WILL BE COMPROMISED.**
8. GENTLY TUCK THE WIRE CONNECTIONS NEATLY INTO THE CEILING JUNCTION BOX.
- 9.ATTACH THE MOUNTING PLATE (A) TO THE OUTLET BOX USING THE MOUNTING SCREWS(H).TIGHTEN WITH A SCREWDRIVER(L).
- 10.ATTACH THE BACK PLATE(B) TO THE MOUNTING PLATE(A) USING THE ENCLOSED PLATE SCREWS(E). TIGHTEN SCREWS WITH A SCREWDRIVER(L).
- 11.ATTACHED THE GLASS SHADE(C)TO THE SOCKET AND PASS THE PIPE(E)THROUG GLASS SHADE, THEN USE WITH SCREWDRIVER(L) TO THREAD THE HEAD SCREW(F) TO TIGHT THE FIXER(D)TO SECURE THE GLASS SHADE.
- 12.INSTALL A 60W TYPE A BULB(NOT INCLUDED)INTO THREADED SOCKET.DO NOT EXCEED SPECIFIED WATTAGE
- 13.RESTORE POWER TO THE JUNCTION BOX AND TEST FIXTURE.

CARE & MAINTENANCE

DUST WITH A DRY CLOTH.

FOR CUSTOMER SERVICE QUESTIONS CALL 1.888.488.8866
 ARTERIORS HOME:972.488.9800
 ARTERIORS CONTRACT:972.488.9800 EXT.321

DISCLAIMERS

WE RECOMMEND THE INSTALLATION OF THIS ELECTRICAL LIGHT FIXTURE TO BE DONE BY A LICENSED ELECTRICIAN.

ARTERIORS