

ASSEMBLY INSTRUCTIONS

ITEM #89130 | HASKELL OVAL CHANDELIER

ITEM DESCRIPTION

MATERIAL TYPE: STEEL.ACRYLIC ROD FINISH : ANTIQUE BRASS.CLEAR
 SOCKET TYPE: E12 CERAMIC SOCKET QTY:10 TOP COAT/SEALANT:
 BULB TYPE: TYPE B BULB WATTAGE: 40W/or CFL 10W/or LED 9W
 ITEM NET WEIGHT: VOLTAGE:110V-120V
 UL COMPLIANT
 INSTALLATION ENVIRONMENT:SUITABLE FOR DAMP LOCATIONS

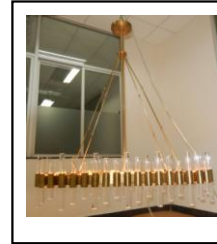



NOTE:
 *YOUR PRODUCT(S) MAY BE PACKED IN MORE THAN ONE CARTON
 *THIS ITEM MAY REQUIRE PERIODIC TIGHTENING

PARTS

A	MOUNTING PLATE	1 PC
B	CANOPY	1 PC
C	COLLAR LOOP	1 PC
D	RODS	5 PCS
E	LOOP PLATE	1 PC
F	HOOK RODS	12 PCS
G	SOCKET ASSEMBL	1 PC
H	ACRYLIC RODS	42 PCS
I	MAIN BODY	1 PC

INCLUDED ASSEMBLY HARDWARE

J Plastic wire connectors 	K mounting screws 	L allen wrench 
--	---	---

PRODUCT ASSEMBLY

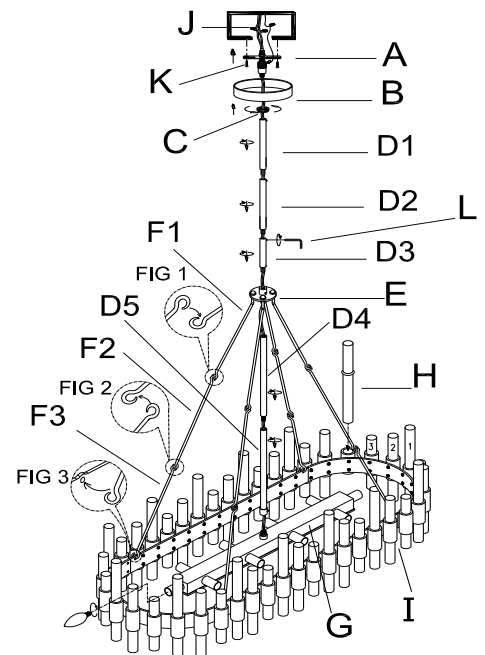

ASSEMBLY INSTRUCTIONS

- 1.REMOVE ALL PACKING CONTENTS AND PARTS FROM THE CARTON(S)CAREFULLY
- 2.PLEASE BE SURE YOU HAVE ALL PARTS INDICATED BEFORE YOU BEING ASSEMBLY
- 3.SHUT OFF THE MAIN ELECTRICAL SUPPLY FROM THE MAIN FUSE BOX/CIRCUIT BREAKER
- 4.SCREW THE ROD(D3) TO THE TOP OF LOOP PLATE(E) ,AND TIGHTEN THE HEXANGULAR SCREW IN THE SIDE DESIRE HOLE BY ALLEN WRENCH(L) . REPEAT THE SAME OPERATION ON THE ROD (D1)AND (D2).
- 5.SCREW ROD (D5) ONTO THE SOCKET ASSEMBLY(G) TILL TIGHT.AND SCREW ROD (D4) ONTO ROD(D5). AND THEN CONNECT WITH LOOP PLATE(E).
6. CONNECT ONE END OF THE HOOK ROD(F3, LONGEST)ON THE MAIN BODY(I) AS FIG 3,AND ANOTHER END ON THE END OF HOOK ROD(F2, MEDIUM) AS FIG 2 AND CONNECT HOOK ROD(F2) TO (F1, SHORTEST)AS FIG 1. REPEAT THE ABOVE OPERATIONS ON THE REMAINING 3 SIDE RODS.
- 7.REMOVE THE MOUNTING PLATE(A)FROM THE CANOPY(B)BY TURNING COLLAR LOOP(C) IN A COUNTER CLOCKWISE DIRECTION.
- 8.CAREFULLY INSPECT THE FIXTURE WIRES. THE NEUTRAL FIXTURE WIRE HAS VERY FINE RIDEGS MOLDED INTO ITS PLASTIC COVERING. THE HOT FIXTURE WIRE HAS A SMOOTH COVERING.THE BARE SILVER WIRE IS THE GROUNDING WIRE.
9. ATTACH THE GROUND WIRE FROM THE FIXTURE TO THE GROUND JUNCTION BOX WIRE FROM THE OUTLET (USUALLY GREEN OR BARE WIRE). FASTEN EACH TOGETHER WITH A PLASTIC WIRE CONNECTOR (J) AND WRAP THE CONNECTION WITH ELECTRICAL TAPE. IF YOUR OUTLET BOX DOES NOT HAVE A GROUND WIRE, INSERT THE GREEN GROUND SCREW INTO THE MOUNTING PLATE (A) FACING DOWN, AND WRAP THE FIXTURE'S BARE GROUND WIRE AROUND THE GROUND SCREW. IT IS IMPERATIVE THAT THE OUTLET BOX IN YOUR HOME BE PROPERLY GROUNDING.
10. CONNECT THE NEUTRAL FIXTURE WIRE TO THE NEUTRAL JUNCTION BOX WIRE (USUALLY WHITE). FASTEN EACH TOGETHER WITH A WIRE CONNECTOR (J) AND WRAP THE CONNECTION WITH ELECTRICAL TAPE. BE SURE NO STRANDS ARE EXPOSED.
- 11.CONNECT THE HOT FIXTURE WIRE TO THE HOT JUNCTION BOX WIRE (USUALLY BLACK). FASTEN EACH TOGETHER WITH A PLASTIC WIRE CONNECTOR (J) AND WRAP THE CONNECTION WITH ELECTRICAL TAPE. BE SURE NO WIRE STRANDS ARE EXPOSED. DO NOT REVERSE THE HOT AND NEUTRAL CONNECTIONS OR SAFETY WILL BE COMPROMISED.
12. GENTLY TUCK THE WIRE CONNECTIONS NEATLY INTO THE CEILING JUNCTION BOX.
- 13.ATTACH THE MOUNTING PLATE (A) WITH NIPPLE TO THE CEILING OUTLET BOX USING THE ENCLOSED MOUNTING SCREWS (K) AND TIGHTEN SCREWS WITH A SCREWDRIVER.
14. PUSH COLLAR LOOP IN CANOPY (B) AND THREAD ONTO NIPPLE IN MOUNTING PLATE (A) BY TURNING IN A CLOCKWISE
- 15.INSERT THE ACRYLIC ROD(H) INTO THE MEAL SLEEVE ACCORDINGLY. REPEAT THE SAME OPERATION ON THE REMAINING 44PCS ACRYLI RODS **PLS NOTE LONGEST,MEDIUM AND SHORTEST ACRYLIC RODS 14PCS EACH AVAILABLE, PLS DISTRIBUTE THEM CYLIC ALTERNATELY.**
- 16.SCREW ROD (D1) TO THE CANOPY (B)BY USING HEXANGULAR SCREW AND ALLEN WRENCH(L) BE SURE ALL THE HEXANGULAR SCREWS ARE TIGHT ENOUGH.
17. INSERT 10 TYPE B 40W BULBS (OR SUITABLE CFL 10W/LED 9W BULBS,NOT INCLUDED)INTO THE SOCKETS. **DO NOT EXCEED SPECIFIED WATTAGE.**

CARE & MAINTENANCE

DUST WITH A DRY CLOTH.

FOR CUSTOMER SERVICE QUESTION CALL 1-800-338-2150

ARTERIOS HOME:972.488.9800

ARTERIOS CONTRACT:972.488.9800 EXT.321

DISCLAIMERS

WE RECOMMEND THE INSTALLATION OF THIS ELECTICAL LIGHT FIXTURE TO BE DONE BY A LICENSED ELECTRICIAN.

ARTERIOS