

# ARTERIOS

## SWAMI LARGE PENDANT

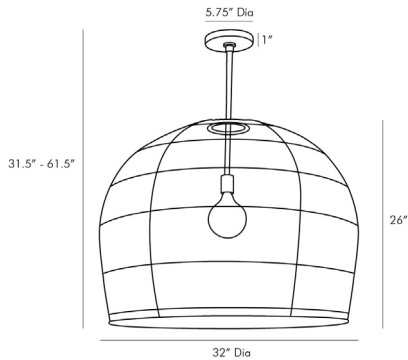

45061  
 H: 31.5 IN, Dia: 32.00 IN  
 Natural & Black Ombre Stained Buri  
 Contract Suitable As Is

Makers utilize old world techniques to create this luxurious and modern piece. Made with hundreds of thin buri sticks, derived from a palm in the Asian tropics, the pendant is formed using traditional techniques practiced to make fishing baskets. Don't let the ancient construction techniques fool you, the bell shape, antique brass pipe kit and ombre finish add contemporary flair. Also comes in a smaller scale (45060). Additional pipe available (PIPE-504). Damp-rated, although limited covered outdoor areas may affect finish.

### APPEARANCE

Material	Buri Midrib, Steel
Finish	Antique Brass, Natural and Black Ombre
Finish Will Vary	true
Top Coat/Sealant	true

### DIMENSIONS

Pendant	H: 26 IN, Dia: 32.00 IN
Minimum Hanging Height	31.5 IN
Maximum Hanging Height	61.5 IN
Canopy	H: 1 IN, Dia: 5.75 IN

### WIRING

	UL,EU,SA
Rating	Damp
Cord	10 FT, Clear/Silver, SVT
Socket	1, Type A- E26 Other
Maximum Watt	150
Voltage	110-120 V

### CERTIFICATIONS

	Mexico
Certifications	European Union, United Arab Emirates, United States, Canada

### COMPLIANCY

UL/ETL	Yes
CB	Yes
RoHS	true

### SHIPPING

Shipping Requirements	TruckShip
Product Weight	15.5 LBS
Gross Weight 1	22 LBS
Gross Weight 2	3 LBS
Shipping Box 1	H: 36 IN, L: 30 IN, W: 30 IN
Shipping Box 2	H: 3 IN, L: 3 IN, W: 10 IN

### ADDITIONAL INFO

Features	Assembly Required,Sustainable
----------	-------------------------------

### REPLACEMENT PARTS

Replacement Part 1	PIPE-504
Replacement Part 1 Dim	(1) 4", (1) 6", (1) 12"
Replacement Part 2	CANOPY-654
Replacement Part 2 Dim	1" x 5.75"

### CONTRACT

Contract Suitable	true
-------------------	------