

ASSEMBLY INSTRUCTIONS

ITEM # 89454 | PENDANT

ITEM DESCRIPTION

MATERIAL TYPE: STEEL, GLASS FINISH : ANTIQUE BRASS, GLASS TOP COAT/SEALANT:
 SOCKET TYPE: E26 CERAMIC SOCKET QTY: 3
 BULB TYPE: TYPE T BULB WATTAGE: 60W or/CFL 12W or/LED 10W VOLTAGE: 110V-120V
 ITEM NET WEIGHT:
 UL COMPLIANT
 INSTALLATION ENVIRONMENT: SUITABLE FOR DAMP LOCATIONS





NOTE:

*YOUR PRODUCT(S) MAY BE PACKED IN MORE THAN ONE CARTON

PARTS

A	MOUNTING PLATE	1 PC
B	CANOPY	1 PC
C	GLASS DISH	1 PC
D	FLAT WASHER	1 PC
E	COLLAR LOOP	1 PC
F	RODS	4 PCS
G	LAMP BODY	1 PC
H	SOCKETS	3 PCS
I	GLASS	46 PCS
L	TURN-KNOBS	46 PCS
M	BULBS(NOT INCLUDED)	1 PC

INCLUDED ASSEMBLY HARDWARE

J mounting screws	K Plastic wire connectors
	

ASSEMBLY INSTRUCTIONS

- REMOVE ALL PACKING CONTENTS AND PARTS FROM THE CARTON(S) CAREFULLY
- PLEASE BE SURE YOU HAVE ALL PARTS INDICATED BEFORE YOU BEGIN ASSEMBLY
- SHUT OFF THE MAIN ELECTRICAL SUPPLY FROM THE MAIN FUSE BOX/CIRCUIT BREAKER.
- CONNECT LAMP BODY(G) AND CANOPY(B) WITH RODS(F1, F2, F3, F4).
NOTE: IF YOU WANT THE FIXTURE TO BE SEMI-FLUSH MOUNT, YOU ONLY NEED CONNECT LAMP BODY(E) AND CANOPY(B) WITH ROD(F4).
- REMOVE THE MOUNTING PLATE(A) FROM THE CANOPY(B) BY TURNING COLLAR LOOP(C) IN A COUNTER CLOCKWISE DIRECTION.
- PULL THE ELECTRICAL CORD OF "J BOX" THROUGH THE EXIT HOLE OF THE MOUNTING PLATE
- CAREFULLY INSPECT THE PENDANT'S FIXTURE WIRES. THE NEUTRAL FIXTURE WIRE HAS VERY FINE RIDGES MOLDED INTO ITS PLASTIC COVERING. THE HOT FIXTURE WIRE HAS A SMOOTH COVERING. THE BARE SILVER WIRE IS THE GROUNDED WIRE.
- ATTACH THE GROUND WIRE FROM THE FIXTURE TO THE GROUND JUNCTION BOX WIRE FROM THE OUTLET (USUALLY GREEN OR BARE WIRE). FASTEN EACH TOGETHER WITH A PLASTIC WIRE CONNECTOR (K) AND WRAP THE CONNECTION WITH ELECTRICAL TAPE. IF YOUR OUTLET BOX DOES NOT HAVE A GROUND WIRE, INSERT THE GREEN GROUND SCREW(H) INTO THE MOUNTING PLATE (A) FACING DOWN, AND WRAP THE FIXTURE'S BARE GROUND WIRE AROUND THE GROUND SCREW. **IT IS IMPERATIVE THAT THE OUTLET BOX IN YOUR HOME BE PROPERLY GROUNDED.**
- CONNECT THE NEUTRAL FIXTURE WIRE TO THE NEUTRAL JUNCTION BOX WIRE (USUALLY WHITE). FASTEN EACH TOGETHER WITH A WIRE CONNECTOR (K) AND WRAP THE CONNECTION WITH ELECTRICAL TAPE. BE SURE NO STRANDS ARE EXPOSED.
- CONNECT THE HOT FIXTURE WIRE TO THE HOT JUNCTION BOX WIRE (USUALLY BLACK). FASTEN EACH TOGETHER WITH A PLASTIC WIRE CONNECTOR (K) AND WRAP THE CONNECTION WITH ELECTRICAL TAPE. BE SURE NO WIRE STRANDS ARE EXPOSED. **DO NOT REVERSE THE HOT AND NEUTRAL CONNECTIONS OR SAFETY WILL BE COMPROMISED.**
- GENTLY TUCK THE WIRE CONNECTIONS NEATLY INTO THE CEILING JUNCTION BOX.
- ATTACH THE MOUNTING PLATE (A) WITH NIPPLE TO THE CEILING OUTLET BOX USING THE ENCLOSED MOUNTING SCREWS (J) AND TIGHTEN SCREWS WITH A SCREWDRIVER.
- PUSH COLLAR LOOP (E), FLAT WASHER(D), GLASS DISH(C) IN CANOPY (B) AND THREAD ONTO NIPPLE IN MOUNTING PLATE (A) BY TURNING IN A CLOCKWISE.
- INSERT 3 TYPE A 60W BULB(OR CFL 12W OR LED 10W, NOT INCLUDED) INTO THE SOCKETS(H). **DO NOT EXCEED SPECIFIED WATTAGE**
- ATTACHED THE GLASS (I) THROUGH THE PIPE AND THREAD THE TURN-KNOBS(L) TO TIGHT TO SECURE THE GLASS SHADE. **NOTE: STARTING AT THE BOTTOM OF THE GLASS.**
- RESTORE POWER TO THE JUNCTION BOX AND TEST FIXTURE.

CARE & MAINTENANCE

DUST WITH A DRY CLOTH.
 FOR CUSTOMER SERVICE QUESTIONS CALL 1.888.488.8866
 ARTERIORS HOME: 972.488.9800
 ARTERIORS CONTRACT: 972.488.9800 EXT.321

DISCLAIMERS

WE RECOMMEND THE INSTALLATION OF THIS ELECTRICAL LIGHT FIXTURE TO BE DONE BY A LICENSED ELECTRICIAN.

PRODUCT ASSEMBLY

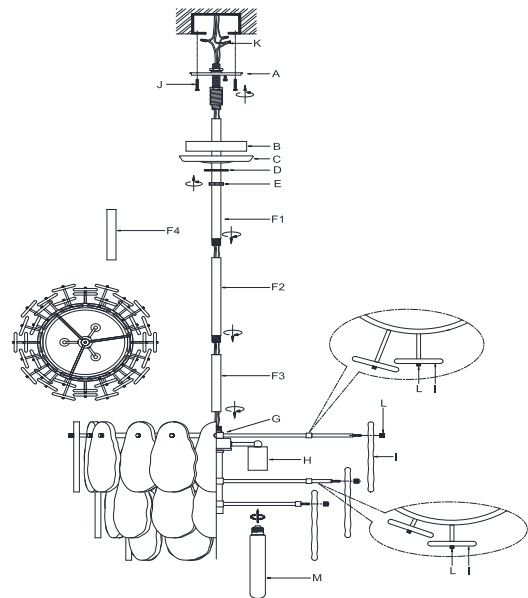

ARTERIORS