

ASSEMBLY INSTRUCTIONS

ITEM #DS49016| Padma Sconce

ITEM DESCRIPTION

MATERIAL TYPE:STEEL,RATTAN FINISH :ANTIQUE BRASS,NATURAL RATTAN
 SOCKET TYPE: E26 CERAMIC SOCKET QTY:1 VOLTAGE:110V-120V
 BULB TYPE: TYPE A BULB WATTAGE: B 40W or/CFL 10W or/LED 9W
 ITEM NET WEIGHT: TOP COAT/SEALANT:



UL COMPLIANT
 INSTALLATION ENVIRONMENT:SUITABLE FOR DAMP LOCATIONS

NOTE:
 *YOUR PRODUCT(S) MAY BE PACKED IN MORE THAN ONE CARTON

PARTS

A	MOUNTING PLATE	1 PC
B	BACK PLATE	1 PC
C	SHADE	1 PC
D	SOCKET CUP	1 PC
E	SOCKET RING	1 PC
F	PLATE SCREW	4 PCS
G	GROUND SCREW	1 PC
H	TURN KNOB	2 PCS

PRODUCT ASSEMBLY

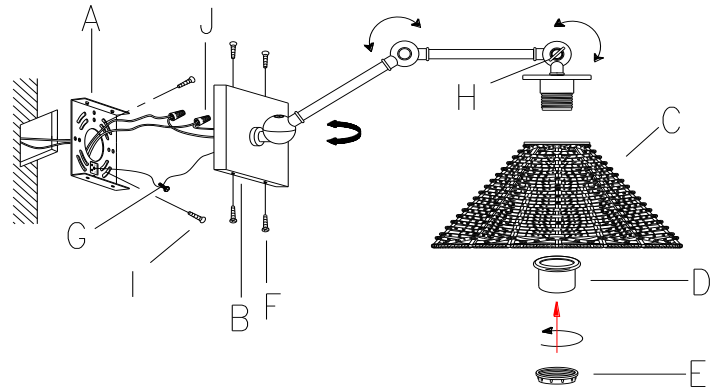

INCLUDED ASSEMBLY HARDWARE

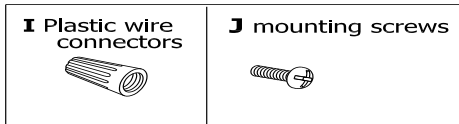

TOOLS NEEDED(NOT INCLUDED)

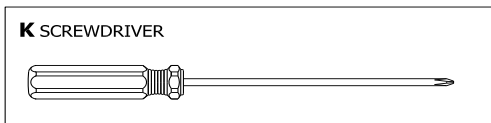

ASSEMBLY INSTRUCTIONS

- 1.REMOVE ALL PACKING CONTENTS AND PARTS FROM THE CARTON(S)CAREFULLY
- 2.PLEASE BE SURE YOU HAVE ALL PARTS INDICATED BEFORE YOU BEGIN ASSEMBLY
- 3.TURN OFF POWER TO THE JUNCTION BOX WHERE THE LAMP WILL BE INSTALLED.
4. REMOVE THE MOUNTING PLATE (A) FROM THE BACK PLATE (B) BY LOOSE PLATE SCREWS(F)
- 5.PULL THE ELECTRICAL CORD OF "J BOX"THROUGH THE EXIT HOLE OF THE MOUNTING PLATE(A)
6. ATTACH THE GROUND WIRE FROM THE FIXTURE TO THE GROUND JUNCTION BOX WIRE FROM THE OUTLET (USUALLY GREEN OR BARE WIRE). FASTEN EACH TOGETHER WITH A PLASTIC WIRE CONNECTOR (I) AND WRAP THE CONNECTION WITH ELECTRICAL TAPE. IF YOUR OUTLET BOX DOES NOT HAVE A GROUND WIRE, INSERT THE GREEN GROUND SCREW(G) INTO THE MOUNTING PLATE (A) FACING DOWN, AND WRAP THE FIXTURE'S BARE GROUND WIRE AROUND THE GROUND SCREW.
IT IS IMPERATIVE THAT THE OUTLET BOX IN YOUR HOME BE PROPERLY GROUNDED.
7. CONNECT THE NEUTRAL FIXTURE WIRE TO THE NEUTRAL JUNCTION BOX WIRE (USUALLY WHITE). FASTEN EACH TOGETHER WITH A WIRE CONNECTOR (I) AND WRAP THE CONNECTION WITH ELECTRICAL TAPE. BE SURE NO STRANDS ARE EXPOSED.
- 8.CONNECT THE HOT FIXTURE WIRE TO THE HOT JUNCTION BOX WIRE (USUALLY BLACK). FASTEN EACH TOGETHER WITH A PLASTIC WIRE CONNECTOR (I) AND WRAP THE CONNECTION WITH ELECTRICAL TAPE. BE SURE NO WIRE STRANDS ARE EXPOSED. **DO NOT REVERSE THE HOT AND NEUTRAL CONNECTIONS OR SAFETY WILL BE COMPROMISED.**
9. GENTLY TUCK THE WIRE CONNECTIONS NEATLY INTO THE CEILING JUNCTION BOX.
- 10.ATTACH THE MOUNTING PLATE (A) TO THE OUTLET BOX USING THE MOUNTING SCREWS(J).TIGHTEN WITH A SCREWDRIVER.
- 11.ATTACH THE BACK PLATE(B) TO THE MOUNTING PLATE(A) USING THE ENCLOSED PLATE SCREWS(F). TIGHTEN SCREWS WITH A SCREWDRIVER(K).
- 12.UNSCREW THE SOCKET RING(E)AND SOCKET CUP(D)OFF THE SOCKET.ATTACH THE SHADE(C) TO THE SOCKET, AND PUSH SOCKET CUP(D), THEN TIGHEN THE SHADE(E) WITH SOCKET RING(E).
- 13.INSTALL ONE TYPE A 40W BULB(OR CFL 10W/LED 9W BULB,NOT INCLUDED)INTO THREADED SOCKET(D).
DO NOT EXCEED SPECIFIED WATTAGE.
- 14.RESTORE POWER TO THE JUNCTION BOX AND TEST FIXTURE

NOTE:
 PLEASE NOTED THE BODY OR SHADE CAN BE SWIVELED AS ARROWS SHOW.TO LOOSEN AND TIGHTEN TURN KNOBS(H)TO ADJUST THE SCONCE.

CARE & MAINTENANCE

DUST WITH A DRY CLOTH.

DISCLAIMERS

FOR CUSTOMER SERVICE QUESTIONS CALL 1-800-338-2150

WE RECOMMEND THE INSTALLATION OF THIS ELECTRICAL LIGHT FIXTURE TO BE DONE BY A LICENSED ELECTRICIAN.

ARTERIORS HOME:972.488.9800

ARTERIORS CONTRACT:972.488.9800 EXT.321

ARTERIORS