

ASSEMBLY INSTRUCTIONS

ITEM #89032 | DALLAS CHANDELIER

ITEM DESCRIPTION

MATERIAL TYPE: STEEL, GLASS FINISH: POLISHED NICKEL TOP COAT/SEALANT:
 SOCKET TYPE: E12 CERAMIC SOCKET QTY: 18
 BULB TYPE: TYPE G BULB WATTAGE: 25W VOLTAGE: 110V-120V
 ITEM NET WEIGHT:

UL COMPLAINT

INSTALLATION ENVIRONMENT: DRY LOCATION ONLY





NOTE:

*YOUR PRODUCT(S) MAY BE PACKED IN MORE THAN ONE CARTON

PARTS

A	MOUNTING PLATE	1 PC
B	CANOPY	1 PC
C	COLLAR LOOP	1 PC
D	RODS	3 PCS
E	MAIN BODY	1 PC
F	GLASS SPHERE	18 PCS
G	SOCKET ASSEMBLY	18 PCS
H	METAL CAP	18 PCS

INCLUDED ASSEMBLY HARDWARE

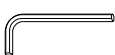
I Plastic wire connectors 	J mounting screws 	K allen wrench 
---	---	--

PRODUCT ASSEMBLY

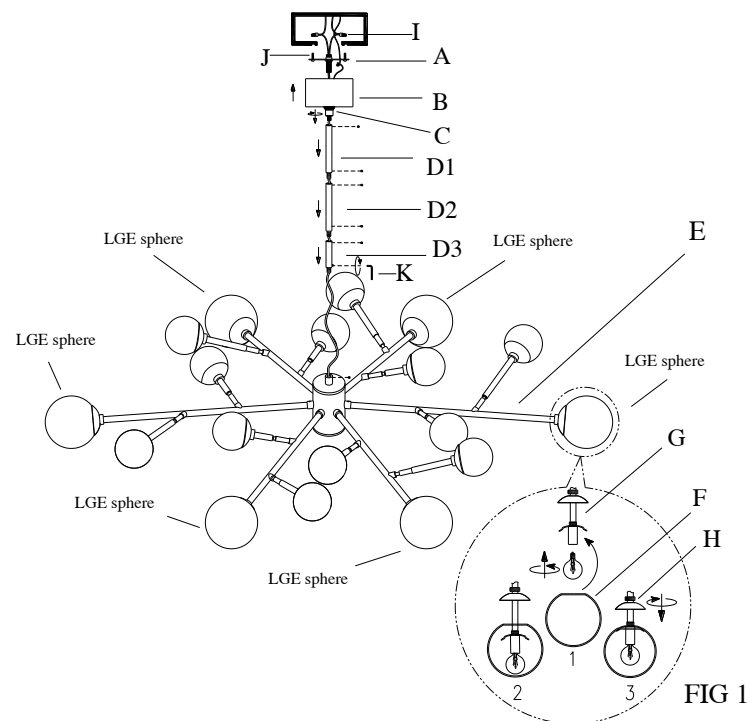

ASSEMBLY INSTRUCTIONS

1. REMOVE ALL PACKING CONTENTS FROM THE CARTON(S) CAREFULLY
2. REMOVE ALL PARTS FROM THE PACKAGE(S) CAREFULLY
3. SHUT OFF THE MAIN ELECTRICAL SUPPLY FROM THE MAIN FUSE BOX/CIRCUIT BREAKER
4. SCREW THE ROD(D3) TO THE MAIN BODY (E), AND TIGHTEN THE HEXANGULAR SCREW IN THE SIDE HOLE WITH ALLEN WRENCH(K). REPEAT THE SAME OPERATION ON THE ROD (D1) AND (D2).
5. AS FIG 1, UNSCREW THE METAL CAP(H) OFF THE SOCKET ASSEMBLY(G), INSERT TYPE G 25W BULB (NOT INCLUDED) IN THE SOCKET THEN ATTACH THE GLASS SPHERE TO THE SOCKET PROPERLY, THEN SCREW THE METAL CAP(H) TO SECURE THE GLASS SPHERE TILL TIGHT. REPEAT THE ABOVE OPERATION ON THE REMAINING 5 BIG GLASS SPHERE AND 12 SMALL GLASS SPHERE
6. REMOVE THE MOUNTING PLATE(A) FROM THE CANOPY(B) BY TURNING COLLAR LOOP(C) IN A COUNTER CLOCKWISE DIRECTION.
7. CAREFULLY INSPECT THE PENDANT'S FIXTURE WIRES. THE NEUTRAL FIXTURE WIRE HAS VERY FINE RIDGES MOLDED INTO ITS PLASTIC COVERING. THE HOT FIXTURE WIRE HAS A SMOOTH COVERING. THE BARE SILVER WIRE IS THE GROUNDED WIRE.
8. ATTACH THE GROUND WIRE FROM THE FIXTURE TO THE GROUND JUNCTION BOX WIRE FROM THE OUTLET (USUALLY GREEN) OR BARE WIRE). FASTEN EACH TOGETHER WITH A PLASTIC WIRE CONNECTOR (I) AND WRAP THE CONNECTION WITH ELECTRICAL TAPE. IF YOUR OUTLET BOX DOES NOT HAVE A GROUND WIRE, INSERT THE GREEN GROUND SCREW INTO THE MOUNTING PLATE (A) FACING DOWN, AND WRAP THE FIXTURE'S BARE GROUND WIRE AROUND THE GROUND SCREW. IT IS IMPERATIVE THAT THE OUTLET BOX IN YOUR HOME BE PROPERLY GROUNDED.
9. CONNECT THE NEUTRAL FIXTURE WIRE TO THE NEUTRAL JUNCTION BOX WIRE (USUALLY WHITE). FASTEN EACH TOGETHER WITH A WIRE CONNECTOR (I) AND WRAP THE CONNECTION WITH ELECTRICAL TAPE. BE SURE NO STRANDS ARE EXPOSED.
10. CONNECT THE HOT FIXTURE WIRE TO THE HOT JUNCTION BOX WIRE (USUALLY BLACK). FASTEN EACH TOGETHER WITH A PLASTIC WIRE CONNECTOR (G) AND WRAP THE CONNECTION WITH ELECTRICAL TAPE. BE SURE NO WIRE STRANDS ARE EXPOSED. DO NOT REVERSE THE HOT AND NEUTRAL CONNECTIONS OR SAFETY WILL BE COMPROMISED.
11. GENTLY TUCK THE WIRE CONNECTIONS NEATLY INTO THE CEILING JUNCTION BOX.
12. ATTACH THE MOUNTING PLATE (A) WITH NIPPLE TO THE CEILING OUTLET BOX USING THE ENCLOSED MOUNTING SCREWS (J) AND TIGHTEN SCREWS WITH A SCREWDRIVER.
13. PUSH COLLAR LOOP IN CANOPY (B) AND THREAD ONTO NIPPLE IN MOUNTING PLATE (A) BY TURNING IN A CLOCKWISE
14. SCREW ROD (D1) TO CANOPY (C), USING HEXANGULAR SCREW AND ALLEN WRENCH(J) BE SURE ALL THE HEXANGULAR SCREWS ARE TIGHT ENOUGH.

CARE & MAINTENANCE

FOR CUSTOMER SERVICE QUESTION CALL 1.888.488.8866

ARTERIORS HOME: 972.488.9800

ARTERIORS CONTRACT: 972.488.9800 EXT.321

DISCLAIMERS

WE RECOMMEND THE INSTALLATION OF THIS ELECTRICAL LIGHT FIXTURE TO BE DONE BY A LICENSED ELECTRICIAN.