

MAGNOLIA 60" DOUBLE SINK BASE CABINET

ARIEL

S060D



BASE CABINET DIMENSIONS

60" W x 21.5" D x 34.5" H

FEATURES

- Solid wood frame & plywood panels
- Dovetail drawers and joints
- Soft closing doors & drawers

HARDWARE FINISHES



Brushed Nickel Satin Brass Matte Black Polished Chrome

AVAILABLE COLORS



White Grey Midnight Blue

FRONT VIEW

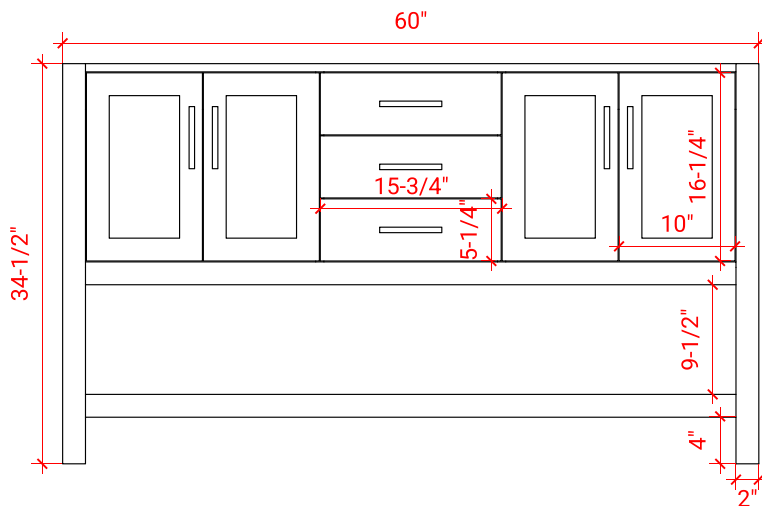

SIDE VIEW

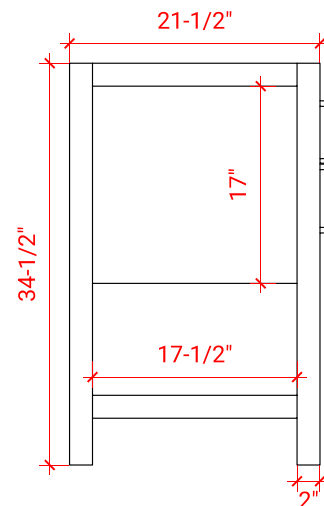

PLAN VIEW

