

Aqua-Pure®

Models:

AP200

Drinking Water System

Spec # _____

Quantity _____

Applications:

- Chlorine Taste & Odor
- Particulate*

At a Glance:

- Reduces particulate* and chlorine taste & odor
- Space saving, compact design
- Premium performance dual action AP217 cartridge included
- Mounting bracket included
- Made from FDA CFR-21 Compliant materials



AP200

Product Benefits:

- Space saving design helps provide easy installation under sink or in confined spaces
- System helps provide high flow rate to 1.75 gpm (6.6 lpm) to all standard kitchen and bathroom faucets
- Helps provide multi-stage filtration process for clearer, cleaner, better tasting water with high efficiency chlorine taste & odor and particulate* reduction in one system
- Designed with specially formulated high-adsorption activated carbon to help provide effective filtration of unwanted chlorine taste and odor
- Premium performance pre-filter for high particulate* reduction efficiency
- System tested and certified by NSF International
- 5 year limited warranty

Product Specifications:

Model No. (Part No.)	Inlet/ Outlet Size	Dimensions		Approx. Weight	Flow Rate	Clean Pressure Drop	Max. Water Temp.	Max. Water Pressure	Standard Repl. Ctg. No.	Repl. Ctg. Qty.	Degree of Filtration
		Height	Diameter								
AP200 (55289-01)	3/8" NPT	9-13/16" (24.9 cm)	4-7/8" (12.4 cm)	2.8 lbs. (1.3 kg)	1.75 gpm (6.6 lpm)	N/A	100°F (37.8°C)	125 psi (862 kPa)	AP217	1	5 micron nominal

* Tested and verified by manufacturer's laboratory



Aqua-Pure®

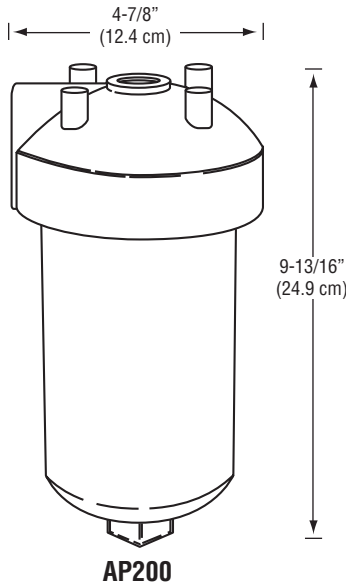

AP200

Easy Installation:

CAUTION: Diagram shown is for reference purposes only. Read installation and operation manual prior to installing the unit.

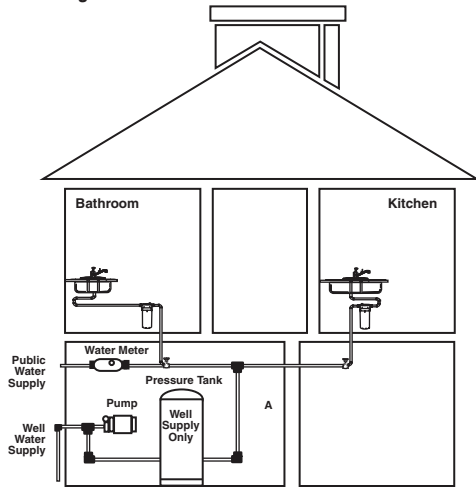

Spec # _____

Quantity _____

Model Number _____

Part Number _____

Specifications:

- Standard 3/8" NPT inlet/outlet connections
- System is a single vessel design
- System is manufactured from FDA CFR-21 compliant materials
- System has maximum operating pressure of 125 psi (862 kPa) and operating temperature of 100°F (37.8°C)
- System to be installed on primary kitchen or bath cold water faucet

Replacement Cartridge Options

Model	Sediment Load	Nominal Micron Rating	Application		Flow Rate
			Particulate*	Chlorine Taste & Odor	
AP217	Normal	5	•	•	1.75 gpm (6.6 lpm)

* Tested and verified by manufacturer's laboratory

⚠ WARNING: To reduce the risk associated with the ingestion of contaminants:

- Do not use with water that is microbiologically unsafe or of unknown quality without adequate disinfection before or after the system.

3M Purification Inc. recommends regularly scheduled maintenance and replacement of the filter cartridge(s) in order for the product to perform as advertised/sold. 3M Purification Inc. shall not be liable for system failures due to improper maintenance.

CAUTION: To reduce the risk associated with property damage due to water leakage:

- The disposable filter cartridge **MUST** be replaced every six (6) months, at the rated capacity or sooner if a noticeable reduction in flow rate occurs.

Limited Warranty:

Limited Warranty: 3M Purification Inc. warrants this Product will be free from defects in material and manufacture for five (5) years from the date of purchase. The filter cartridge or filter membrane is warranted to be free from defects in material and manufacture for one (1) year. This warranty does not cover failures resulting from abuse, misuse, alteration or damage not caused by 3M Purification Inc. or failure to follow installation and use instructions. No warranty is given as to the service life of any filter cartridge or membrane as it will vary with local water conditions and water consumption. **3M PURIFICATION INC. MAKES NO OTHER WARRANTIES OR CONDITIONS, EXPRESS OR IMPLIED, INCLUDING, BUT NOT LIMITED TO, ANY IMPLIED WARRANTY OR CONDITION OF MERCHANTABILITY OR FITNESS FOR A PARTICULAR PURPOSE OR ANY IMPLIED WARRANTY OR CONDITION ARISING OUT OF A COURSE OF DEALING, CUSTOMER OR USAGE OF TRADE.** If the Product fails to satisfy this Limited Warranty during the warranty period, 3M Purification Inc. at its option will replace the Product or refund your Product purchase price. This warranty does not cover labor. **The remedy stated in this paragraph is Customer's sole remedy and 3M Purification Inc.'s exclusive obligation.** For additional information, see the entire Limited Warranty located in the product Installation and Operating Instruction Manual.

Limitation of Liability. 3M Purification Inc. will not be liable for any loss or damage arising from this 3M Purification Inc. product, whether direct, indirect, special, incidental, or consequential, regardless of the legal theory asserted, including warranty, contract, negligence or strict liability. Some states and countries do not allow the exclusion or limitation of incidental or consequential damages, so the above limitation or exclusion may not apply to you.

Distributed by:

3M

3M Purification Inc.
400 Research Parkway
Meriden, CT 06450 U.S.A.
Toll Free: 1.800.222.7880
Worldwide: 203.237.5541
Fax: 203.238.8701
www.aquapure.com • www.3mpurification.com



Visit www.nsf.org for the claims associated with products that are NSF listed.

Aqua-Pure is a trademark of 3M Company used under license
3M is a trademark of 3M Company
NSF is a trademark of NSF International.
© 2011 3M Company. All rights reserved.
70-0201-9243-4 REV 1111