



INSTALLATION AND OPERATING INSTRUCTIONS

APIF SERIES RESIDENTIAL IRON AND MANGANESE REDUCTION SYSTEMS

Models

APIF100	APIF100J	APIF100M	APIF100PT	APIF100MPT	APIF100MJ
APIF100DM	APIF100PTDM	APIF100MDM	APIF100MPTDM		
APIF150	APIF150J	APIF150M	APIF150PT	APIF150MPT	APIF150MJ
APIF150DM	APIF150PTDM	APIF150MDM	APIF150MPTDM		
APIF200	APIF200J	APIF200M	APIF200PT	APIF200MPT	APIF200MJ
APIF200DM	APIF200PTDM	APIF200MDM	APIF200MPTDM		
APIF300	APIF300J	APIF300M	APIF300PT	APIF300MPT	APIF300MJ

Installer, please leave with homeowner.
Homeowner, retain for future reference.





SAFETY INFORMATION

Read, understand, and follow all safety information contained in these instructions prior to installation and use of the APIF Series Residential Iron and Manganese Reduction System. Retain these instructions for future reference. Failure to follow installation, operation and maintenance instructions may result in property damage and will void warranty.

Intended use:

The APIF Series Residential Iron and Manganese Reduction Systems are intended for use in homes and have not been evaluated for other uses. These systems are intended to be installed near the entry point of a home water line, and must be installed by qualified professional installers or licensed plumbing contractors in accordance with state and local plumbing codes and these installation instructions.

EXPLANATION OF SIGNAL WORD CONSEQUENCES

 WARNING	Indicates a potentially hazardous situation, which, if not avoided, could result in death or serious injury and/or property damage.
 CAUTION	Indicates a potentially hazardous situation, which, if not avoided, may result in minor or moderate injury and/or property damage.
CAUTION	Indicates a potentially hazardous situation, which, if not avoided, may result in property damage.

WARNING

To reduce the risk associated with choking:

- Do not allow children under 3 years of age to have access to small parts during the installation of this product.

To reduce the risk associated with ingestion of contaminants:

- Do not use with water that is microbiologically unsafe or of unknown quality without adequate disinfection before or after the system.

To reduce the risk of physical injury:

- Shut off inlet water supply and depressurize system as shown in manual prior to service.

To reduce the risk associated with a hazardous voltage:

- If the home electrical system requires use of the cold water system as an electrical safety ground, a jumper must be used to ensure a sufficient ground connection across the filter installation piping — refer installation to qualified personnel.
- Do not use the system if the power cord is damaged — contact qualified service personnel for repair.

To reduce the risk associated with back strain due to the heavy weight of the various system components:

- Follow safe lifting procedures.

CAUTION

To reduce the risk associated skin, eye, and respiratory tract irritation from gravel and filter media during installation:

- Gravel and several types of filter media may be used in this product, depending upon the application. During installation, dust may cause irritation to skin, eyes, and respiratory tract.
- Utilize a NIOSH-approved dust filter mask, protective gloves, and appropriate eye protection when handling and pouring gravel and filter media.
- To request an MSDS relating to the media shipped with this product, call 203-238-8965 or go to www.3M.com, select country, and use the search engine to search MSDS. For emergencies, call 800-364-3577 or 651-737-6501 (24 hours).

CAUTION

To reduce the risk associated with skin, eye, and respiratory tract irritation from water treatment chemicals:

- Several types of water treatment chemicals may be used in this product, depending upon the application. During installation and use, exposure may cause irritation to skin, eyes, and respiratory tract.
- Utilize a NIOSH-approved dust filter mask, protective gloves, and appropriate eye protection when handling and pouring gravel and filter media.
- To request an MSDS relating to the media shipped with this product, call 203-238-8965 or go to www.3M.com, select country, and use the search engine to search MSDS. For emergencies, call 800-364-3577 or 651-737-6501 (24 hours).

CAUTION

To reduce the risk associated with property damage due to water leakage:

- **Read and follow** Use instructions before installation and use of this water treatment system.
- Installation and use **MUST** comply with existing state or local plumbing codes.
- **Protect from freezing**, relieve pressure and drain system when temperatures are expected to drop below 33°F (0.6°C).
- **Do not** install on hot water supply lines. The maximum operating water temperature of this filter system is 110°F (43.3°C).
- **Do not** install systems in areas where ambient temperatures may go above 110° F (43.3° C).
- **Do not** install if water pressure exceeds 125 psi (861 kPa). If your water pressure exceeds 80 psi (552 kPa), you must install a pressure limiting valve. Contact a plumbing professional if you are uncertain how to check your water pressure.
- **Do not** install where water hammer conditions may occur. If water hammer conditions exist you must install a water hammer arrester. Contact a plumbing professional if you are uncertain how to check for this condition.
- Where a backflow prevention device is installed on a water system, a device for controlling pressure due to thermal expansion must be installed.
- **Do not** use a torch or other high temperature sources near filter system, cartridges, plastic fittings or plastic plumbing.
- On plastic fittings, never use pipe sealant or pipe dope. **Use PTFE thread tape only**, pipe dope properties may deteriorate plastic.
- Take care when using pliers or pipe wrenches to tighten plastic fittings, as damage may occur if over tightening occurs.
- **Do not** install in direct sunlight or outdoors.
- Mount system in such a position as to prevent it from being struck by other items used in the area of installation.
- Ensure all tubing and fittings are secure and free of leaks.
- **SHUT OFF FUEL OR ELECTRIC POWER SUPPLY TO WATER HEATER** after water is shut off.
- **Do not** install system where water lines could be subjected to vacuum conditions without appropriate measures for vacuum prevention.
- **Do not** apply heat to any fitting connected to bypass or control valve as damage may result to internal parts or connecting adapters.
- Install on a flat/level surface. It is also advisable to sweep the floor to eliminate objects that could pierce the media tank.

To reduce the risk associated with property damage due to plugged water lines:

- Pay particular attention to correct orientation of control valve. Water flow should match arrow on control valve. The inlet and outlet of other water treatment equipment products will vary depending on the control valve brand used.

IMPORTANT NOTES

- Failure to follow instructions will void warranty.

TABLE OF CONTENTS

<u>SECTION</u>	<u>DESCRIPTION</u>
1	GENERAL INFORMATION
2	BEFORE INSTALLATION
3	IMPORTANT INSTALLATION INSTRUCTIONS
4	BACKWASHING INSTRUCTIONS
5	TROUBLESHOOTING
6	SPECIFICATION AND OPERATING DATA
7	MAINTENANCE
8	LIMITED WARRANTY

SECTION 1: GENERAL INFORMATION

Congratulations on your purchase of an APIF Series Residential Iron and manganese reduction system! The iron and manganese reduction system reduces dissolved, precipitated and bacterial iron and manganese, naturally elevates pH and reduces low levels of hydrogen sulfide gas from your water supply. Contrary to conventional methods, your iron and manganese reduction system requires NO chemicals (either added to the water supply or the filter). This unique process requires ONLY periodic backwashing for a few minutes to flush out entrapped iron that has accumulated in the media tank.

When properly installed, operated and maintained, the iron and manganese reduction system will provide many years of dependable service. Read this manual all the way through first, and then follow the instruction steps in the proper sequence.

The iron and manganese reduction system is intended to be used on residential water systems which use a standard submersible well pump, one that utilizes a pressure tank and a pressure switch to stop and start the well pump. If you have a jet pump or a constant pressure pump you will need to utilize another product type to address your iron, manganese and hydrogen sulfide problems. Please contact our technical department should you have any questions at 1-800-222-7880 and select option 1.

- **Professional Installation Required:** Installation requires shutting water off to home, cutting home water supply pipe and using a soldering kit to add piping and fittings. Specialized tools and skills are required. Not a do-it-yourself type of project. Professional installation **required!**

Description and Operation of the System:

The iron and manganese reduction system consists of two major components which are:

- 1) HYDRO-CHARGER located between the well head and the pressure tank, which adds a small amount of air to the iron-laden water whenever the well pump runs.
- 2) A backwashing type filter containing a special media that causes the iron in the "hydro-charged" water to precipitate throughout the filter bed (rather than on the surface as in chemical oxidizing filters). The media DOES NOT require a chemical regenerant (such as potassium permanganate) for oxygen enrichment, salt, chlorine or any other chemicals.

Your iron and manganese reduction system automatically adjusts the pH to neutral or higher on acid water WITHOUT an acid neutralizer (a required piece of equipment with chemical oxidation filters whenever the pH is less than 6.7). The ability to raise pH when it is below neutral (7 or less) greatly enhances the iron and manganese reduction system's ability to reduce iron efficiently.

IMPORTANT NOTE

- Replenishment of the component of the filter media that adjusts pH may be required periodically, the frequency of which is dependent on the raw water pH, the manganese (Mn) concentration in the water (if any) and the water consumption rate.

Periodic regeneration of the filter bed flushes the precipitated iron to the drain and readies the filter for use again. The regeneration cycle includes both a backwash and rapid rinse position, but generally totals just 10 minutes (factory setting). The frequency of regeneration depends on iron concentration and water usage, and ranges from daily to once every 99 days. The volume of water consumed during the entire backwashing procedure is approximately 53 gallons at the factory backwash settings (one (1) cubic foot models).

SECTION 2: BEFORE INSTALLATION

Inspecting And Handling Your Filter:

Inspect the equipment for shipping damage. If damaged, notify the transportation company and request a damage inspection. Handle the filter with care. Damage can occur if dropped or set on sharp, uneven projections on the floor. Do not turn the filter upside down. Installation must comply with state and local laws and regulations.

Make Sure Your Water Has Been Thoroughly Tested:

An analysis of your water should be made prior to the selection of your water conditioning equipment. Your dealer will generally perform this service for you, and may send a sample to the factory for analysis and recommendations. Enter your analysis below for your permanent record.

Analysis of Your Water:

Hardness _____	gpg	Tannins (Humic Acid) _____	ppm
Iron (Fe) _____	ppm	Hydrogen Sulfide (H ₂ S) _____	ppm
Manganese (Mn) _____	ppm	Other _____	ppm
pH _____	ppm	Other _____	ppm

IMPORTANT NOTES

Hydrogen sulfide (H₂S) must be tested for at the well site. For accuracy, the sample must be drawn with the pump RUNNING, and the test be completed within ONE minute after the sample is drawn.

Iron (Fe)

Iron concentrations as low as 0.3 ppm (0.1 ppm under some conditions) will cause staining. The iron concentration, together with the flow rate demand and the consumption rate of the water determines the size of the filter system required. The higher these factors are, the larger the required system. The iron and manganese reduction system is capable of reducing the three main types of iron found in water supplies: dissolved iron; precipitated iron; and bacterial iron. There is an upper limit of 15 ppm iron concentration for the iron and manganese reduction system; special care must be taken when selecting a filter model if your water has a combination of high iron, very low pH and/or manganese levels above 0.2 ppm.

The iron and manganese reduction system is not bactericidal, i.e. it does not remove or kill "bacterial iron". It reduces the iron upon which the bacteria may live or which it deposits in your plumbing fixtures, thus helping to minimize its effects.

Manganese (Mn)

The presence of manganese can be bothersome, even for an iron and manganese reduction system (and is problematic for chemical oxidizing systems because the chemicals may not allow for the correct pH for Manganese Reduction). As little as 0.05 ppm of manganese can produce a brownish or black stain. The ability of the iron and manganese reduction system to reduce manganese depends on its concentration and the pH of the water.

The oxidation of manganese is very similar to that of iron, therefore, a pH of 8.2 or higher must be obtained. When this pH level is achieved, the precipitation of manganese may more readily occur. To accomplish this, models are available where the media contains additional quantities of pH Plus, the pH raising component (model designations with "M" suffix). In any application involving manganese, a larger model filter is generally recommended (but only if the pumping rate is sufficient to backwash the larger size).

If, however, the manganese concentration is low (0.1 ppm or less) and the pH is 6.5 or higher, an iron and manganese reduction system containing standard iron and manganese reduction system media will generally perform satisfactorily, although backwashing should be performed at more frequent intervals. Under more severe conditions where the pH is very low and/or the manganese concentration is high, an acid neutralizer installed ahead of the iron and manganese reduction system will maintain the required 8.2 pH level longer than the chem-free media.

pH

The pH of water measures the hydrogen ion concentration. Water with a pH of less than 7.0 is base, above 7.0 it is alkaline, and a pH of 7.0 is neutral. The lower the pH value, the greater the acidity, and the higher the pH value, the more base. Acidic water (pH less than 7.0) is corrosive to pipes, appliances, etc. A pH of 7.0 or higher facilitates iron reduction, which is why the iron and manganese reduction system is designed to increase the pH when it is less than 7.0.

The pH increasing component of chem-free media is "sacrificial", that is, it slowly dissolves during the process of increasing pH. The rate at which this occurs is proportional to the degree of the pH increase and the water consumption rate (i.e., the greater the pH increase and water consumption, the greater the sacrificial rate). Thus, when the pH is increased to 8.2 or more, as is necessary when manganese is present, the sacrificial rate is even greater. Under the most severe conditions, the pH Plus component of the media may have to be replenished two to four times per year. On the other hand, if the raw water pH is 7.0 or above and no manganese is present, the sacrificial rate is very slight (see IMPORTANT NOTE, Section 1).

Tannins (Humic Acid)

Tannins (a humic acid), which may be present in some water supplies, are the result of various forms of decaying vegetation (the test for tannins can be performed by your dealer). Tannins can cause problems in the operation of the iron and manganese reduction system by forming a sticky coating on the media, thus rendering it incapable of filtering the iron. Generally with tannin concentrations of **0.5 ppm or less**, more frequent backwashing will help prevent the sticky coating from forming. It does appear, however, that the level of tannin concentration affects the operation of the chem-free filter differently in different geographical areas (in some areas, the iron and manganese reduction system will perform satisfactorily when tannin concentration is considerably greater than 0.5 ppm). It is therefore recommended that if the tannin concentration is **0.5 ppm or more**, contact your dealer BEFORE installing the system.

Hydrogen Sulfide (H₂S)

Hydrogen sulfide gas is easily detected by its objectionable "rotten egg" odor. Whenever hydrogen sulfide is present, backwashing must be performed at more frequent intervals, and the pumping system **MUST** include a standard air-to-water pressure tank with an air-relief valve. The air to water pressure tank must be installed between the hydro-charger and existing pressure tank.

Check Your Water Pressure and Pumping Rate:

Two water system conditions must be checked carefully to avoid unsatisfactory operation or equipment damage:

- 1) **MINIMUM** water pressure required at the media tank inlet is 20 psi. **If pressure is over 80 psi, a pressure reducing valve must be installed in the water supply line ahead of the hydro-charger. NOTE: Do not install if water pressure exceeds 125 psi (861 kPa). If your water pressure exceeds 80 psi (552 kPa), you must install a pressure limiting valve. Contact a plumbing professional if you are uncertain how to check your water pressure. If you have a private well, the gauge on the pressure tank will indicate the high and low system pressure. Record your water pressure date below:**

Water Pressure

Low _____ PSI High _____ PSI

CAUTION

To reduce the risk associated with property damage due to water leakage:

- **Do not** install system where water lines could be subjected to vacuum conditions without appropriate measures for vacuum prevention.

- 2) The pumping rate of your well pump must be sufficient for satisfactory operation of the hydro-charger and to backwash the filter. **For model APIF100, the required rate is 5 gpm (refer to Specifications and Operating Data for the backwash requirements for other models). To measure the pumping rate of your pump, follow these instructions:**

- a. Make certain no water is being drawn. Open spigot nearest pressure tank. When pump starts, close spigot and measure time (in seconds) to refill pressure tank (when pump shuts off). This figure represents Cycle Time.
- b. With the pressure tank full, draw water into a container of known volume, measure the number of gallons drawn until the pump starts again. This is the Draw-Down. Divide this figure by Cycle Time and multiply the result by 60 to arrive at the Pumping Rate in gallons per minute (gpm). To aid in your calculation, insert the data in the following formula:

Draw-Down _____(gallons) ÷ Cycle Time _____(seconds) x 60 = Pumping Rate _____(gpm)

Example: Cycle Time is 63 seconds; Draw-Down is 8 gallons, then Pumping Rate equals:

8 gallons ÷ 63 seconds x 60 = 7.8 gpm

NOTE: The addition of the hydro-charger to the pumping system or plumbing and other water treatment devices (such as an acid neutralizer) may reduce the flow rate at the drain to an inadequate level to properly backwash the system. If you are uncertain whether your flow rate is adequate, contact your dealer **BEFORE** installing your iron and manganese reduction system so that corrective action, if required, may be taken.

CAUTION

To reduce the risk associated with property damage due to water leakage:

- Install on a flat/level surface. It is also advisable to sweep the floor to eliminate objects that could pierce the media tank.
- **Protect from freezing**, relieve pressure and drain system when temperatures are expected to drop below 33°F (0.6°C).
- **Do not** install on hot water supply lines. The maximum operating water temperature of this filter system is 110°F;
- **Do not** install if water pressure exceeds 125 psi (861 kPa). If your water pressure exceeds 80 psi (552 kPa), you must install a pressure limiting valve. Contact a plumbing professional if you are uncertain how to check your water pressure;
- **Do not** install where water hammer conditions may occur. If water hammer conditions exist you must install a water hammer arrester. Contact a plumbing professional if you are uncertain how to check for this condition;
- **Do not** install in direct sunlight or outdoors.

Locate Water Conditioning Equipment Correctly:

Select the location of your iron and manganese reduction system with care. Various conditions which contribute to proper location are as follows:

- 1) Locate as close as possible to water supply source.
- 2) Locate as close as possible to a drain.
- 3) Locate in correct relationship to other water conditioning equipment (Figure 1, page 3-1).
- 4) Locate the system in the supply line BEFORE the water heater. Temperatures above 110°F (43.3°C) will damage the system and void the factory warranty.
- 5) DO NOT install the system in a location where freezing temperatures occur. Freezing may cause permanent damage and will also void the factory warranty.
- 6) Allow sufficient space around the installation for easy servicing.
- 7) Provide a non-switched 110V, 60Hz (220V, 50Hz for specified systems) power source for the control valve.

WARNING

To reduce the risk associated with ingestion of contaminants:

- Do not use with water that is microbiologically unsafe or of unknown quality without adequate disinfection before or after the system.

CAUTION

To reduce the risk associated with property damage due to water leakage:

- **Protect from freezing**, relieve pressure and drain system when temperatures are expected to drop below 33°F (0.6°C).
- Do not install on hot water supply lines. The maximum operating water temperature of this filter system is 110°F (43.3°C).

The Importance of Your Pressure Tank:

The pressure tank found on private well systems becomes an integral part of the iron and manganese reduction system by providing necessary mixing and “residence time” to the “hydro-charged” water. While the iron and manganese reduction system will perform satisfactorily with either a captive-air (bladder) type pressure tank or a standard air-to-water type with an air volume control (air-relief valve), the bladder type requires more careful adjustment of the hydro-charger to prevent gasses from collecting in the pressure tank and the head area of the media tank.

Under more severe operating conditions (low pH, high iron, manganese, and small concentrations of sulfur), a standard air-to-water type pressure tank with an air-relief valve MUST be used (if a bladder type tank is already in place, do not remove it, install the air-to-water pressure tank between the hydro-charger and the bladder type tank).

IMPORTANT NOTE

If your pressure tank (or any part of your water system) is not functioning properly, corrective action MUST be taken before installation of your iron and manganese reduction system.

CAUTION

To reduce the risk associated with property damage due to water leakage:

- Do not use a torch or other high temperature sources near filter system, cartridges, plastic fittings or plastic plumbing;
- On plastic fittings, never use pipe sealant or pipe dope. **Use PTFE thread tape only**, pipe dope properties may deteriorate plastic;
- Take care when using pliers or pipe wrenches to tighten plastic fittings, as damage may occur if over tightening occurs.

To reduce the risk associated with property damage due to plugged water lines:

- Pay particular attention to correct orientation of control valve. Water flow should match arrow on control valve. The inlet and outlet of other water treatment equipment products will vary depending on the control valve brand used.

Facts to Remember While Planning Your Installation:

- 1) All installation procedures **MUST** conform to local and state plumbing codes.
- 2) If lawn sprinkling, a swimming pool, or geothermal heating/cooling or water for other devices/activities are to be treated by the iron and manganese reduction system, a larger model **MUST** be selected to accommodate the higher flow rate plus the backwashing requirements of the iron and manganese reduction system. Consult your Dealer/Installer or your Dealer/Installer or our Customer Service Department at 1-800-222-7880. for alternative instructions if the pumping rate is insufficient.
- 3) Remember that the iron and manganese reduction system **INLET** is attached to the pipe that supplies water (i.e. runs to the pump) and the **OUTLET** is the line that runs toward the water heater.

CAUTION

To reduce the risk associated with property damage due to plugged water lines:

- Pay particular attention to correct orientation of control valve. Water flow should match arrow on control valve. The inlet and outlet of other water treatment equipment products will vary depending on the control valve brand used.

- 4) Before commencing the installation it is advisable to study the existing piping system and to determine the size, number and type of fittings required.

WARNING

To reduce the risk associated with a hazardous voltage:

- If the home electrical system requires use of the cold water system as an electrical safety ground, a jumper must be used to ensure a sufficient ground connection across the filter installation piping — refer installation to qualified personnel.

- 5) Sweep the floor to eliminate objects that could pierce the media tank.

SECTION 3: IMPORTANT INSTALLATION INSTRUCTIONS

Proper installation sequence of water conditioning equipment is very important. Refer to the following diagram for your particular water supply. Failure to follow installation, operation, and maintenance instructions may result in property damage due to leakage and will void warranty.

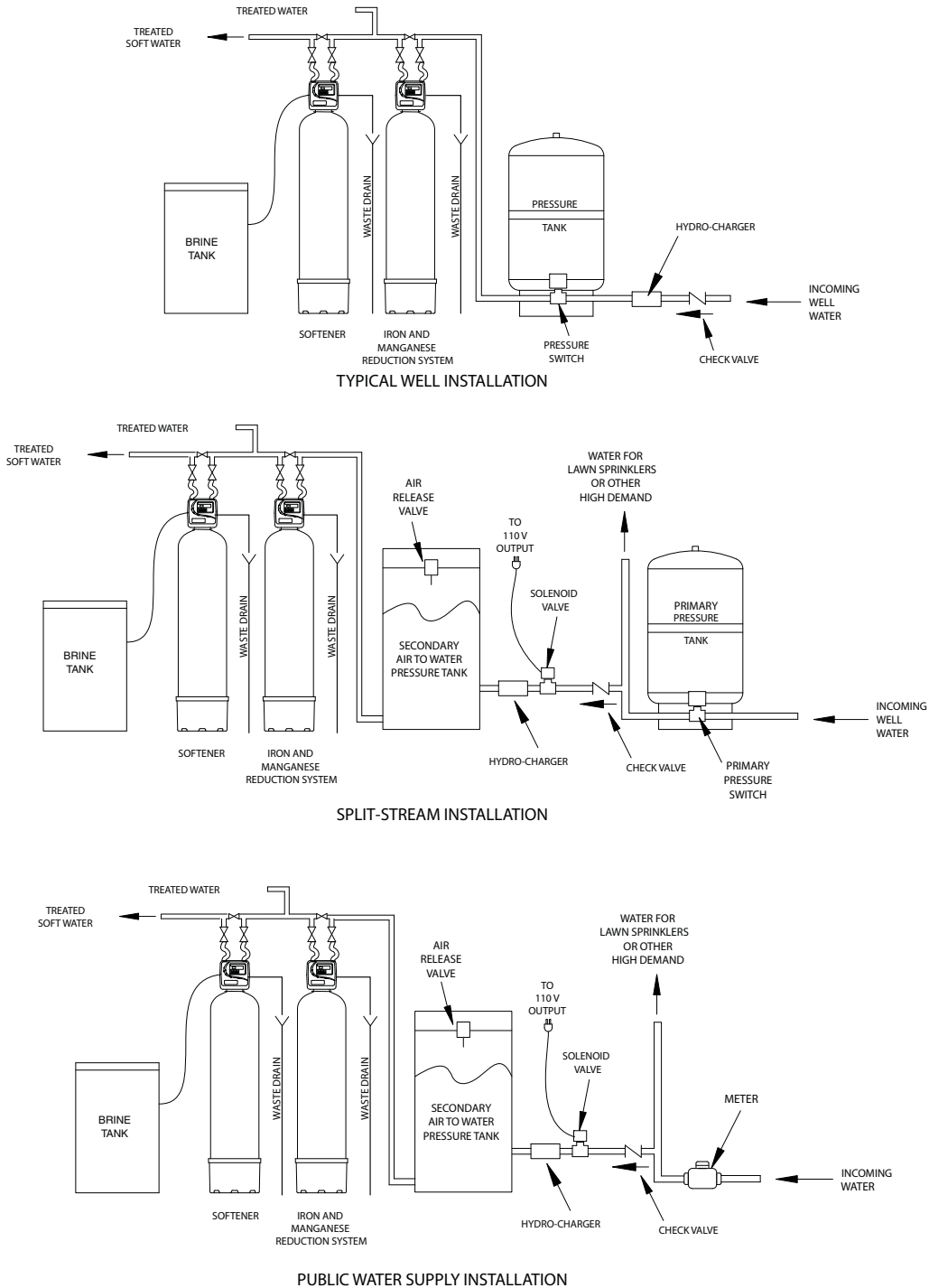

Figure 1

CAUTION

To reduce the risk associated with property damage due to water leakage:

- **Read and follow** Use instructions before installation and use of this water treatment system.
- Installation and use **MUST** comply with existing state or local plumbing codes.

To reduce the risk associated with property damage due to plugged water lines:

- Pay particular attention to correct orientation of control valve. Water flow should match arrow on control valve. The inlet and outlet of other water treatment equipment products will vary depending on the control valve brand used.

GRAVEL AND CHEM-FREE MEDIA SCHEDULE				
Unit Model Number	APIF100 Models (APIF100, APIF100DM, APIF100J, APIF100M, APIF100MDM, APIF100PT, APIF100PTDM, APIF100MPT, APIF100MPTDM, APIF100MJ)	APIF150 Models (APIF150, APIF150DM, APIF150J, APIF150M, APIF150MDM, APIF150PT, APIF150PTDM, APIF150MPT, APIF150MPTDM, APIF150MJ)	APIF200 Models (APIF200, APIF200DM, APIF200J, APIF200M, APIF200MDM, APIF200PT, APIF200PTDM, APIF200MPT, APIF200MPTDM, APIF200MJ)	APIF300 Models (APIF300, APIF300J, APIF300M, APIF300PT, APIF300MPT, APIF300MJ)
Filter Media	MC-10P	MC-10P MC-050P	MC-10P (2)	MC-10P (3)

NOTE: If you ordered an “M” model iron and manganese reduction system, the filter pack media would be designated by an M at the end of the part number i.e. MC-10MP.

To load the filter media into the media tank please use the follow steps. This is necessary to ensure that the distributor tube has not been pulled up when the control valve was removed from the top of the media tank.

Step 1

- a) Remove from the shipping carton the filter unit
- b) Carefully remove the control valve from the tank by rotating the valve head assembly to the left (counter-clockwise).
- c) Set all items aside for future use. Ensure that the following items have been shipped entirely with the unit to allow for proper and complete installation.
 - i. Control valve
 - ii. Media tank (also a reducing bushing and flanged adapter on APIF300)
 - iii. Bypass valve
 - iv. 1” Male NPT Connection Kit
 - v. Media (amount will vary by filter size)
 - vi. Distributor Tube
 - vii. Drain line assembly kit
 - viii. Parts bag
 - ix. Hydrocharger
 - x. Installation and Operating Instructions
 - xi. Loading funnel
 - xii. Centering Tool
- d) Remove the distributor tube in the tank, set aside and pour the gravel into a clean pail for later use.
- e) Reinsert the distributor tube into the tank and ensure the tube is centered in the tank; a dimple is in the center of the tank to help in doing so. Using the centering tool and cap, cover the distributor tube opening to prevent filter media and gravel from entering the distributor tube during the loading of the tank.
- f) Threaded Tank Models: APIF100, APIF100J, APIF100PT, APIF100MPT, APIF100MJ, APIF150, APIF150J, APIF150M, APIF150PT, APIF150MPT, APIF150MJ, APIF200, APIF200J, APIF200PT, APIF200MPT, APIF200MJ, APIF300, APIF300J, APIF300PT, APIF300MPT, APIF300MJ; Place the funnel provided, in the opening of the media tank to aid in loading the gravel and filter media. Pour the QC gravel into the tank slowly. While holding the distributor tube in place, shake the tank from side to side gently, to aid in leveling the QC gravel. Do not allow gravel to get under the basket of the distributor tube during the loading of gravel. If this happens, pour out the gravel and remove the distributor tube once again and reload gravel once again. Next locate the filter media and slowly pour into the tank. Again shake the tank from side to side to aid in leveling the media. Next, using a hose or clean pail, fill the tank with water to saturate the filter media and expel any air that may be present, remove the extension tube, cap and funnel, and save for future servicing.
- g) Dome Hold Tank Models: APIF100DM, APIF100PTDM, APIF100MDM, APIF100MPTDM, APIF150DM, APIF150PTDM, APIF150MDM, APIF150MPTDM, APIF200DM, APIF200PTDM, APIF200MDM, APIF200MPTDM;
Add media through fillport cap located on tank using funnel (See FILLING MEDIA TANK below). Fillport cap can be removed by turning a quarter turn counter clockwise.

⚠ CAUTION

To reduce the risk associated with skin, eye, and respiratory tract irritation from dust from filter media during installation:

- Gravel and several types of filter media may be used in this product, depending upon the application. During installation, dust may cause irritation to skin, eyes, and respiratory tract, and may affect lungs.
- Utilize a NIOSH-approved dust filter mask and appropriate eye protection when handling and pouring gravel and filter media.
- To request an MSDS relating to this product, call 203-238-8965 or go to www.3M.com, select country, and use the search engine to search MSDS. **For emergencies, call 800-364-3577 or 651-737-6501 (24 hours).**

Reinstall fillport cap by turning a quarter turn clockwise.

If bypass valve assembly is not factory pre-installed, attach using clips and screws.

Using a clean dry rag, wipe the opening of the media tank to remove any dust or residue from the opening to receive the control valve. Attach the valve head to the media tank by rotating the valve head assembly to the right (clockwise).

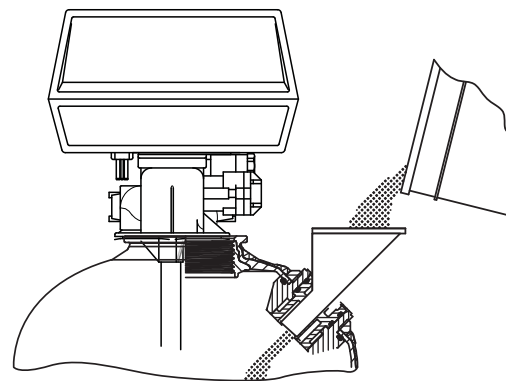

FILLING MEDIA TANK

Step 2

Shut off water at main supply. On a PRIVATE WELL SYSTEM turn off the power to the WELL PUMP and drain PRESSURE TANK. Make certain all water pressure has been relieved from water system by opening nearest faucet to drain water system. SHUT OFF FUEL SUPPLY TO WATER HEATER OR BOILER.

Step 3

Cut main supply line as required to fit hydro-charger in plumbing between well pump and pressure tank (hydro-charger may be installed in a vertical or horizontal position). The hydro-charger has been supplied with both 1" threaded and 1" barbed (insert) fittings to allow for installation with various types of piping materials. When using the threaded nipples, use thread tape only. When using barbed (insert) fittings, appropriate pipe clamps must be used. Once installed the quick release nipples allow the hydro-charger to be rotated, so the air draw adjustment screw is accessible for adjustment by a small bladed screwdriver. Allow at least 10 inches of straight run of 1" pipe on both INLET and OUTLET side of the hydro-charger. Refer to Figure 2 for correct assembly. The quick release nipples also act as a union to facilitate the hydro-charger removal, inspection and cleaning as needed. With an installation on PVC pipe and copper tubing it may require the addition of a plumbing union to aid in removal from the plumbing due to the rigidity of that type of material. Make certain the directional arrows on the hydro-charger point towards the pressure tank and the pressure control switch is located on the pressure tank side of hydro-charger as in Figure 1. Rapid cycling of pump may occur if the pressure control switch is located on well side. If a check valve is located between hydro-charger and pressure tank, it may prevent the hydro-charger from performing properly. Relocate to well side of hydro-charger.

Step 4

Turn back on the power to the well pump and pressurize the water lines to allow for adjustment of the hydro-charger. Check for leaks and adjust as necessary.

IMPORTANT NOTES

- Do not apply heat near hydro-charger, as damage may occur. On badly scaled, older plumbing systems, it may be advantageous to install a **WYE STRAINER** to help prevent plugging of the hydro-charger nozzle with scale or debris. **The use of a WYE STRAINER must precede the hydro-charger on the inlet side by a MINIMUM OF 10".**
- If existing water system includes a captive-air type pressure tank (bladder) and it is desirable to install an additional air to water type with an air release (not as a split steam type installation) install an air to water type pressure tank between the hydro-charger and the existing captive air type pressure tank.
- **Before proceeding with hydro-charger installed, re-verify adequate pumping rate pumping by following the procedure described in SECTION 2. After verification of adequate flow, depressurize system as described previously.**
- **If installation is to be split streamed prior to tank or is it a public water supply (see figure 1), or refer to special instructions on page 3-11.**

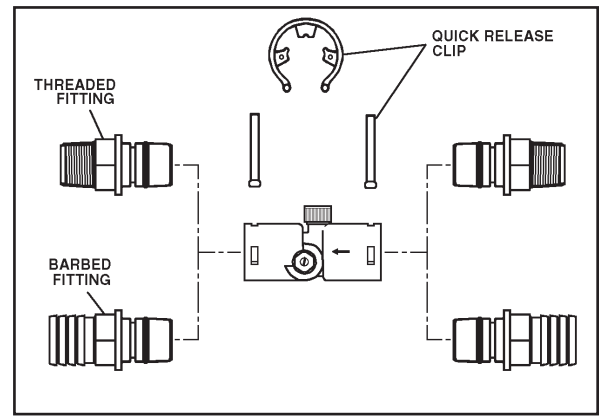

Figure 2: Hydro-Charger Installation

Step 5

Set hydro-charger by following the following steps:

- a) Open nearest faucet until well pump starts, then close faucet.
- b) Place a finger lightly over the SUCTION PORT (Figure 4). A slight suction should be detected for approximately ONE THIRD (1/3) of pumping cycle time. (Do not confuse with ONE THIRD (1/3) of pressure range).
- c) If suction is too short, increase by turning air adjustment screw (Figure 4), CLOCKWISE. To decrease duration, turn COUNTER-CLOCK WISE.
- d) Repeat steps (a) through (c) until proper setting is obtained. The optimum cycle time is 60 seconds or more, with an air draw of 20 seconds minimum. Position DRAIN LINE over drain and secure firmly. To prevent back-siphoning of sewer water, provide an air gap of at least 2 inches or 2 pipe diameters between end of drain hose and drain (Figure 6). Do not raise DRAIN LINE more than 10 ft. above floor.

IMPORTANT NOTE

When the duration of the suction is too long, the cold water may have a milky appearance caused by excess air in the water system. Correct this condition by reducing the duration of suction. This condition is commonly associated with bladder type pressure tanks. In extreme cases where elimination of excess air prevents system from performing satisfactorily, it may be necessary to install an air to water pressure tank with an air release valve.

Step 6

Turn off the electrical source to the water well pump or the close the water shut off valve on a municipal water supply to the dwelling once again. Depressurize the water system by opening the nearest faucet to drain water from the water system in order to allow the installation of the iron and manganese reduction system.

Step 7

Determine location and cut the water line on the supply side of the pressure tank as required to fit the plumbing to the control valve connection fittings. You may want to install a separate three valve bypass prior to the control valve in case the supplied bypass valve requires maintenance in order to provide undisturbed water use.

Step 8

Assemble and attach bypass valve to the control valve. See Figure 3 if needed. Next locate and assemble the 1" NPT connection fittings before attaching them to the bypass valve. Use the appropriate method of connection to ensure a permanent connection. Please refer to figure 5 to correctly assemble the connection fittings. Install the fitting into the bypass valve, attach the plumbing to the 1" NPT male connection fittings, hand tighten the fittings nuts only. Make certain the water enters inlet and discharges through the outlet side of the bypass valve. Arrows can be viewed on the bypass valve to confirm the correct flow path. At this time make certain the bypass valve is in the bypass position and leave in that position until instructed to place in the service position. Refer to Figure 3 for proper operation.

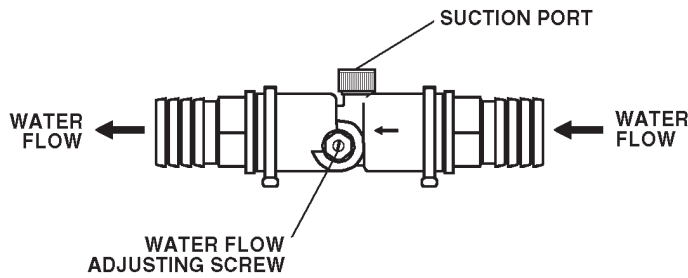

Figure 4

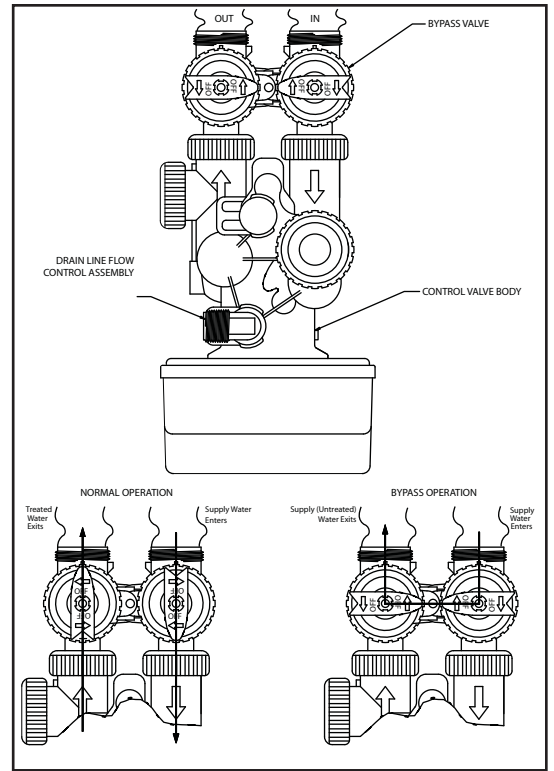

Figure 3

CAUTION

To reduce the risk associated with property damage due to water leakage:

- Do not use a torch or other high temperature sources near filter system, cartridges, plastic fittings or plastic plumbing;
- On plastic fittings, never use pipe sealant or pipe dope. Use PTFE thread tape only, pipe dope properties may deteriorate plastic;
- Take care when using pliers or pipe wrenches to tighten plastic fittings, as damage may occur if over tightening occurs.

Step 9

Fitting Installation Instructions

- 1) The installation fittings are designed to accommodate minor plumbing line and fittings.
- 2) Thread tape is the only type of thread sealant allowed to be used; the use of paste of any kind will void the factory warranty. Do not let the connection fittings support the plumbing, properly support the plumbing as required.
- 3) Slide the nut on first (closed and against the threads), then slip ring onto the fitting, ensuring it set correctly in groove, then the O-ring last. Use silicone lubricant to allow for easier insertion of parts into one another.
- 4) Hand tighten the nut only, the use of pliers or wrenches of any type will void the factory warranty and may cause damage to fittings and water will leak in your home or facility.

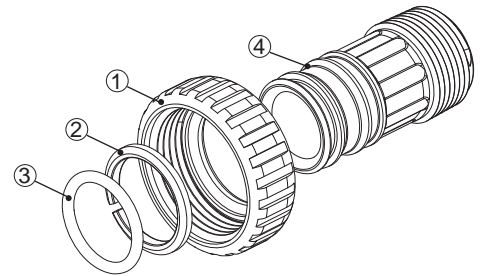

Figure 5

Use customer supplied fittings to adapt the drain line to the control valve. Support of the drain line is required to prevent damage to the drain line elbow which could lead to a water leak in the dwelling. Suitable drain line material can be Copper, PVC or CPVC pipe, PEX or PE tubing can be used to adapt to the 3/4 NPT threads on the drain elbow for long or high drain lines. Use only thread sealing tape to seal the threads, hand tighten the threaded joint. To utilize polyethylene tubing as a drain line, remove the supplied nut and find the insert that was shipped in the parts kit bag. Slide the nut over the polyethylene tubing and insert the sleeve into the tubing. Slide the end of the tubing into the elbow, using your hand thread the nut onto the elbow and hand tighten only. No thread tape is required to seal the threads with compression fittings.

CAUTION

To reduce the risk associated with property damage due to water leakage:

- Take care when using pliers or pipe wrenches to tighten plastic fittings, as damage may occur if over tightening occurs.

Typical examples of proper drain line diameters and lengths are:

1/2" ID up to 15 feet when discharge is lower than the inlet.

5/8" ID up to 15 feet when discharging is slightly higher than the inlet.

3/4" ID when drain is 25 feet away and not higher than 4 feet above control valve.

Avoid installing drain line overhead or using flexible vinyl tubing. Use of either may result in the filter not operating properly in reducing iron, manganese or turbidity. Some areas prohibit the use of flexible drain lines. Check with the local code officials prior to installation to ensure you conform to local, state and national plumbing codes.

Step 10

Position the DRAIN LINE over the waste drain pipe and secure firmly. To prevent back siphoning of sewer water or grey water, provide an air gap of at least two inches or 2 times the pipe diameters between the end of drain line tubing and waste drain (Figure 6). Do not raise the DRAIN LINE more than 10 feet above the floor. Check with local code officials to ensure you conform to local, state and national plumbing codes.

Step 11

Plug the control valve into a properly grounded 110 V, 60 Hz non switched electrical outlet. Check with your local code enforcement office to determine if it meets local codes.

Step 12

Set the time of day by referring to **Page 3-8 "How to Set Time of Day"**.

Step 13

Open the valve on the water supply as required to pressurize the water lines to the dwelling or fuel source. The power to the water heater or boiler needs to be established once water has been allowed to flow back into the device, if it was drained at any time during the installation. Turn back on the power or fuel source to either the water heater or boiler if it was drained at any time during the installation. Check for leaks on all connections before leaving the job site, correct as required.

Step 14

Manually initiate regeneration of the iron and manganese reduction system by referring to the **"How To Manually Initiate Immediate Regeneration"** section of Control Valve settings on Page 3-8.

Step 15

Once the valve is in the backwash position (C1 appears on the display) slowly open the inlet side of the bypass valve to allow water to flow into the tank. Water should start to flow into the drain. Allow for any air that might have been trapped to leave the filter and go to drain. This will be detected by changes in noise in the drain line or is visible in the semi-transparent tubing. Once the air is entirely gone slowly increase the water flow to drain by opening the inlet side of the bypass valve until fully open. Refer to **Figure 3** for correct positioning. At the end of C1 position the water should be clear. If not, allow the valve to complete the manual regeneration process and initiate once again. It is very important to allow the unit to purge all fines to the waste drain from the media in the tank prior to using the water. Once the flushing process has been completed you now can open the outlet side of the bypass valve to allow for filtered water to flow into the dwelling.

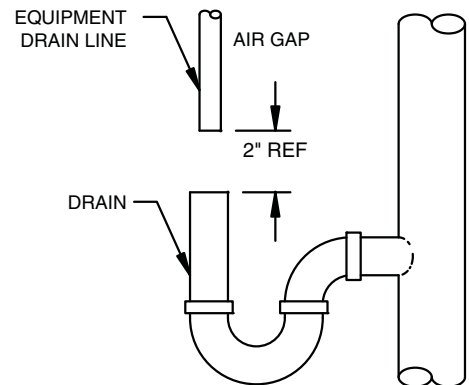

Figure 6: Drain

IMPORTANT NOTES

Due to the nature of the iron reduction media, on start up it sometimes requires 2 or 3 days for the iron and manganese reduction system to reduce Iron and Manganese below staining levels. Do not be alarmed if this occurs. During the initial start up and subsequent first couple automatic regeneration cycles, a small amount of fine white and beige media may be observed in the drain water and or drain area. This is normal and beneficial for the efficient operation of your iron and manganese reduction system.

Step 16

The frequency of backwash is factory preset at every 4 days. If the iron content is greater than 5 ppm, is red water or bacterial iron the unit should be washed more frequently. See tables to determine the frequency. Also if the water has tannin-lignin or hydrogen sulfide present, the filter should backwash every day. Refer to Section 4 for backwashing instructions and frequency.

BACKWASH FREQUENCY SCHEDULE

Models: APIF100, APIF100DM, APIF100J, APIF100M, APIF100MDM, APIF100PT, APIF100PTDM, APIF100MPT, APIF100MPTDM and APIF100MJ								
Persons in Family	IRON CONTENT - (PPM).							
	2	4	6	8	10	12	14	16
1	12	12	12	12	12	12	12	12
2	12	12	12	6	6	6	6	6
3	12	12	6	6	6	4	4	4
4	12	12	6	6	4	4	4	3
5	12	12	6	6	4	3	3	3
6	12	6	6	4	3	2	2	2

Models: APIF150, APIF150DM, APIF150J, APIF150M, APIF150MDM, APIF150PT, APIF150PTDM, APIF150MPT, APIF150MPTDM and APIF150MJ								
Persons in Family	IRON CONTENT - (PPM)							
	2	4	6	8	10	12	14	16
1	12	12	12	12	12	12	12	12
2	12	12	12	12	12	12	6	6
3	12	12	12	12	6	6	6	4
4	12	12	12	6	6	6	4	4
5	12	12	12	6	6	4	4	3
6	12	12	12	6	4	4	4	3
7	6	6	4	4	4	3	2	2
8	6	4	4	4	3	2	2	2

Models: APIF200, APIF200DM, APIF200J, APIF200M, APIF200MDM, APIF200PT, APIF200PTDM, APIF200MPT, APIF200MPTDM and APIF200MJ

Persons in Family	IRON CONTENT - (PPM) The total amount of iron should not exceed 15 ppm as this is the upper limit of iron we recommend this product to be placed on.											
	5	10	12	14	16	18	20	22	24	26	28	30
1	12	12	12	12	12	12	12	12	12	12	12	12
2	12	12	12	12	12	12	12	6	6	6	6	6
3	12	12	12	6	6	6	6	6	6	6	4	4
4	12	12	6	6	6	6	6	4	4	4	4	4
5	12	6	6	6	4	4	4	4	4	3	3	3
6	12	6	6	4	4	4	4	3	3	3	2	2
7	12	6	4	4	3	3	3	3	2	2	2	2
8	12	6	4	4	3	3	3	2	2	2	2	2
9	6	4	4	3	3	3	2	2	2	2	1	1
10	6	4	3	3	3	2	2	2	2	1	1	1

Models: APIF300, APIF300J, APIF300M, APIF300PT, APIF300MPT, and APIF300MJ

Persons in Family	IRON CONTENT - (PPM) The total amount of iron should not exceed 15 ppm as this is the upper limit of iron we recommend this product to be placed on.											
	10	12	14	16	18	20	22	24	26	28	30	32
1	12	12	12	12	12	12	12	12	12	12	12	12
2	12	12	12	12	12	12	12	12	12	12	12	6
3	12	12	12	12	6	12	6	6	6	6	6	6
4	12	12	12	6	6	6	6	6	6	6	6	4
5	12	12	6	6	6	6	6	6	4	4	4	4
6	12	6	6	6	4	6	4	4	4	4	3	3
7	6	6	6	6	4	4	4	4	6	3	3	3
8	6	6	6	4	4	4	4	3	3	3	3	2
9	6	6	4	4	4	4	3	3	3	2	2	2
10	6	6	4	4	4	3	3	3	2	2	2	2

Step 17

The installation of your iron and manganese reduction system is now complete. If your water system installation is something other than a private well system, please familiarize yourself with the **SPECIAL INSTRUCTIONS FOR SPLIT-STREAM AND PUBLIC WATER SUPPLY TYPE INSTALLATIONS** on page 3-11.

HOW TO SET TIME OF DAY

STEP 1



Step 1) Press SET

STEP 2



Time
PM
Days To
Regen

Step 2)

Use ▲ and ▼ to adjust the current time hour. Time display will be 12 hour with PM indicator with 60 Hz line frequency detection on power-up. Time display will be 24 hour without the PM indicator with 50 Hz line frequency on power-up. Press SET and proceed to step 3.

STEP 3



Time
PM
Days To
Regen

Step 3)

Use ▲ and ▼ to adjust the current time minutes. Press SET to exit Set Time of Day.

Power Loss



Time
PM
Days To
Regen

Power Loss

If power is lost for more than 8 hours, the current time of day will need to be reset. If the system is in the middle of regeneration upon power loss, the control will continue regeneration at the point of interruption when power is restored.

Error Message

Contact our technical service department at 800-222-7880 for assistance if the display shows "E1," "E2," "E3" or "E4." These messages are indications the valve did not function properly.

HOW TO MANUALLY INITIATE IMMEDIATE REGENERATION

If a system needs to be regenerated before the next scheduled time, manual regeneration can be initiated. This may be necessary during times of heavy water usage, including house guests or heavy laundry days.

To initiate an immediate manual regeneration, press ▲ and ▼ simultaneously for three seconds. This request cannot be cancelled.

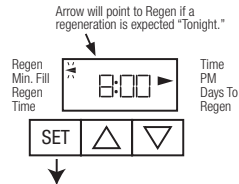

HOW TO MANUALLY INITIATE DELAYED REGENERATION

To initiate a manual regeneration at the preset delay time, press ▲ and ▼ simultaneously. Release. An arrow will point to REGEN if regeneration is expected "tonight." To cancel, press ▲ and ▼ simultaneously. Release.

TO SET TIME OF REGENERATION AND DAYS BETWEEN REGENERATION

STEP 1

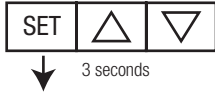

Follow these steps for initial set-up of or to make adjustments to the time of regeneration and/or the days between regenerations. The number of days between regenerations may need to be varied based on usage and water conditions.

STEP 2

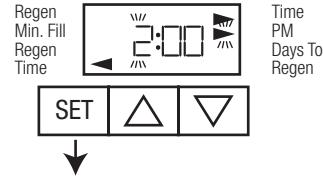

STEP 1

Press "SET" and ▲ for approximately 3 seconds. (This step will not appear if the 7-day clock option is selected.)

STEP 2

Set Regeneration Time Hour. Set the time for regeneration to start using the ▲ and ▼ arrows. Press SET to go to the next step.

STEP 3

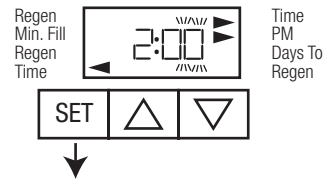

STEP 3

Set Regeneration Time Minutes using the ▲ and ▼ arrows. Press SET to go to the next step.

STEP 4

Set Number of Days between regeneration cycles using the ▲ and ▼ arrows.

STEP 5

Press SET to complete and return to normal operation.

STEP 4

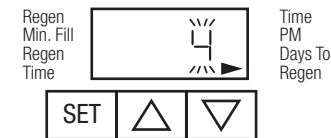

HOW TO CHANGE THE REGENERATION PROGRAM SETTINGS

STEP 1 - Press and hold SET HOUR and ▲ buttons simultaneously until the display begins flashing (usually about three (3) seconds).

STEP 2 - Press and hold SET HOUR and ▲ buttons simultaneously until the display begins flashing (usually about three (3) seconds).

STEP 3 - Press the SET HOUR to change the display to P8 or P9.

STEP 4 - Press the SET HOUR button five (5) times to return to the display mode. The time of day should be in the display.

Control Valve Function and Cycles of Operation

The AC adapter comes with a 15 foot power cord that is designed for use with the control valve. **The AC adapter is for dry location use only.** If the power goes out, only the time of day needs to be reset. All other settings are permanently stored in the non-volatile memory.

The following chart shows the time for the backwash and rapid rinse cycles for the three available programming options.

Regeneration Cycles and Times for Different Programs

Program Number	Length of Cycle Times (Minutes)	
	BACKWASH (C1)	RAPID RINSE (C4)
P7	6	4
P8	10	6
P9	14	8

Note: Your iron and manganese reduction system is factory preset to program number P7, changing the setting to P8 or P9 is rarely needed. But if a change is desired, please refer to **“How to Change the Regeneration Program Settings”** on page 3-9.

USER DISPLAYS

General Operation

When operating, the system will either display the current time of day or the days remaining until the next regeneration. Use ▲ or ▼ to toggle between the two displays. If the remaining days is at 1, the system will regenerate at the preset time.

An arrow will appear pointing to REGEN when the system calls for regeneration.

Regeneration Mode

When the system is regenerating, untreated water will be used. Therefore, systems are typically set to regenerate during times of low water usage—such as when the household is asleep.

During regeneration, the arrow will point to REGEN and the display will change to Regeneration Cycle Display, indicating the time remaining. The system automatically runs through the steps of regeneration; upon completion, treated water is ready for use.

Arrow will point to Regen if a regeneration is expected "Tonight."

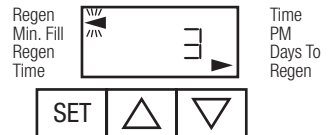
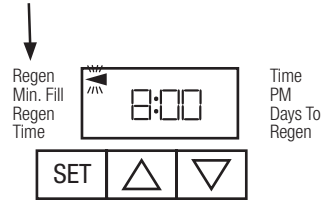

CAUTION

To reduce the risk associated with property damage due to water leakage:

- Installation and use **MUST** comply with existing state or local plumbing codes;

Special Instructions for Split-Stream and Public Water Supply Type Installations:

For a split-stream type installation, a secondary air-to-water pressure tank must be installed as in Figure 1. On a public water supply type installation, a pressure tank must be installed as in Figure 1. It is recommended in both applications to use a standard air-to-water type pressure tank with a deep well air volume control (air release valve). The pressure tank should be of same capacity as would normally be installed if the water system were a standard private well. Also note, both applications require a 1" normally-closed solenoid valve. Follow standard installation procedures above with the following additions and modifications.

- 1) Install a secondary air-to-water pressure tank in Figure 1 as indicated by the appropriate diagram.
- 2) Install a normally-closed solenoid valve, 110, 60Hz after water meter and after a line split for untreated water (if there is one). The use of a check valve in the water line is highly recommended.
- 3) On both types of installation, install the hydro-charger between the normally-closed solenoid valve and pressure tank (secondary air-to-water pressure tank on split-stream type installation) maintaining a minimum of 10" on both inlet and outlet of hydrocharger.
- 4) Install the pressure switch after hydro-charger and wire it to the secondary pressure switch on the split-stream. Power for the secondary pressure switch should be provided by a separate 110V, 60 Hz source for the split stream installation. For public water supply installation, power for the pressure switch should also be provided by a separate 110V, 60 Hz power source. Set the high pressure on the pressure switch (which controls opening and closing of solenoid valve) 2 to 3 psi lower than low pressure on primary pressure switch. Example: if the primary pressure switch is set at 40/60 psi, set the secondary pressure switch at 20/38 psi. For public water supply type installations, contact your local water department or plant operator and ask what the normal low system pressure is. Set the high pressure on the pressure switch 2 to 3 psi lower than this figure.

IMPORTANT NOTE

Failure to set **PRESSURE SWITCH** as described above will **NOT** allow proper closing of **SOLENOID VALVE** during periods of low system pressure. Improper function of **SOLENOID VALVE** will cause total failure of system.

Special Service Instructions:

Under normal circumstances removal of valve should never be required. However, if it must be removed, it can be done by rotating the valve head assembly to the left (counter-clockwise). Pressure should be relieved before attempting any disassembly. Upon reassembly, all O-rings should be lubricated with silicone grease.

BYPASS VALVE OPERATION

NORMAL OPERATION

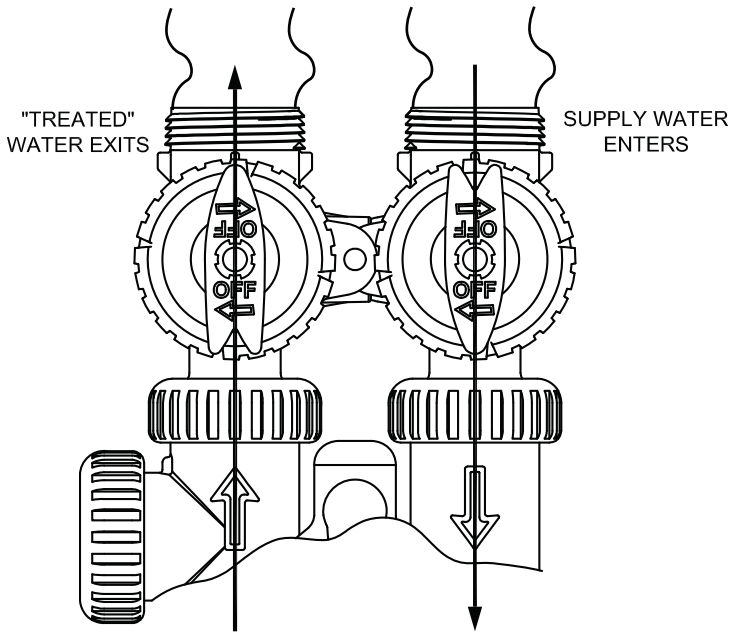

Figure 7

BYPASS OPERATION

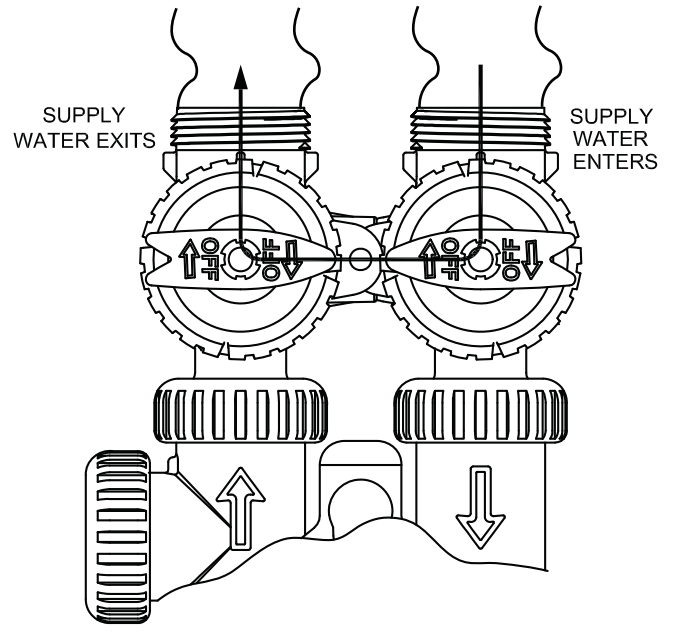

Figure 8

DIAGNOSTIC MODE

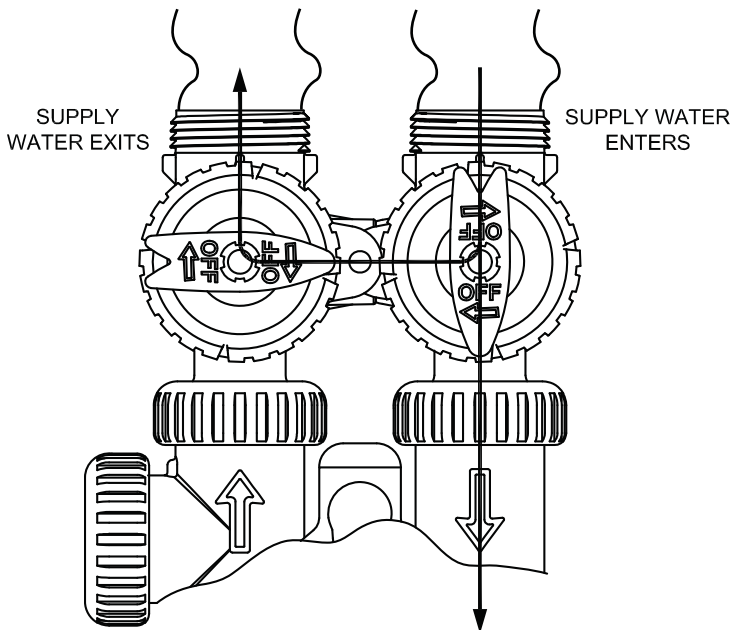

Figure 9

SHUT OFF MODE

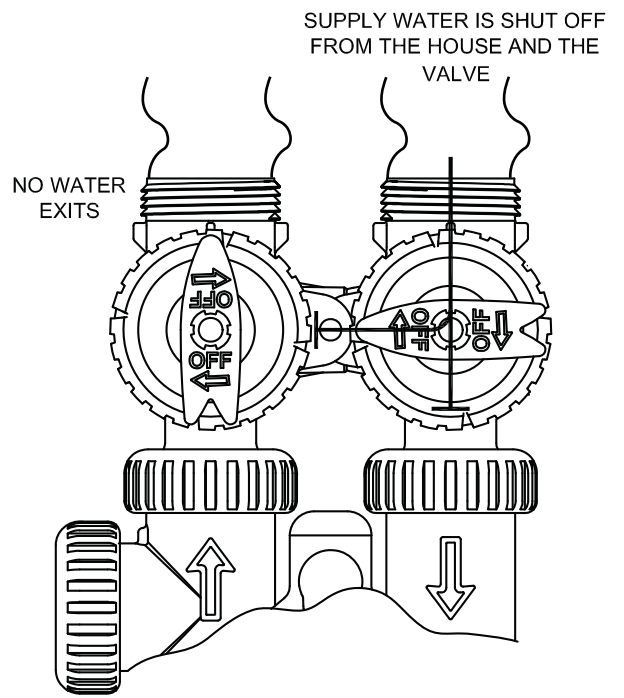

Figure 10

Section 4: BACKWASHING INSTRUCTIONS

Periodic regeneration of the iron and manganese reduction system bed is required to flush out the entrapped iron that has accumulated. This procedure is performed automatically at 1:00 a.m. for a period of approximately 10 minutes and will not interfere with a softener regeneration, which is usually set for 2:00 a.m.

TO SET BACKWASH FREQUENCY FOR NORMAL HOUSEHOLD APPLICATIONS:

To determine and set Backwash Frequency, follow these instructions:

- 1) Select Backwash Frequency Schedule corresponding to your model (page 3-6 and 3-7).
- 2) Locate box intersected by number of persons in your family and iron content of water (if iron concentration is between two numbers in Schedule, use higher number.)
- 3) Number in box represents number of days, between regenerations. Refer to How to Set Time of Regeneration and Days Between Regeneration on page 3-9.

Example: You have model APIF100, 4 people in family, and 8 ppm iron. Refer to Schedule for model APIF100 and locate box intersected by 4 in family and 8 ppm iron. The figure indicates 6 as the the number of days between each regeneration period.

IMPORTANT NOTE

The Backwashing Frequency Schedules are based on average water consumption rates and are merely guides. They are NOT intended to be used if water is used by outside spigots, a swimming pool, geothermal heat pump, or other high water usage devices or activities.

Section 5: TROUBLESHOOTING - CONTROL VALVE

Problem	Possible Cause	Solution
1. Timer does not display time of day	a. AC adapter unplugged	a. Connect power
	b. No electric power at outlet	b. Repair outlet or use working outlet
	c. Damaged AC adapter	c. Replace C Adapter
	d. Damaged PC board	d. Replace PC board
2. Timer does not display correct time of day	a. Switched outlet	a. Use an unswitched outlet
	b. Time of day not set correctly	b. Reset time of day
3. Control Valve regeneration at wrong time of day	a. Power outages	a. Reset control valve to correct time of day
	b. Time of day not set correctly	b. Reset to correct time of day
	c. Time of regeneration incorrect	c. Reset regeneration time
4. Error followed by a code number Error code E1- Unable to recognize start of regeneration Error code E2- Unexpected stall Error code E3- Motor ran too long. Timed out trying to reach next cycle position If other codes appear contact factory	a. Control valve has just been serviced	a. Press SET HOUR and DOWN for 3 seconds or unplug power source jack (black wire) from the circuit board and plug back in to reset control valve
	b. Foreign matter is lodged in control valve	b. Check piston and spacer stack assembly for foreign matter
	c. High drive forces on piston	c. Replace piston(s) and spacer stack assembly
	d. Control valve piston not in home position	d. Press SET HOUR and DOWN for 3 seconds or unplug power source jack (black wire) from the circuit board and plug back in to reset control valve.
	e. Motor not inserted fully to engage pinion, motor wires broken or disconnected, motor not working properly.	e. Check motor and wiring. Replace motor if necessary
	f. Drive gear label dirty or damaged, missing or broken gear	f. Replace or clean drive gear
	g. Drive bracket incorrectly aligned to drive bracket	g. Reseat drive bracket properly
	h. PC board incorrectly aligned to drive bracket	h. Replace PC board
	i. PC board incorrectly aligned to drive bracket	i. Ensure PC board is correctly snapped on to drive bracket
5. Control valve stalled in regeneration	a. Motor not operating	a. Replace motor
	b. No electric power at outlet	b. Repair outlet or use working outlet
	c. Damaged AC adapter	c. Replace AC adapter
	d. Damaged PC board	d. Replace PC board
	e. Broken drive gear or drive cap assembly	e. Replace drive gear or drive cap assembly
	f. Broken piston retainer	f. Replace piston retainer
	g. Broken main or regenerant piston	g. Replace main or regenerant piston
6. Control valve does not regenerate automatically when UP and DOWN buttons are depressed and held.	a. AC adapter unplugged	a. Connect AC adapter
	b. No electric power at outlet	b. Repair outlet or use working outlet
	c. Broken drive gear or drive cap assembly	c. Replace drive gear or drive cap assembly
	d. Damaged PC board	d. Replace PC board
7. Control valve does not regenerate automatically, but does when UP and DOWN buttons are depressed and held	a. Damaged PC board	a. Replace PC board
	b. Set-up error	b. Check control valve set-up procedure

Section 5: TROUBLESHOOTING - FILTER UNIT

Problem	Possible Cause	Solution
1. Water CLEAR when drawn, turns RED upon standing (stain producing)	a. Insufficient air-draw by hydro-charger.	a. Check hydro-charger adjustment. If unable to adjust for long enough draw, check pumping rate.
	b. Bypass open or leaking	b. Close bypass valve and/or repair as necessary.
	c. Filter bed overloaded with precipitated iron due to insufficient backwash, or failure to backwash due to malfunction of control timer or unplugged control valve power cord.	c. Upon correction of problem (increase backwash frequency if problem determined to be insufficient frequency), manually backwash until backwash water starts to clear (in more severe iron fouling cases, filter bed may need chemical cleaning - contact dealer).
	d. Presence of manganese or tannins.	d. Recheck water analysis
	e. Flow rate excessive for model.	e. Reread Sec. 2, FACTS TO REMEMBER WHILE PLANNING YOUR INSTALLATION.
	f. Check-valve located between Hydro Charger and pressure tank, disrupting water flow.	f. Relocate check-valve.
	g. Pumping cycle too short, limiting residence time in pressure tank (may be water-logged).	g. Correct condition.
	h. pH of treated water too low (should be 7.0 or higher; with manganese, pH must be 8.2).	h. Replenish pH Plus component in media (contact dealer).
2. Water RED when drawn from tap	a. Filter bed overloaded with precipitated iron due to insufficient backwash flow rate.	a 1. Recheck well pumping rate and repair or replace as required. 2. Check for obstructions or kink in drain line. 3. Check for improper drain line flow controller (see specs.) Upon correction of this problem, if manually backwashing does not clear bed of iron, filter bed may need chemical cleaning - contact dealer.
	b. Filter bed over loaded with precipitated iron due to insufficient backwash, or failure to backwash due to malfunction of control timer or unplugged control valve power cord.	b. Upon correction of problem (increase backwash frequency if problem determined to be insufficient frequency), manually backwash until backwash water starts to clear (in more severe iron-fouling cases, filter bed may need chemical cleaning - contact dealer).
	c. Hydro-charger drawing too much air, causing early precipitation of iron.	c. Reduce hydro-charger air-draw.
	d. Hydro-charger installed too far from pressure tank or pressure tank located too far from media tank causing iron to precipitate before media tank.	d. Relocate to a location closer to filter inlet.
	e. Solenoid valve (SPLIT-STREAM or PUBLIC WATER SUPPLY type installation) malfunction or inadequate supply system pressure/flow rate.	e. Repair or replace solenoid valve and verify adequate supply system pressure and flow rate.
3. Excessive pressure loss through filter	a. Filter bed overloaded with precipitated iron.	a. Refer to Section 2 above.
	b. Control inlet/outlet valve(s) not fully open.	b. Open as necessary.
	c. Sand, silt or mud collecting in filter bed.	c. Check well for these conditions.
	d. Filter bed not properly "classified."	d. Manually backwash to reclassify.
	e. "Cementing" or "channeling" of filter media.	e. Prod (stir) filter bed to break up hardened layer. Increase backwash frequency to prevent reoccurrence.
4. "Milky" or "bubbly" water (Appears to contain small bubbles)	a. Excess hydro-charger air-draw.	a. Check adjustment for duration of draw in excess of one-third pumping cycle (see Sec.3, Step 10).
	b. Excess gases in water (carbon dioxide, hydrogen sulfide, methane).	b. May require draining of water system or installation of air-relief control on the fill port cap of valve adapter base, (contact dealer).

Section 6: VALVE SPECIFICATION AND OPERATING DATA

Maximum Service Flow Rate: Includes Bypass Valve	27 gpm (102.2 lpm) @ 15 psig (103 kPa) drop			
Maximum Backwash Flow Rate: Includes Bypass Valve	27 gpm (102.2 lpm) @ 15 psig (103 kPa) drop			
Minimum/Maximum Operating Pressure:	20 psi (138 kPa) - 125 psi (862 kPa)			
Minimum/Maximum Operating Temperature:	40°F (4.4°C) - 110°F (43.3° C)			
AC Adapter: Supply Voltage Supply Frequency Output Voltage Output Current	U.S.			
	120 V. AC			
	60 Hz			
	12 V. AC 500 mA			
Drain Line Flow Control	Unit Size	Number on Drain Line Flow Control	Backwash Flow Rate (gpm)	Backwash Flow Rate (lpm)
	1.0 ft ³	053	5.3	20.1
	1.5 ft ³	053	5.3	20.1
	2.0 ft ³	075	7.5	28.4
	3.0 ft ³	100	10.0	37.9
Inlet/Outlet Tube Opening	(a) 1" Universal Elbow (b) 1" Straight brass sweat fitting (c) 1" Plastic male NPT fitting			
Distributor Tube Opening	1.05" OD (3/4 NPS)			
Tank Thread	2 1/2" - 8 NPSM to Flanged Adapter			
Control Valve Weight	4.5 lbs. (2.0 kg)			
PC Board Memory	Nonvolatile EEPROM (electronic erasable programmable read only memory)			

Note: After completing any valve maintenance involving the drive assembly or the drive cap assembly and pistons, unplug the power source from the jack on the printed circuit board (black wire) and plug back in. This resets the electronics and establishes the service piston position.

Section 6: SPECIFICATION AND OPERATING DATA

ITEM	APIF100 APIF100DM APIF100J APIF100M APIF100MDM APIF100PT APIF100PTDM APIF100MPT APIF100MPTDM APIF100MJ	APIF150 APIF150DM APIF150J APIF150M APIF150MDM APIF150PT APIF150PTDM APIF150MPT APIF150MPTDM APIF150MJ	APIF200 APIF200DM APIF200J APIF200M APIF200MDM APIF200PT APIF200PTDM APIF200MPT APIF200MPTDM APIF200MJ	APIF300 APIF300J APIF300M APIF300PT APIF300MPT APIF300MJ
Media Volume, cu. ft. (cu. mtr.) (Note 1):	1.0 (0.03)	1.5 (0.04)	2.0 (0.06)	3.0 (0.08)
Gravel Underbed, lbs. (kg)	13 (5.9)	13 (5.9)	18 (8.2)	26 (11.8)
Nominal Capacity, ppm-gal.	30,000	45,000	60,000	90,000
Operating Service Flow Rate, gpm (lpm) (Note 2):	6 (22.7)	7 (26.5)	9 (34.1)	12 (45.4)
Pressure Loss @ Service Flow Rate, psi (kPa)	5 (34.5)	7 (48.2)	8 (55.1)	10 (68.9)
Backwash Flow Rate, gpm (lpm) Note 3	5.3 (20.1)	5.3 (20.1)	7.5 (28.4)	10 (37.9)
Service Pipe Size, in. (cm) (Note 4)	1 (2.5)	1 (2.5)	1 (2.5)	1 (2.5)
Media tank Diameter x Height, in. (cm)	10 x 44 (26 x 112)	10 x 54 (26 x 137)	12 x 54 (30 x 137)	14 x 65 (36 x 165)
Minimum Space Required, in. (cm):				
Width	12 (30)	12 (30)	12 (30)	13 (33)
Depth (w/Bypass)	16 (41)	16 (41)	16 (41)	16 (41)
Height	53 (135)	63 (160)	63 (160)	74 (188)
Approximate Shipping Weight, lbs. (kg)	143 (64.9)	186 (84.4)	257 (116.6)	353 (160.2)
Maximum Operating Temperature 110°F (43.3°C); Electrical requirements 110V/60Hz; Operating Pressure 20 -125 psi (138-861 kPa). Specifications subject to change without notice.				

IMPORTANT NOTE

- 1) Replenishment of pH adjusting component of media may be required periodically, the frequency of which is dependent on raw water pH, manganese concentration and water consumption rate. Consult dealer for more information.
- 2) For satisfactory performance, indicated durations should not be exceeded. Flow rates specified are adequate for normal residential applications. Do not use Service or Peak flow rates when sizing commercial applications or if treated water is to supply a geothermal heat pump, swimming pool, etc. (contact dealer before selecting equipment). Service flow rates have been tested against NSF Standard 42 and have a rated pressure drop of less than 10 psi.
- 3) For system to operate properly, pumping rate of well pump MUST be sufficient to backwash unit at rate specified.

Section 6: COMPONENT PARTS LIST

Ref. No.	Description	APIF100 APIF100DM APIF100J APIF100M APIF100MDM APIF100PT APIF100PTDM APIF100MPT APIF100MPTDM APIF100MJ	APIF150 APIF150DM APIF150J APIF150M APIF150MDM APIF150PT APIF150PTDM APIF150MPT APIF150MPTDM APIF150MJ	APIF200 APIF200DM APIF200J APIF200M APIF200MDM APIF200PT APIF200PTDM APIF200MPT APIF200MPTDM APIF200MJ	APIF300 APIF300J APIF300M APIF300PT APIF300MPT APIF300MJ
1	Control Valve, Complete, Less Bypass Valve	W217530-003-0N	W217530-003-0N	W217750-003-0N	W217000-003-0N
1a	O-ring (Included with Item #1)	V3180	V3180	V3180	V3180
2	Bypass Valve	V3006	V3006	V3006	V3006
3	Standard Media Tank w/Base	6236001-1044	6236001-1054	6236001-1252	6236001-1465
3a	Dome Hole Media Tank w/Base	6238601-1044	6238601-1054	6238601-1252	n/a
4	Distributor Tube	6236435	6236437	6236436	6236438
5	Filter Media Standard Models Manganese Models (M)	MC050P (2) MC-050MP	MC-075P (X2) MC-075MP (X2)	MC-050P (4) MC-050MP	MC050P (6) MC-050MP (6)
6	Gravel Underbed	QC-15P	QC-15P	QC-18P	QC-25P
7	Hydro-charger, Complete	HC10	HC10	HC10	HC10
8	Quick Release Clip	QRC20	QRC20	QRC20	QRC20
9	Air Check Cap	HC10-2	HC10-2	HC10-2	HC10-2
10	Air Check	HC10-10	HC10-10	HC10-10	HC10-10
11	O-ring; Bypass Screw	HC10-4	HC10-4	HC10-4	HC10-4
12	Bypass Screw	HC10-5	HC10-5	HC10-5	HC10-5
13	Screw Retainer	HC10-6	HC10-6	HC10-6	HC10-6
14	Nipple; 1" NPT (Qty 2, Includes Items #12 & 20)	PKNPL100	PKNPL100	PKNPL100	PKNPL100
15	Nipple; 1" Barbed (Qty 2, Includes Items #12 & 20)	PKNPL100-BARB	PKNPL100-BARB	PKNPL100-BARB	PKNPL100-BARB
16	O-ring	ORG-214	ORG-214	ORG-214	ORG-214
17	Nipple Kit (Includes Items #12, 18, 19, & 20)	IKIT-BARB	IKIT-BARB	IKIT-BARB	IKIT-BARB
22	Repair Kit (Includes Items #14 & 15)	HC10-RK	HC10-RK	HC10-RK	HC10-RK

Items Not Shown	
Description of Item	Part Number
Wrench	V3193-01
Vertical Bypass Adapter	V3191-01
Standard Funnel	U1006
Dome Hole Funnel	6238731
Tube Extension Device and Cap	CENTERTOOL
1" Plumbing Connection Fitting - Straight Male NPT Fitting - Straight Brass Sweat Connection	V3007-04 V3007-02

* see assembly drawings for individual components.

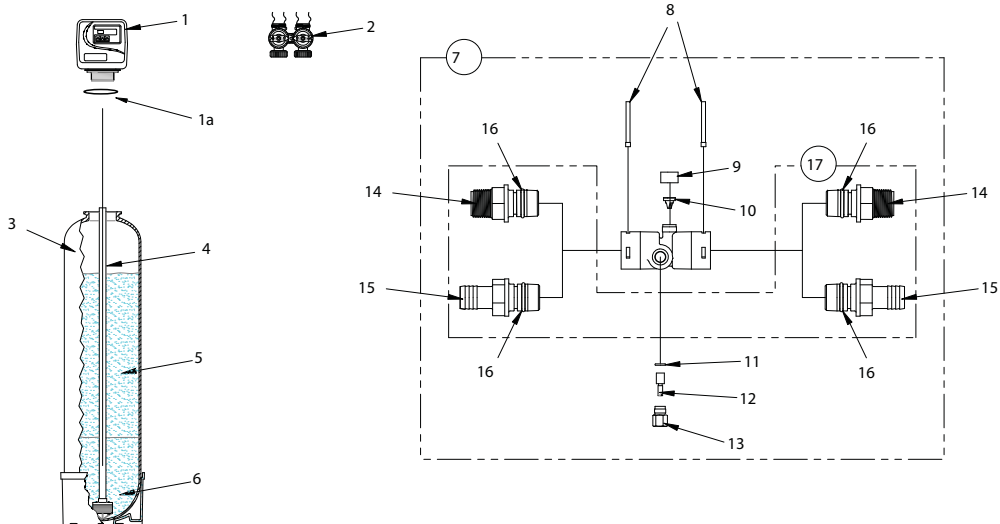

Section 6: COMPONENTS ASSEMBLIES

IRON AND MANGANESE REDUCTION SYSTEM ASSEMBLIES AND COMPONENTS DRIVE CAP ASSEMBLY, DOWNFLOW PISTON, AND SPACE STACK ASSEMBLIES

Reference No.	Part No.	Description	Quantity
1	V3005	Spacer Stack Assembly	1
2	V3004	Drive Cap Assembly	1
3	V3178	Drive Back Plate	1
4	V3001	Piston Downflow Assembly	1
6	V3135	O-ring 228	1
7	V3180	O-ring 337	1
8	V3105	O-ring 215 Pilot Tube	1
NOT SHOWN	V3001	Downflow body Assembly	1

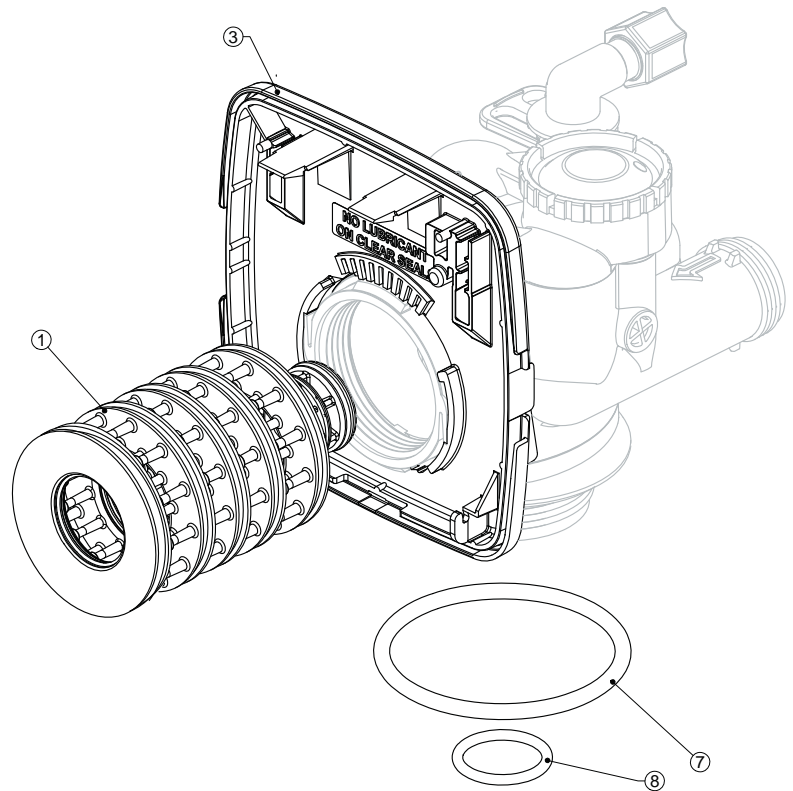
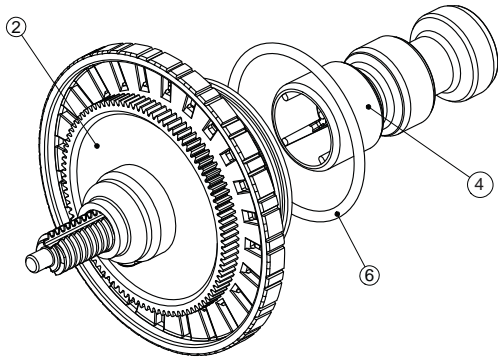

Section 6: FRONT COVER AND DRIVE ASSEMBLY

Reference No.	Part No.	Description	Quantity
1	V3175TC-01	Time Clock Front Cover Assembly	1
2	V3107-01	Motor	1
3	V3106-01	Drive Bracket & Spring Clip	1
4	V3108TC	Time Clock PC Board	1
5	V3110	Drive Gear 12 x 36	1
6	V3109	Time Clock Cover	1
	V3002TC	Time Clock Drive Assembly	1
NOT SHOWN	V3186	AC Adapter 110V - 12V	1

Drawing number parts 2 through 6 may be purchased as a complete assembly, part V3202.

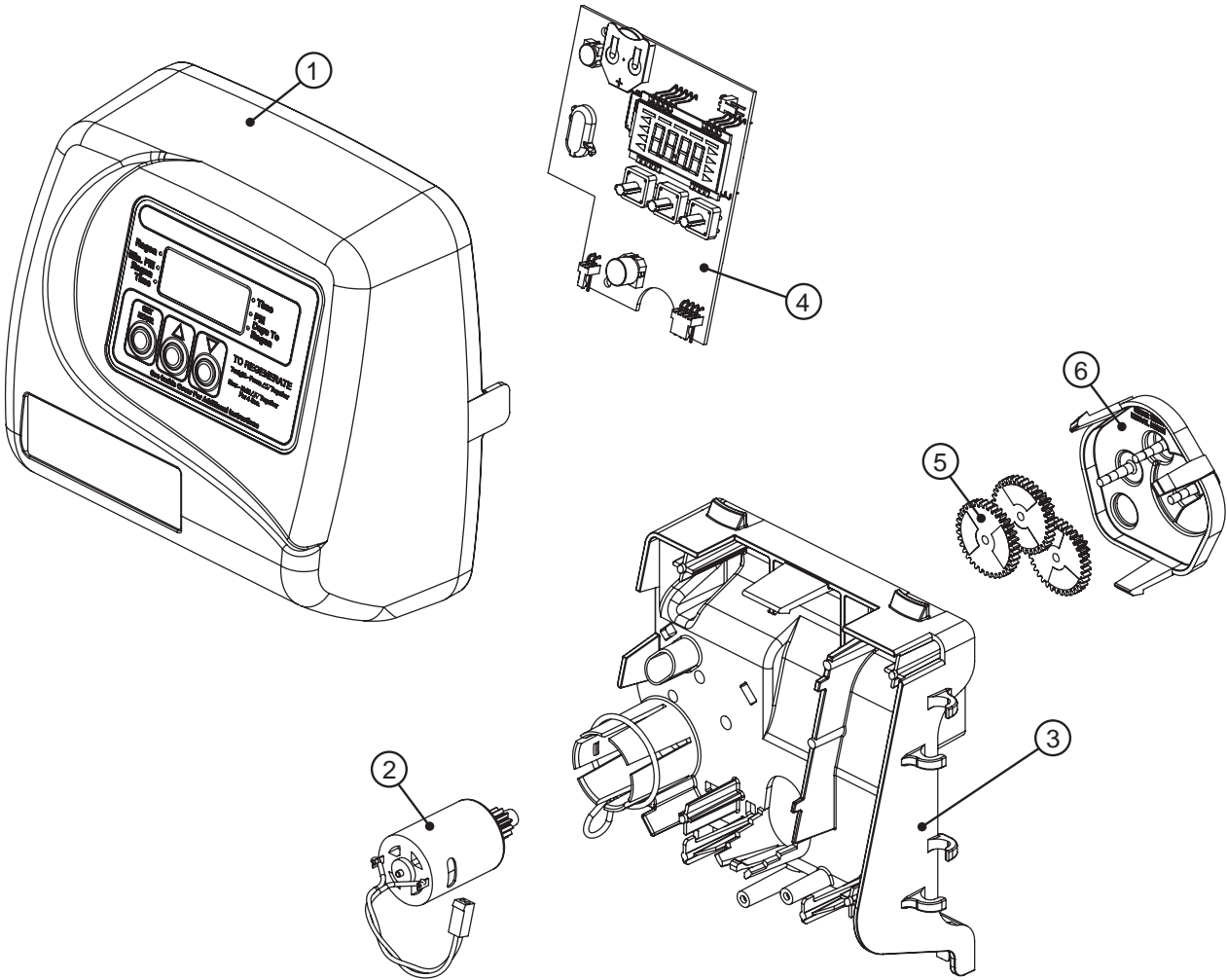

Section 6: QUICK CONNECT BYPASS Part Number V3006

Reference No.	Part No.	Description	Quantity
1	V3151	Nut 1" Quick Connect	2
2	V3150	Split Ring	2
3	V3105	O-ring	2

Not Shown Part# V3191-01 Vertical Bypass Adapter

V3151	1" Quick Connect Nut	2
V3150	Split Ring	2
V3105	O-ring 215	2
V3191	Vertical Bypass Adapter	1

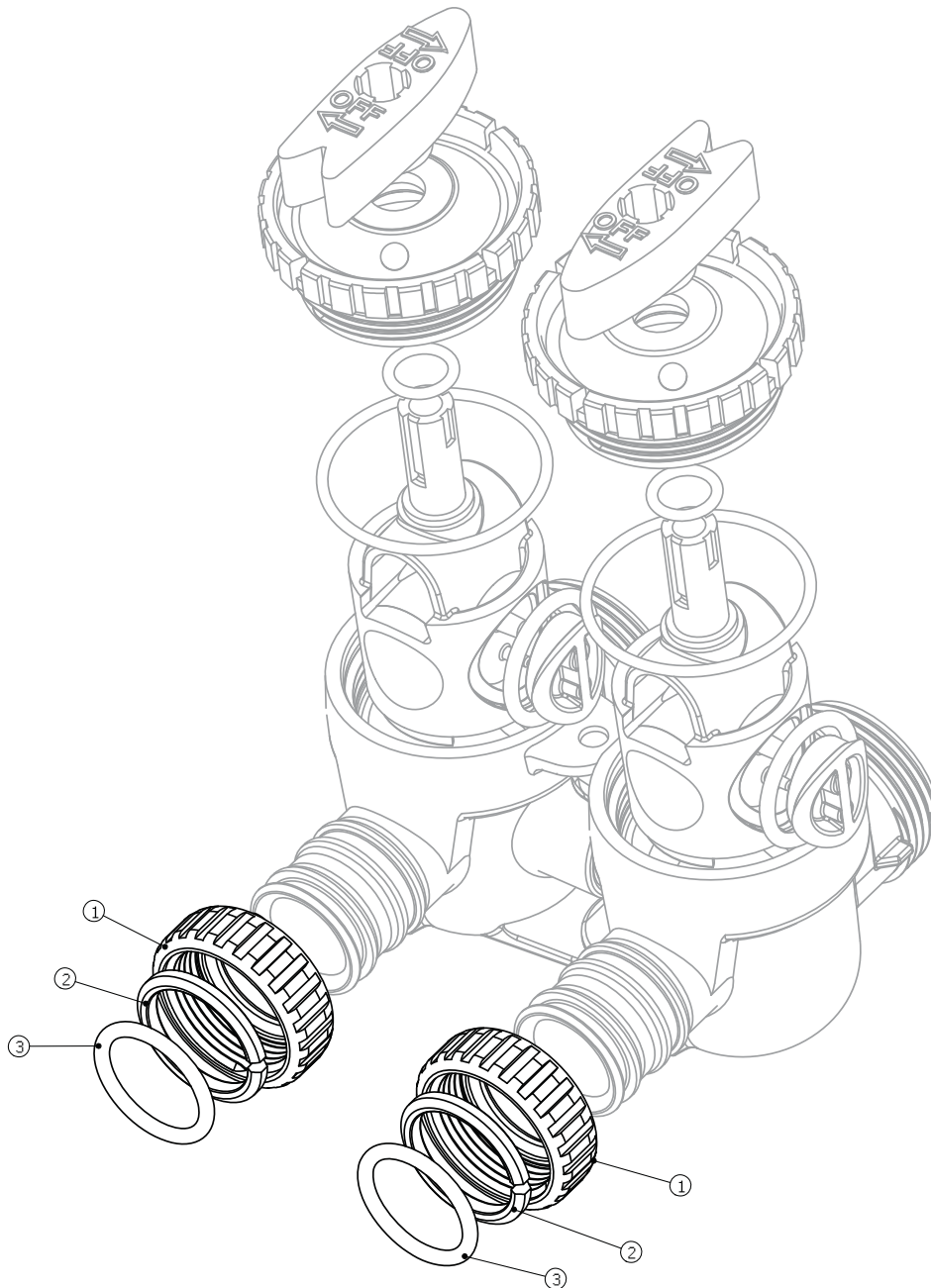

Section 6: INSTALLATION FITTING AND ASSEMBLIES

Quick Connect Assemblies

Part # V3007-02

1" Copper Brass Sweat Adapter

Reference No.	Part No.	Description: 1" Brass Sweat Assembly	Quantity
1	V3151	1" Quick Connect Nut	2
2	V3150	1" Quick Connect Split Ring	2
3	V3105	1" Quick Connect O-Ring 215	2
4	V3188	1" Quick Connect Brass Sweat Assembly	2

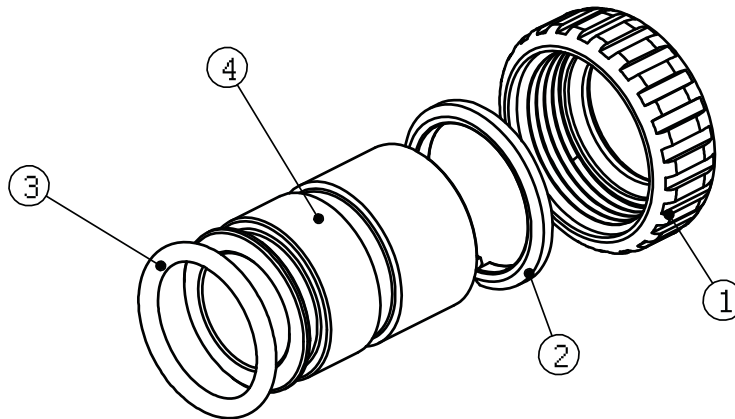

Part # V3007-04

1" Plastic Male NPT Assembly

Reference No.	Part No.	Description	Quantity
1	V3151	1" Quick Connect Nut	2
2	V3150	1" Quick Connect Ring	2
3	V3105	1" Quick Connect O-Ring 215	2
4	V3164	1" NPT Quick Connect Plastic Male Assembly	2

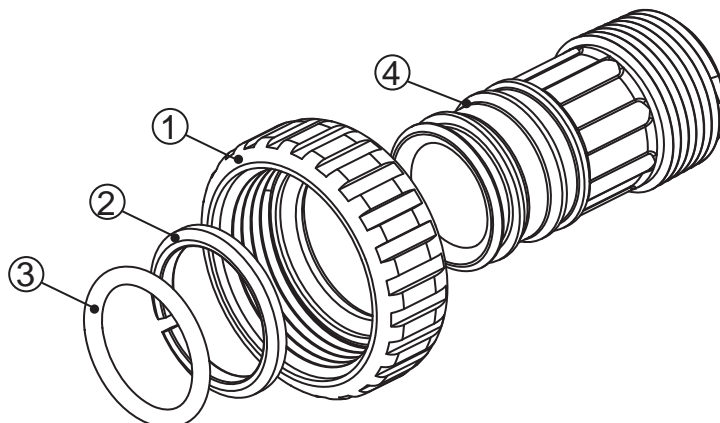

Reference No.	Part No.	Description	Quantity
1	H4615	Elbow Locking Clip	1
2	PKP10T58S-BLK	5/8" Insert Sleeve	1
3	V3192	Quick Connect 3/4" Drain Elbow Nut	1
4	V3158-01	Quick Connect 3/4" Drain Elbow	1
5	V3163	O-ring 019	1
6	V3159-01	Drain Line Flow Control Retainer Assembly	1
7	V3162-042	4.2 gpm Drain Line Flow Control Button	1
7	V3162-053	5.3 gpm Drain Line Flow Control Button	1
7	V3162-075	7.5 gpm Drain Line Flow Control Button	1
7	V-3262-100	10.0 GPM Drain Line Flow Control Button	1

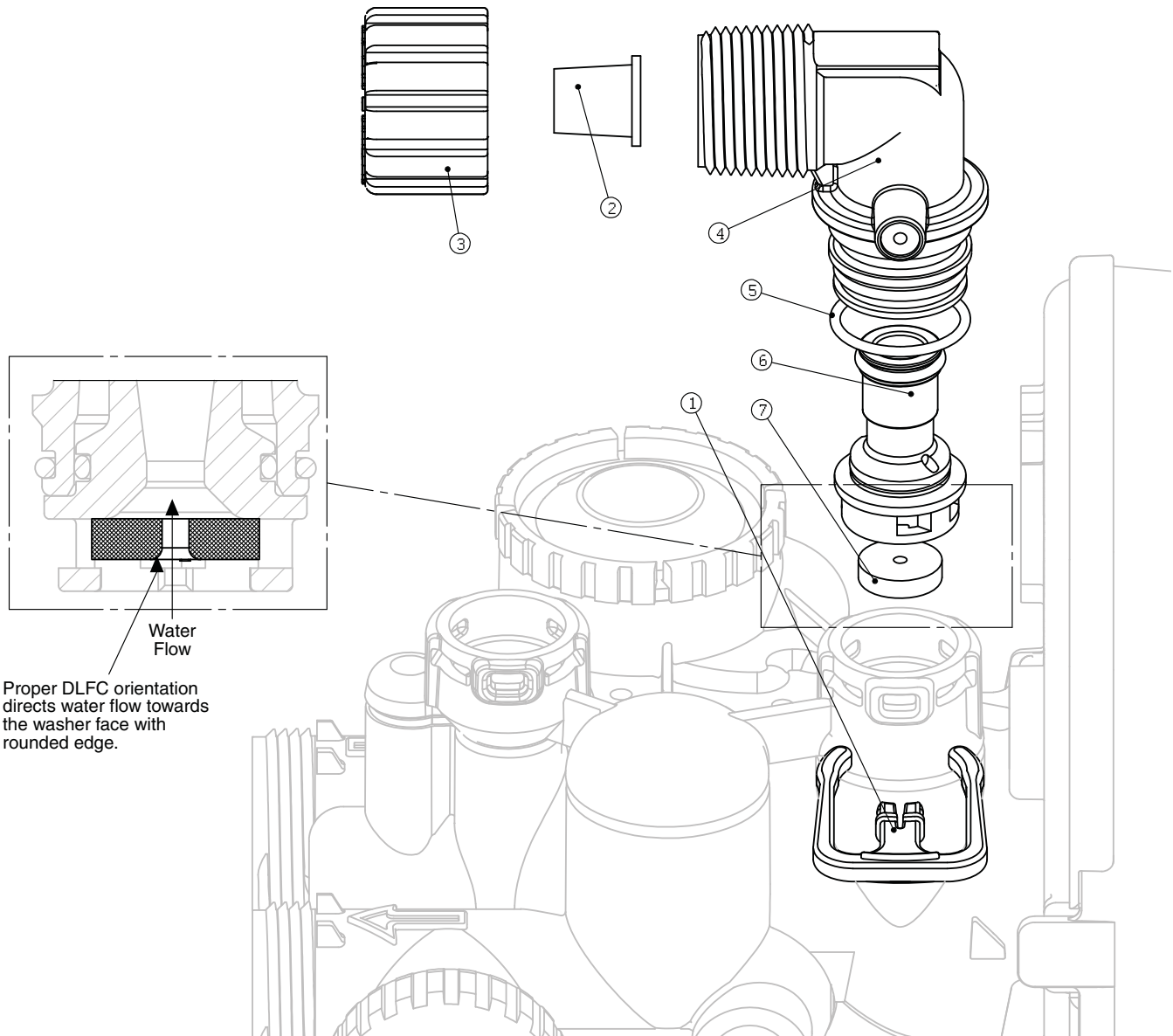

Section 7: MAINTENANCE

Plumbing System Clean-Up

For your new system to operate properly, you may need to clean the entire plumbing system of the precipitated iron that has collected in it or iron “bleed” (staining) will continue to be a problem. The plumbing system includes all water treatment equipment (such as water softeners), water heaters, toilets, and dishwashers. Please refer to the appropriate owner’s manual for instructions.

General Maintenance

Depending on your water quality, it may be necessary to perform maintenance on your filter system in order to ensure continued performance. This is due to low pH, high manganese and/or the sacrificial nature of the filter media. The severity of your pH or the amount of water used will determine how often the filtration system will need to be serviced. pH Plus is a pH boosting material that replenishes the same material that was dissolved into your water to make iron and manganese reduction possible. pH PLUS can be purchased through your Dealer/Installer or our Customer Service Department at 1-800-222-7880.

3M Purification Inc. recommends that you test your treated water pH once a quarter. When iron is the only problem, a water pH needs to be 7.2 higher. When Manganese and Iron are present, the treated water pH needs to 8.2 or higher. The levels can be checked every three (3) months on location with the use of an inexpensive pH test kit that can be purchased locally or from 3M Purification Inc. Our part number for this kit is “17N”. When the pH falls below the recommended level and Iron or Manganese is bleeding through into the finished water, it is time to add the pH Plus component to the filter. The amount of material to add to a filter is as follows.

Standard bed filters

1- 3 ½ pound container of pH Plus for each cubic foot of filter material

Manganese bed filters (Identified by an “M” in the model number, i.e APIF100M)

2- 3 ½ pound containers of pH Plus for each cubic foot of filter material.

Bed Type	Filter Models (Number of Containers to Add)			
Standard Filter Media	APIF100 APIF100DM APIF100J APIF100PT APIF100PTDM (1)	APIF150 APIF150DM APIF150J APIF150PT APIF150PTDM (1 ½)	APIF200 APIF200DM APIF200J APIF200PT APIF200PTDM (2)	APIF300 APIF300J APIF300PT (3)
Manganese Filter Media	APIF100M APIF100MDM APIF100MPT APIF100MPTDM APIF100MJ (1)	APIF150M APIF150MDM APIF150MPT APIF150MPTDM APIF150MJ (1 ½)	APIF200M APIF200MDM APIF200MPT APIF200MPTDM APIF200MJ (2)	APIF300M APIF300MPT APIF300MJ (3)

Step by step procedure to add pH Plus to your iron and manganese reduction system.

- 1) Turn the inlet and outlet knobs of the bypass valve located on the back side of the control valve. See figure 3 in section 3 for proper orientation.
- 2) Manual initiate a backwash cycle to relieve water pressure from the inside of the filter.
- 3) Disconnect the drain line and set aside.
- 4) Remove the control valve from the media tank by rotating the valve head assembly to the left (counter-clockwise).
- 5) Set aside in a secure location for reuse.
- 6) Using the funnel and centering device supplied with the unit originally, install over the distributor tube and inside the opening of the tank to aid in adding the pH Plus material.
- 7) Using a ½ diameter flexible tubing siphon about 12” of water from the tank to allow for adding the pH Plus.
- 8) Pour the recommended amount of pH Plus into the filter media and add water back to filter to expel any air pockets in the tank.
- 9) Reinstall the control valve back on top of tank by attaching the valve head to the media tank by rotating the valve head assembly to the right (clockwise). You may want to apply some silicone lubricant to the O-rings, distributor tube and the inside of the tank opening to facilitate for easier installation. Manually stage control valve to the service position. Refer to Page 3-8, “HOW TO MANUALLY INITIATE IMMEDIATE REGENERATION”.
- 10) Connect both the bypass and the drain line to the control valve and hand tighten only the connection nuts.
- 11) Slowly open the inlet side of the bypass and pressurize the filter, check for leaks, correct if necessary.
- 12) Slowly open the outlet side of the bypass and pressurize the dwelling.
- 13) Manual stage the control to backwash and clean the filter media of any fines that would be present till clear. Allow the control to complete regeneration cycle completely and return to service. Refer to page 3-8, “HOW TO MANUALLY INITIATE IMMEDIATE REGENERATION”.

Section 8: LIMITED WARRANTY

Limited Warranty: 3M Purification Inc. warrants this Product to be free from defects in material and workmanship during normal use for the warranty period set forth below. The warranty period commences from the date of purchase. This warranty does not cover failures resulting from abuse, misuse, alteration or damage not caused by 3M Purification Inc. or failure to follow installation and use instructions. No warranty is given as to the service life of any filter cartridge, membrane, or media as it will vary with local water conditions and water consumption.

3M MAKES NO OTHER WARRANTIES OR CONDITIONS, EXPRESS OR IMPLIED, INCLUDING, BUT NOT LIMITED TO, ANY IMPLIED WARRANTY OR CONDITION OF MERCHANTABILITY OR FITNESS FOR A PARTICULAR PURPOSE OR ANY IMPLIED WARRANTY OR CONDITION ARISING OUT OF A COURSE OF DEALING, CUSTOMER OR USAGE OF TRADE.

If the Product is found defective within the warranty period, your exclusive remedy and 3M Purification Inc.'s sole obligation shall be, at 3M Purification Inc.'s option, to replace or repair the Product or refund the purchase price of the Product. This warranty does not cover labor. The remedy stated in this paragraph is Customer's sole remedy and 3M Purification Inc.'s exclusive obligation.

Warranty Period:

- One (1) year on the entire product unit
- Five (5) years on the media tank only (does not include internal component parts)
- Five (5) years on the control valve
- Five (5) years on salt storage container and components*

Limitation of Liability: 3M Purification Inc. will not be liable for any loss or damage arising from this 3M Purification Inc. product, whether direct, indirect, special, incidental, or consequential, regardless of the legal theory asserted, including warranty, contract, negligence or strict liability. Some states and countries do not allow the exclusion or limitation of incidental or consequential damages, so the above limitation or exclusion may not apply to you.

Warranty Claims:

To obtain warranty service, call 1-800-222-7880 or mail your request to: 3M Purification Inc., 400 Research Parkway, Meriden, CT 06450. Proof of purchase (original sales receipt) must accompany the warranty claim, along with a complete description of the Product, model number and alleged defect. **This warranty gives you specific legal rights, and you may have other rights which may vary from state to state, or country to country.**

* Water Softeners only

NOTES:

NOTES:



3M Purification Inc.

400 Research Parkway
Meriden, CT 06450

1-800-222-7880

www.aquapure.com • www.3mpurification.com

INSTR2188 0313

Aqua-Pure is a trademark of 3M Company used under license.

3M is a trademark of 3M Company.

© 2013 3M Company. All rights reserved.