

910 / 910 ASME (T-M50/T-M50 ASME) On-Demand Water Heater Installation Manual and Owner's Guide



ANSI Z21.10.3
and CSA 4.3



For supplying potable
hot water

ASME model ONLY

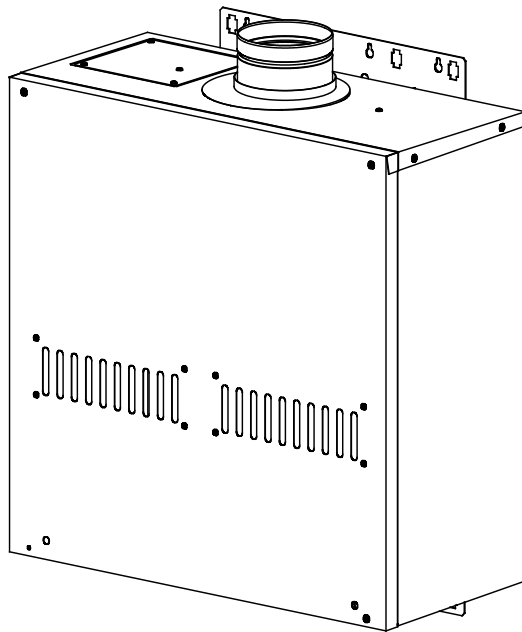

Gas Tankless Water Heater 910 / 910 ASME (T-M50 / T-M50 ASME) Models

*Suitable for potable water heating and space-heating **

**Please refer to local codes for space-heating compliance.*

FEATURING

- ENDLESS HOT WATER
- ON-DEMAND USAGE
- COMPACT, SPACE SAVING
- ENERGY CONSERVATION
- COMPUTERIZED SAFETY
- NO PILOT LIGHT
- EASY-LINK SYSTEM



WARNING

If the information in these instructions is not followed exactly, a fire or explosion may result causing property damage, personal injury or death.

-Do not store or use gasoline or other flammable vapors and liquids in the vicinity of this or any other appliance.

-WHAT TO DO IF YOU SMELL GAS

- Do not try to light any appliance.
- Do not touch any electric switch, do not use any phone in your building.
- Immediately call your gas supplier from a neighbor's phone. Follow the gas supplier's instructions.
- If you cannot reach your gas supplier, call the fire department.

-Installation and service must be performed by a qualified installer, service agency or the gas supplier.

If you have any questions, please call or write to:

500 Tennessee Waltz Parkway
Ashland City, TN 37015
Toll Free: 1-877-737-2840

CONTENTS

SPECIFICATIONS.....	2
INTRODUCTION.....	3
SAFETY GUIDELINES.....	5
INSTALLATION.....	6
General.....	7
Included Accessories.....	7
Warning for Installations.....	8
Outdoor Installation.....	9
Indoor Installation.....	10
Direct Intake Vent System.....	11
Venting Instructions.....	12
Gas Supply / Gas Pipe Sizing.....	16
Water Connections.....	19
Pressure Relief Valve.....	19
Electrical Connections.....	20
Remote Controller Connection.....	21
Pump Control Connections.....	22
Pump Control Mode.....	23
Easy-Link System.....	24
Multi-Unit System.....	27
Initial Operation.....	29
NORMAL OPERATION.....	30
Normal Operation.....	30
Flow.....	32
Freeze Protection System.....	32
Temperature Settings.....	33
Maintenance and Service.....	34
GENERAL TROUBLESHOOTING.....	35
OPERATING SAFETY.....	38
APPLICATIONS.....	40
Re-Circulation.....	40
Dual-Purpose Heating.....	41
ADDITIONAL CLEARANCES.....	42
OPTIONAL ITEMS.....	43
COMPONENTS DIAGRAM.....	44
PARTS LIST.....	48
OUTPUT TEMPERATURE CHART.....	51
LIMITED WARRANTY.....	51

SPECIFICATIONS

Natural Gas Input (Operating Range)		Min: 15,000 Btu/h Max: 380,000 Btu/h	
Propane Input (Operating Range)		Min: 15,000 Btu/h Max: 380,000 Btu/h	
Gas Connection		1" NPT	
Water Connections		1" NPT	
Water Pressure		15 - 150 psi *	
Natural Gas Inlet Pressure		Min. 5.0" WC Max. 10.5" WC	
Propane Inlet Pressure		Min. 8.0" WC Max. 14.0" WC	
Manifold Pressure**		Natural: 2.8" WC Propane: 3.8" WC	
Weight		102 lbs.	
Dimensions		H25.3"×W24.8"×D11.8"	
Ignition		Electric Ignition	
Electric	Supply	120 VAC / 60 Hz	
	Consumption	Operation	178 W (1.48A)
		Standby	16 W (0.13A)
	Freeze-Protection	271 W (2.26A)	

*40 psi or above is recommended for maximum flow.

The Manifold Pressure is the factory setting and generally **should not need adjustment.

NOTE

*All references to the 910 (T-M50) also refer to the 910 ASME (T-M50 ASME) model

*Check the rating plate to ensure this product matches your specifications.

*In accordance with ANSI Z21.10.3, CO emission does not exceed 400 PPM for normal input.

The manufacturer reserves the right to discontinue, or change at any time, specifications or designs without notice and without incurring obligations.

INTRODUCTION

- This manual provides information necessary for the installation, operation, and maintenance of the water heater.
- The model description is listed on the rating plate which is attached to the front cover of the water heater.
- Please read all installation instructions completely before installing this product.
- If you have any problems or questions regarding this equipment, consult with the manufacturer or its local representative.
- This equipment is an on-demand, tankless water heater designed to efficiently supply endless hot water for your needs.
- The water heater has two heat exchangers. The primary and secondary heat exchangers alternate roles, extending the life of the water heater (see p. 4).
- The principle behind the water heater is simple:

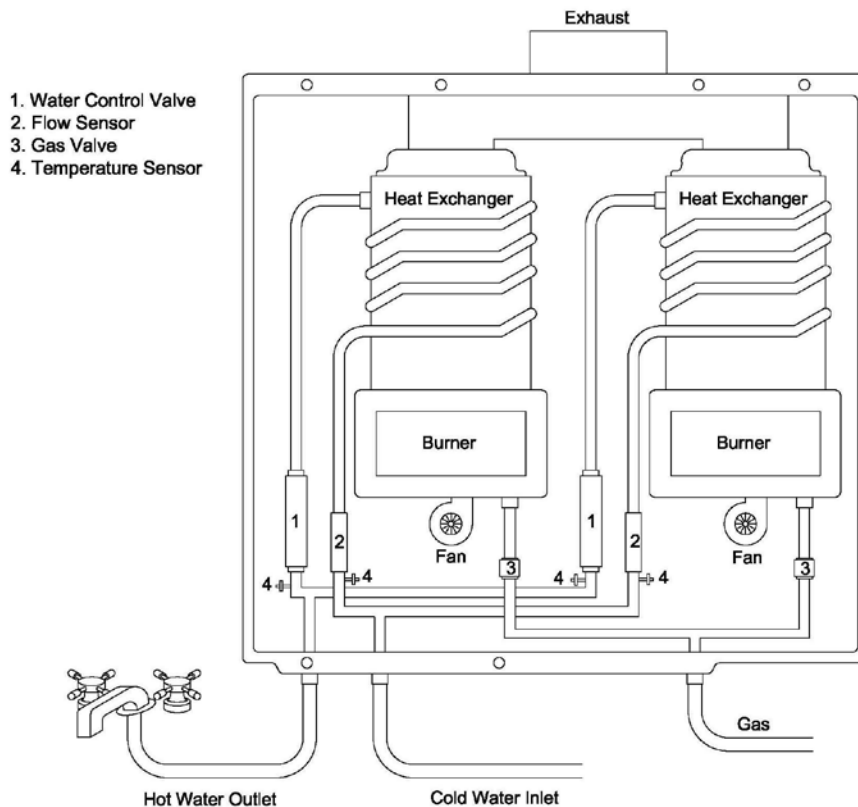

*This diagram illustrates tankless water heater design concepts only and is not accurate to the water heater's physical description.

1. A hot water tap is turned on.
2. Water enters the heater.
3. The water flow sensor detects the water flow.
4. The computer automatically ignites the burner.
5. Water circulates through the heat exchanger and then gets hot.
6. The computer will modulate the gas supply valve and water flow to produce the right amount of hot water at the correct temperature.
7. When the tap is turned off, the unit shuts down.

TWO COMBUSTION SECTIONS WITHIN THE 910 (T-M50)

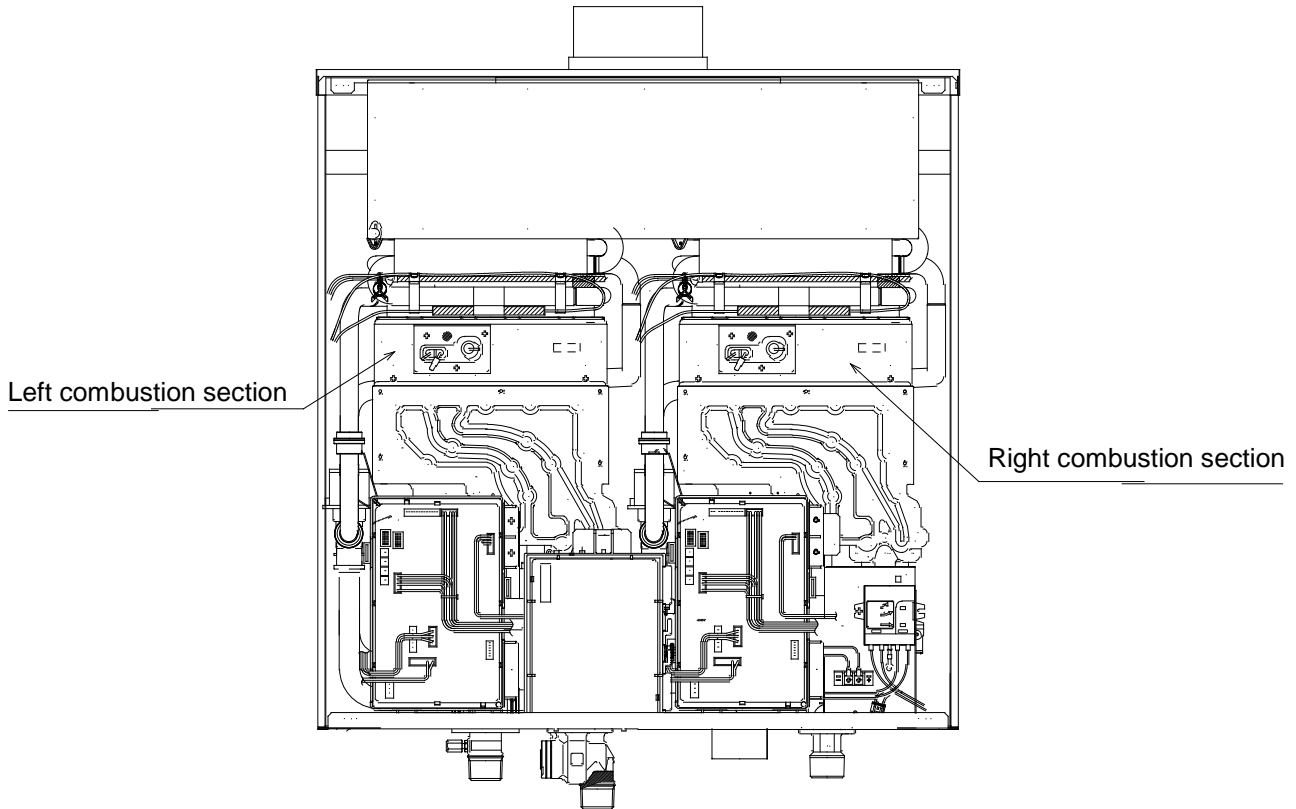

The water heater contains two combustion sections. The section that turns on first is whichever section the water heater decides is the primary section. The moment at which the secondary section fires will depend on the total flow rate and set temperature of the water heater:

Flow rate at which the secondary section fires (GPM)	Set temperature of the 910 (T-M50) (°F)
3.2	100-120
2.9	125,130
2.6	140
2.4	145,150
2.1	155-185

Example: If the set temperature is 120°F:

* The section(s) in operation is indicated by the black square(s).

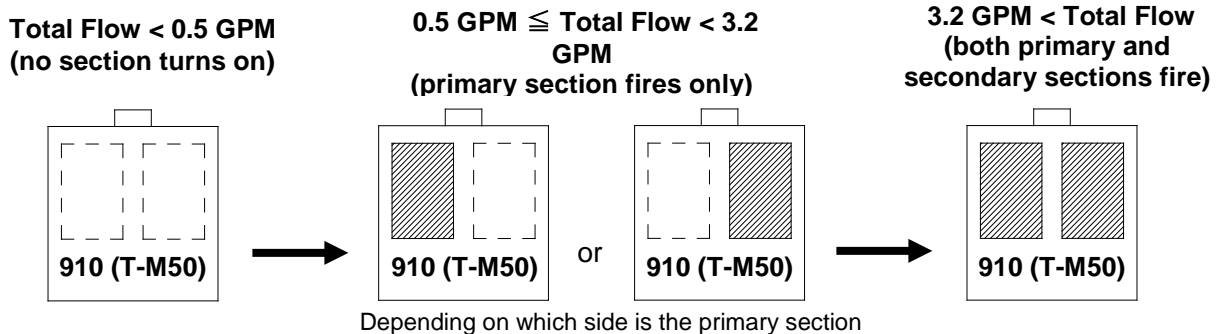

* The primary and secondary section will reverse roles every 100 firing cycles or every 12 hours of unit operation.

SAFETY GUIDELINES



WARNING

- Installation and service must be performed by a qualified installer (for example, a licensed plumber or gas fitter), otherwise the warranty by the manufacturer will be void.
- The installer (licensed professional) is responsible for the correct installation of the water heater and for compliance with all national, state/provincial, and local codes.

PLEASE READ THIS MANUAL CAREFULLY AND FOLLOW ALL DIRECTIONS.

GENERAL

1. Follow all local codes, or in the absence of local codes, follow the most recent edition of the National Fuel Gas Code: ANSI Z223.1/NFPA 54 in the USA or CAN/CSA B149.1 Natural Gas, Propane Installation Code in Canada.
2. Properly ground the unit in accordance with all local codes or in the absence of local codes, with the National Electrical Codes: ANSI/NFPA 70 in the USA or CSA standard C22.1 Canada Electrical Code Part 1 in Canada.
3. Carefully plan where you intend to install the water heater. Please ensure:
 - Your water heater will have enough combustible air and proper ventilation.
 - Locate your heater where water leakage will not damage surrounding areas (please refer to p. 6).
4. Check the rating plate for the correct **GAS TYPE, GAS PRESSURE, WATER PRESSURE and ELECTRIC RATING.**
*If this unit does not match your requirements, **do not install and consult with the manufacturer.**
5. If any problem should occur, turn off all hot water taps and turn off the gas. Then call a trained technician or the Gas Company or the manufacturer.

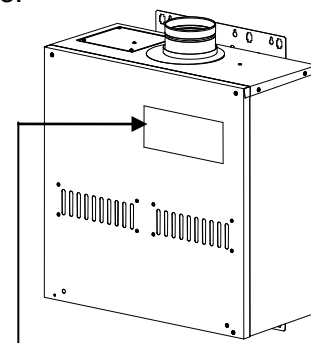

Rating plate

WARNING

- Water temperatures over 125 °F (52 °C) can cause severe burns instantly or death from scalding. The water temperature is set at 120 °F (50 °C) from the factory to minimize any scalding risk. Before bathing or showering always check the water temperature.



Prohibited

- Do not store or use gasoline or other flammables, vapors, or liquids in the vicinity of this appliance.
- Do not reverse the water and/or gas connections as this will damage the gas valves and can cause severe injury or death. Follow the diagram on p. 19 when installing your water heater:
- Do not use this appliance if any part has been in contact with or been immersed in water. Immediately call a licensed plumber, a licensed gas fitter, or a professional service technician to inspect and/or service the unit if necessary.
- Do not disconnect the electrical supply if the ambient temperature will drop below freezing. The Freeze Prevention System only works if the unit has electrical power. The warranty will not be covered if the heat exchanger is damaged due to freezing. Refer to the section on the Freeze Prevention System on p. 32 for more information.



INSTALLATION

All gas water heaters require careful and correct installation to ensure safe and efficient operation. This manual must be followed exactly. Read the "Safety Guidelines" section at the beginning of this manual.



CAUTION

- **The warranty will not cover damage caused by water quality.** Water hardness that leads to scale formation and/or corrosion may affect/damage the water heater. Hard water scaling and/or corrosion must be avoided or controlled by proper water treatment.
- **The manufacturer recommends using the direct-vent kit, when the water heater is installed in a beauty salon.** Some chemicals used in a beauty salon may affect the flame sensor. Water heater may not work properly.
- Although this water heater is designed to operate with minimal sound, **the manufacturer does not recommend installing the unit on a wall adjacent to a bedroom, or a room that is intended for quiet study or meditation, etc.**
- Locate your heater close to a drain where water leakage will not do damage to surrounding areas. As with any water heating appliance, the potential for leakage at some time in the life of the product does exist. The manufacturer will not be responsible for any water damage that may occur. If you install a drain pan under the unit, ensure that it will not restrict the combustion air flow.



WARNING



- The water heater weighs 102 lbs. **Ensure that any and all support structures (whether it is installed on a wall, on a support stand, etc.) have enough strength to support and hold the water heater.**
- **When handling the water heater, do not place your hands inside the flue collar. Injury may result.**
- **The manufacturer does not recommend installing unit in an attic due to safety issues.** If you install your water heater in an attic:
 - Make sure your unit will have enough combustion air and proper ventilation.
 - Keep the area around your water heater clean. When dust collects on the flame sensor, the water heater will shut down on errors.
 - If the above conditions cannot be met, use the direct-vent conversion kit 9007669005 (TM-DV50).
 - Locate unit for easy access for service and maintenance.
 - A drain pan is required to be installed under the water heater in case of leaks.

GENERAL

1. The manifold gas pressure is preset at the factory. It is computer controlled and should not need adjustment.
2. Maintain proper space for servicing. Install the unit so that it can be connected or removed easily. Refer to p. 9 and p. 10 for proper clearances.
3. The electrical connection requires a means of disconnection, to terminate power to the water heater for servicing and safety purposes.
4. If you will be installing the unit in a contaminated area with a high level of dust, sand, flour, aerosols or other contaminants/chemicals, they can become airborne and enter and build up within the fan and burner causing damage to the unit. In those environments (e.g. residential or commercial laundry facilities, hair salons, pet salons, chemical plants etc.), please purchase the optional direct-vent conversion kit and convert the water heater to a sealed combustion unit. Direct venting allows the water heater to draw fresh intake air from the outside. The warranty will not cover damage caused to the unit due to installation in a contaminated environment that has not been converted using the direct-vent conversion kit.
5. Particles from flour, aerosols, and other contaminants may clog the air vent or reduce the functions of the rotating fan and cause improper burning of the gas. Regularly ensure that the area around the unit is dust- or debris-free; regular maintenance is recommended for these types of environment.
6. Do not install the unit where the exhaust vent is pointing into any opening in a building or where the noise may disturb your neighbors. Make sure the vent termination meets the required distance by local code from any doorway or opening to prevent exhaust from entering a building (refer to p. 15).

INCLUDED ACCESSORIES

Check that these items below are included with the water heater.

Items	
Manual	 Qty: 1
Communication Cable	 Gray Qty: 1

WARNING FOR INSTALLATIONS

FOR YOUR SAFETY, READ BEFORE INSTALLATION:

Do not install the heater where water, debris or flammable vapors may get into the flue terminal. This may cause damage to the heater and void the warranty.



Prohibited



Do not have the vent terminal pointing toward any opening into a building. Do not locate your heater in a pit or location where gas and water can accumulate.



Prohibited



Do not install this water heater under an overhang less than 3 feet from its top or eaves. The area under an overhang must be open to three sides.

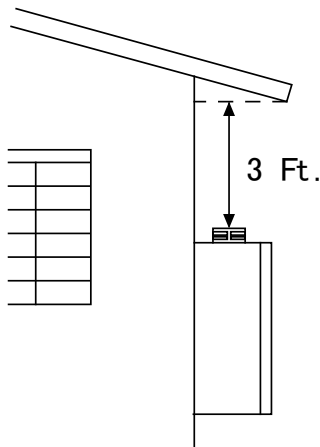

Do not install the water heater vent terminator within 1 ft. in the USA of any air intake or building opening, and within 3 ft. in Canada of any air intake or building opening. (Refer to p.15)

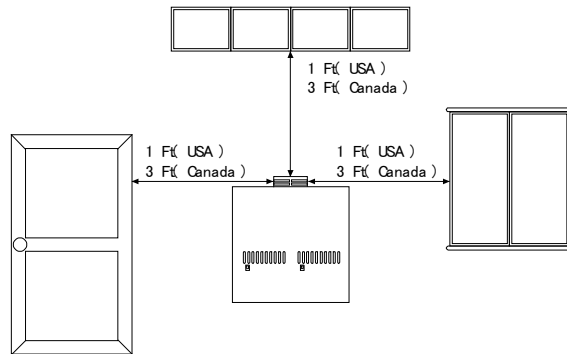

Do not install next to a dryer or any source of airborne debris that can be trapped inside the combustion chamber, unless the system is direct vented.

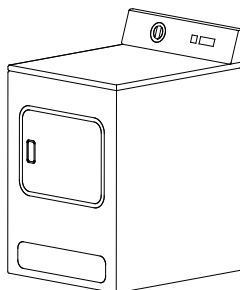

OUTDOOR INSTALLATION

1. Follow all local codes, or in the absence of local codes, follow the most recent edition of the National Fuel Gas Code: ANSI Z223.1/NFPA 54 in the USA or CAN/CSA B149.1 Natural Gas, Propane Installation Code in Canada.
2. **Install outdoors only in areas with mild, temperate climates.**
3. Ensure that the unit is set for outdoor installation. Locate the **central computer board**. On the central computer board, locate the lower bank of dipswitches **to the right** of the 7-Seg. LED on the computer board. The 'OUT' dipswitch on that bank should be switched to its 'ON' (up) position (Do not adjust the upper bank of dipswitches).



Make sure power to the unit is turned OFF before changing the dipswitch settings.

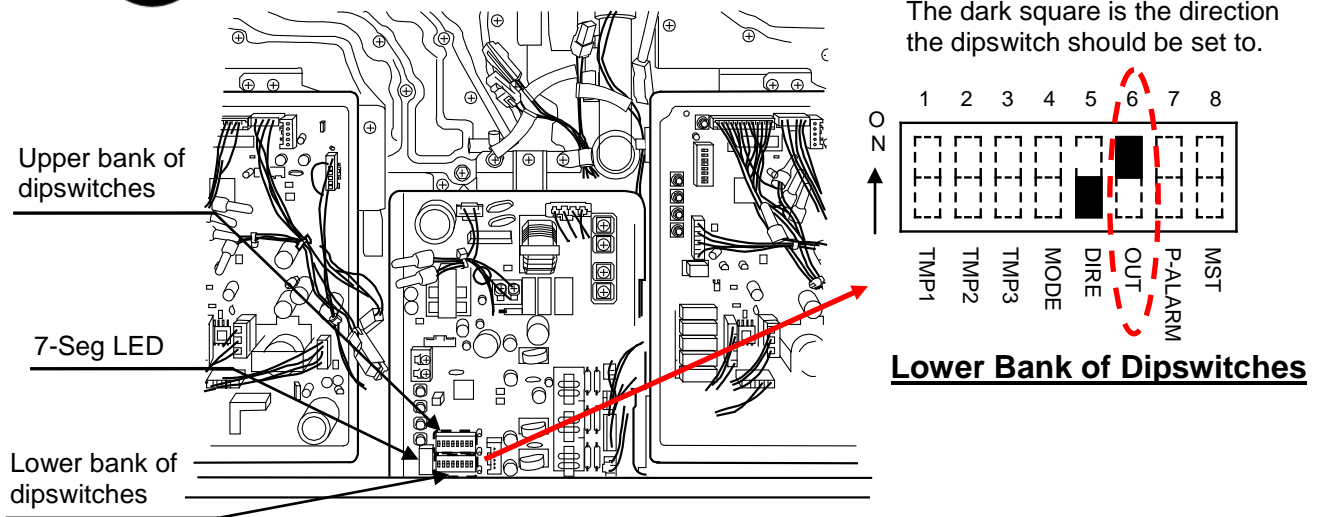

4. The outdoor vent cap must be used when unit is installed outdoor. The manufacturer requires the use of its part No. 9007677005 (TM-VC50).
5. When installed outdoors, the water heater shall be wall-mounted or mounted on a stand. Locate the water heater in an open, unroofed area and maintain the following minimum clearances:



There is a 2" clearance from the left and right sides of the unit to combustible and non-combustible surfaces. However, if any portion or area of the surface is exposed to the exhaust fumes (i.e. directly to the sides of the vent cap), that surface must be at least 24" away.



Keep the clearances.

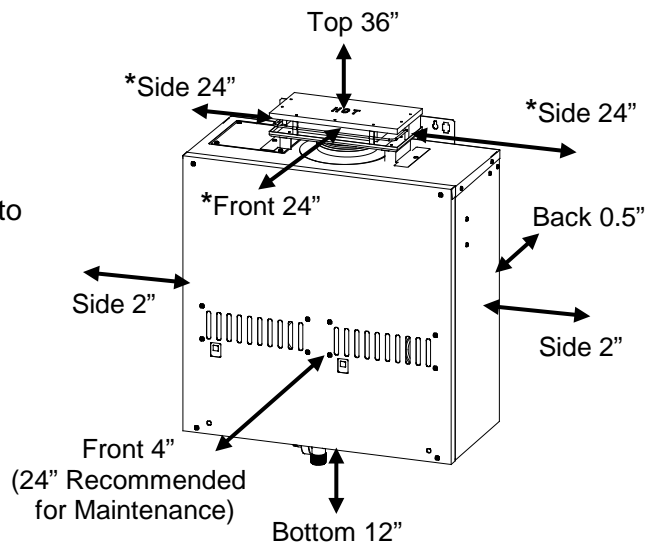

INDOOR INSTALLATION

1. Follow all local codes, or in the absence of local codes, follow the most recent edition of the National Fuel Gas Code: ANSI Z223.1/NFPA 54 in the USA or CAN/CSA B149.1 Natural Gas, Propane Installation Code in Canada.
2. When installed indoors, the water heater shall be located in an area to maintain the following minimum clearances around the unit:



Keep the clearances.

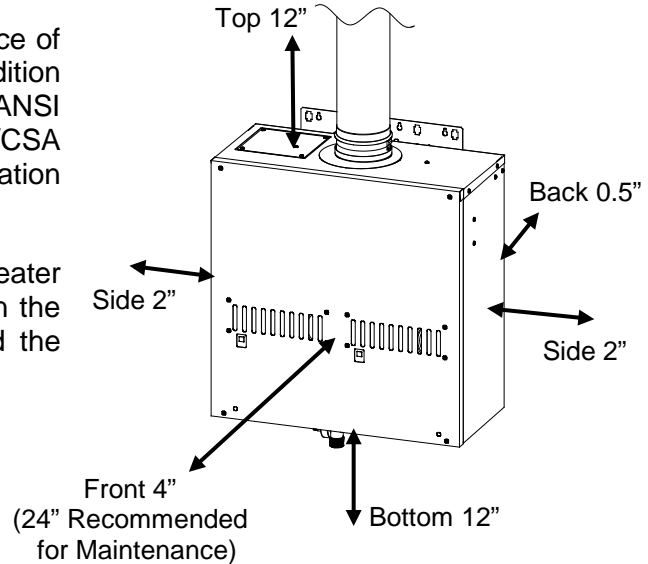

Combustion Air Supply

The water heater location must provide enough air for proper combustion and ventilation of the surrounding area. See the latest edition of ANSI Standard Z223.1 or any applicable local codes. In general, these requirements specify that if the unit is installed in a confined space, there must be a permanent air supply opening.

Minimum recommended air supply opening size for water heater:

Water heater size	When drawing make-up air from outside the building	When drawing make-up air from inside the building (from other rooms within)
MAX 380,000 BTU/h	25.3 Sq. IN	380 Sq. IN
	When combustion air is supplied from outside the building, an opening communicating directly with the outside should have a minimum free area of one square inch per 15,000 BTUH input of the total input rating of water heater in the enclosed area.	When combustion air is supplied from inside the building, an opening communicating with the rest of the dwelling should have a minimum free area of one square inch per 1,000 BTUH input of the total input rating of water heater in the enclosed area. This opening should never be less than 199 sq. in.

Combustible Air Supplied by Mechanical fan or Make up air device

The water heater is equipped with a combustible air sensor that will shut off the unit when inadequate combustible air supply to unit is detected.

- If a mechanical fan or make up air device is used to supply air to the water heater or utility room, the installer should make sure it does not create drafts which could cause nuisance shutdowns.
- If a blower is necessary to provide adequate combustion air to the water heater, the blower and water heater must be set up so that the water heater cannot fire unless the blower is operating. Possible methods include the use of the water heater internal fan control port or the use of external flow sensors/transmitters and relays.

DIRECT INTAKE VENT SYSTEM

This water heater may be converted to a direct-vent (sealed combustion) appliance by installing an adapter (Part No. 9007669005 (TM-DV50)) which will bring all required combustible air from outside the building. When installing the direct-vent conversion kit, please follow all instructions included with the kit.

- The water heater must be installed in a location where the proper amount of combustible air will be available to it at all times without obstructions.
- If used as a direct-vent appliance, the water heater requires a 5" combustible air supply pipe. The intake pipe must be sealed airtight.
- Air supply pipe can be made of ABS, PVC, galvanized steel, corrugated aluminum, corrugated stainless steel or Category III stainless steel.
- Change the dipswitch settings to the direct-vent system. (See diagram below)
- Sidewall venting is recommended for the direct-vent system.
- The manufacturer recommends running the exhaust vent and the intake pipe parallel.



Make sure power to the unit is turned OFF before changing the dipswitch settings.

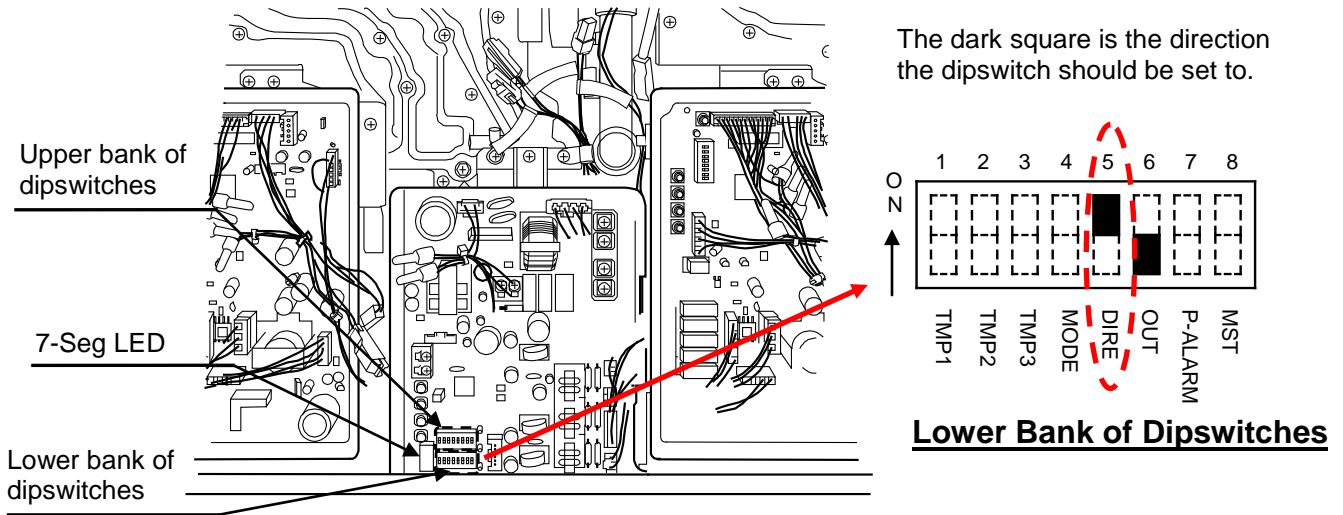

Direct-Vent Conversion Kit

DIRECT-VENT CONVERSION KIT

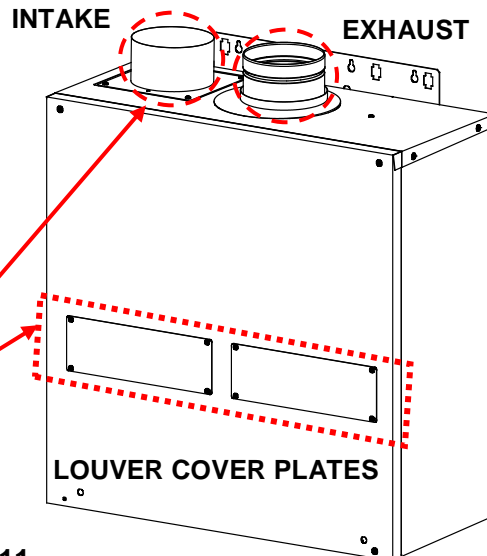

VENTING INSTRUCTIONS



WARNING: Improper venting of this appliance can result in excessive levels of carbon monoxide which can result in severe personal injury or death.

This water heater must be vented in accordance with the section "Venting of Equipment" of the latest edition of the Natural Fuel Gas Code: ANSI Z223.1, all applicable local building codes, and Section 7 of CAN/CSA B149.1 Natural Gas in Canada, Propane Installation Code in Canada.

EXHAUST VENT

This is a Category III appliance and must be vented accordingly. The vent system must be sealed airtight. All seams and joints **without gaskets** must be sealed with high heat resistant silicone sealant or UL listed aluminum adhesive tape having a minimum temperature rating of 350 °F. For best results, a vent system should be as short and straight as possible.

1. This water heater is a Category III appliance and must be vented accordingly with any 5" vent approved for use with Category III or Special BH type gas vent.
2. **The manufacturer recommends the NovaVent line.** However, the following are also UL listed manufacturers: ProTech Systems Inc. (FasNSeal), Metal-Fab Inc., and Heat-Fab Inc. (Saf-T Vent).
3. **Follow the vent pipe manufacturer's instructions when installing the vent pipe.**
4. **Do not common vent this appliance with any other vented appliance.** (Do not terminate vent into a chimney. If the vent must go through the chimney, the vent must run all the way through the chimney with Category III approved or Special BH vent pipe.)
5. The maximum length of exhaust vent piping must not exceed 50 ft. deducting 5 ft. for each elbow used in the venting system. Do not use more than 5 elbows.

Diameter	Max. No. of Elbows	Max. Vertical or Horizontal Length
5"	5 Ea.	50 ft

***For each elbow added, deduct 5 ft. from max. vent length.**

No. of Elbows	Max. Vertical or Horizontal Length
0	50 ft.
1	45 ft.
2	40 ft.
5	25 ft.

6. When the horizontal vent run exceeds 5 ft., support the vent run at 3 ft. intervals with overhead hangers.
7. The manufacturer will not be responsible for any damage to the water heater caused by condensation from the vent. For horizontal runs, slope the vent run downwards toward the vent terminal at a rate of ¼" per foot. For horizontal runs that do not slope downward and for vertical runs, installing a condensate drain is recommended. Please refer to p. 14 for the diagrams.



When installing the vent system, all applicable national and local codes must be followed. If you install thimbles, fire stops or other protective devices and they penetrate any combustible or noncombustible construction, be sure to follow all applicable national and local codes.

VENT TERMINATION



WARNING: Improper installation can cause nausea or asphyxiation, severe injury or death from carbon monoxide and flue gases poisoning. Improper installation will void product warranty.

- The vent termination provides a means of installing vent pipe through the building wall and must be located in accordance with ANSI Z223.1/NFPA 54, or in Canada with CAN/CSA-B149.1 and local applicable codes.
- A proper sidewall vent termination is recommended when the water heater is vented through a sidewall. If the water heater is converted to a direct-vent unit, a proper sidewall direct-vent termination is to be used.

General rules for venting the water heater are:

1. Place the water heater as close as possible to the vent termination.
2. The vent collar of the water heater must be fastened directly to an unobstructed vent pipe.
3. Do not weld the vent pipe to the water heater collar.
4. Do not cut the vent collar of the unit.
5. The weight of the vent stack must not rest on the water heater.
6. The vent must be easily removable from the top of the water heater for normal service and inspection of the unit.
7. The water heater vent must not be connected to any other gas appliance or vent stack.
8. Avoid locating the water heater vent termination near **any air intake devices**. These fans can pick up the exhaust flue products from the water heater and return them to the building. This can create a health hazard.
9. Avoid using an oversized vent pipe or using extremely long runs of the pipe.
10. Locate the vent termination so that it cannot be blocked by any debris, at any time. Most codes require that the termination be at least 12 inches above grade, but the installer may determine if it should be higher depending on the job site condition and applicable codes.
11. For rooftop venting, a rain cap must be installed.

Horizontal Installation Diagram

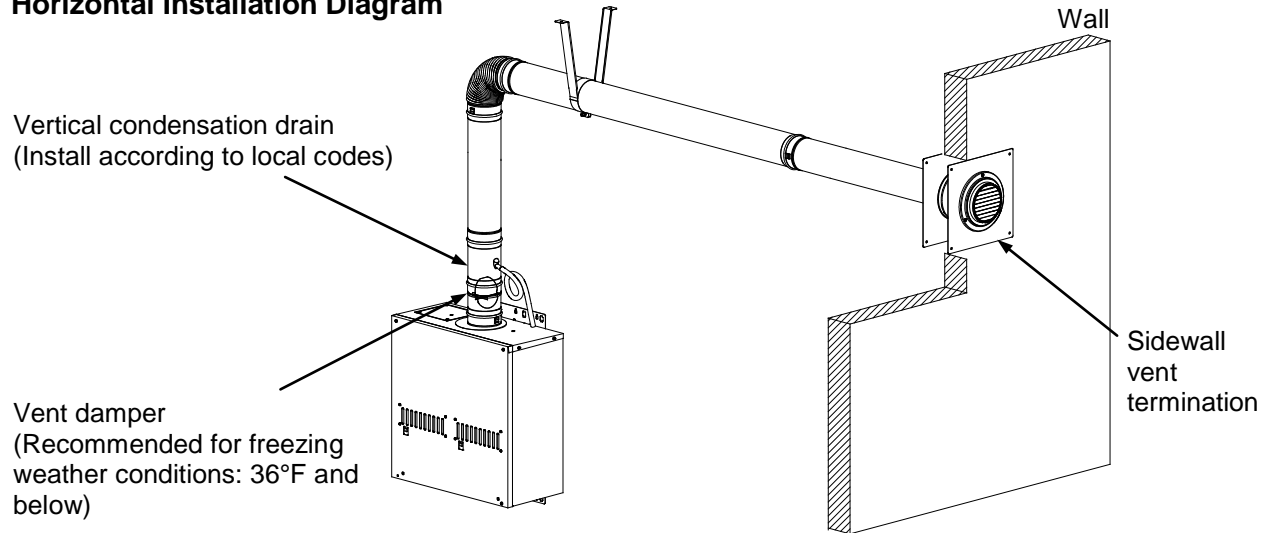

Vertical Installation Diagram

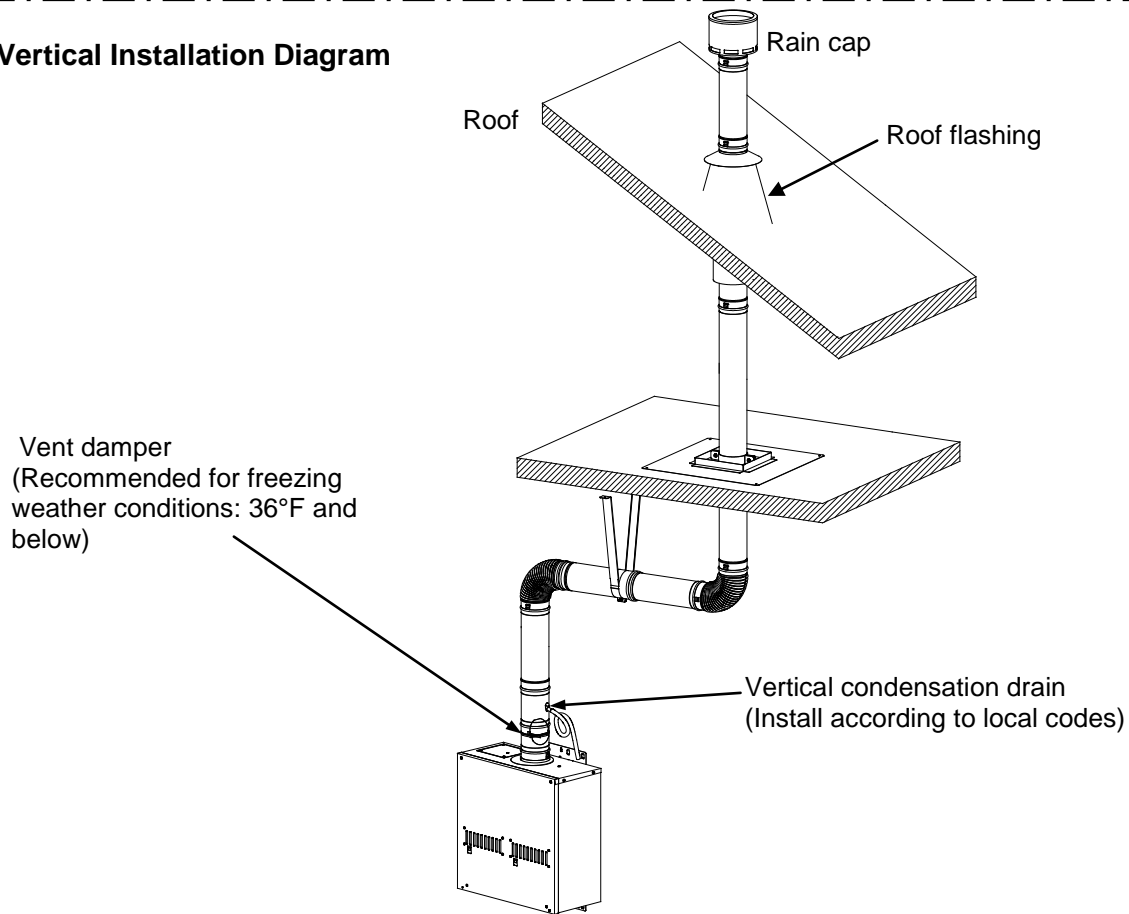

- Regarding the clearance from the terminal to the air inlet or opening, refer to the next page.
- Install a condensation drain in the venting.
- Follow the vent manufacturer's instructions and local codes.
- Do not common vent or connect any vent from other appliances to the water heater vent.
- Use 5" category III approved or Special BH, single or double wall stainless steel vent pipe.

VENT CLEARANCES

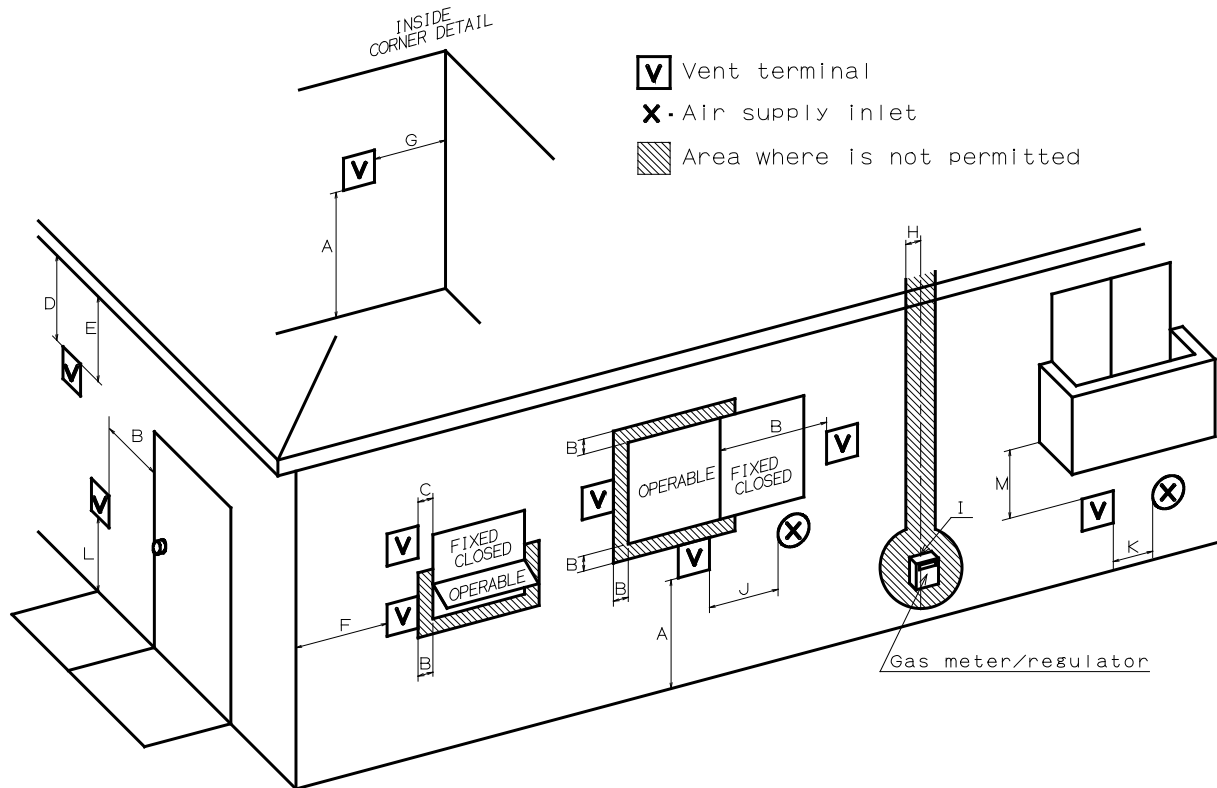

		Canada	U.S.A	
		Direct vent and other than Direct Vent	Direct vent	Other than Direct Vent
A	Clearance above grade, veranda, porch, deck, or balcony.	1 foot	1 foot	1 foot
B	Clearance to window or door that may be opened.	3 feet	1 foot	4 feet from below or side opening. 1 foot from above opening.
C	Clearance to permanently closed window	*	*	*
D	Vertical clearance to ventilated soffit located above the vent terminator within a horizontal distance of 2 feet (61cm) from the center line of the terminator.	*	*	*
E	Clearance to unventilated soffit	*	*	*
F	Clearance to outside corner	*	*	*
G	Clearance to inside corner	*	*	*
H	Clearance to each side of center line extended above meter/regulator assembly	3 feet	*	*
I	Clearance to service regulator vent outlet.	3 feet	*	*
J	Clearance to non-mechanical air supply inlet to building or the combustion air inlet to any other application.	3 feet	1 foot	4 feet from below or side opening. 1 foot from above opening.
K	Clearance to mechanical air supply inlet.	6 feet	3 feet	3 feet
L	Clearance above paved sidewalk or paved driveway located on public property.	7 feet	*	7 feet
M	Clearance under veranda, porch deck, or balcony.	1 foot	*	*

*For clearances not specified in ANSI Z223.1 / NFPA 54 or CAN/CSA-B149.1, please use clearances in accordance with local installation codes and the requirement of the gas supplier.

GAS SUPPLY AND GAS PIPE SIZING

TO TURN OFF GAS TO APPLIANCE

1. Turn off all electric power to the water heater if service is to be performed.
2. Turn the manual gas valve located on the outside of the unit clockwise \curvearrowright to the off position.



WARNING: Conversion of this unit from natural gas to propane or vice versa will void all warranty. Contact your local distributor to get the correct unit for your gas type. **The manufacturer is not liable for any property and/or personal damage resulting from gas conversions.**

***Check that the type of gas matches the rating plate first.**

- The minimum and maximum inlet gas pressures are:

Gas type	Inlet gas pressure
Natural Gas	Min. 5.0" WC – Max. 10.5" WC
Propane	Min. 8.0" WC – Max. 14.0" WC

- Inlet gas pressures that fall outside the range of values listed above may adversely affect the performance of the water heater. These pressures are measured when the water heater is in full operation.
- Inlet gas pressure must not exceed the above maximum values; gas pressure above the specified range will cause dangerous operating conditions and damage to the unit. Ensure that any and all gas regulators used are operating properly and are providing gas pressures within the specified range shown above.
- Until testing of the main gas line supply pressure is completed, ensure the gas line to the water heater is disconnected to avoid any damage to the water heater.

-Gas connections-

1. Install a manual gas shutoff valve between the water heater and the gas supply line.
2. When the gas connections are completed, it is necessary to perform a gas leak test either by applying soapy water to all gas fittings and observing for bubbles or by using a gas leak detection device.
 - The water heater and its individual shutoff valve must be disconnected from the gas supply piping system during any pressure testing of that system at test pressures in excess of 1/2 psi (3.5 kPa).
 - The water heater must be isolated from the gas supply piping system by closing its individual manual shutoff valve during any pressure testing of the gas supply piping system at test pressures equal to or less than 1/2 psi (3.5kPa).
3. Always purge the gas line of any debris and/or water before connecting to the gas inlet.

NOTICE

Size the gas pipe appropriately to supply the necessary volume of gas required for the water heater using ANSI Z223.1/NFPA 54 in the USA or CAN/CSA B149.1 in Canada or local codes. Otherwise, flow capabilities and output temperatures will be limited.

Natural Gas Supply Piping

Maximum Delivery Capacity of Cubic Feet of Gas per Hour of IPS Pipe Carrying Natural Gas of 0.60 Specific Gravity Based on Pressure Drop of 0.5" WC

Based on Energy Content of 1,000 BTU/Cubic Ft.: 910 (T-M50) requires 380 Cubic Ft./hr. Unit: Cubic Feet per Hour

Pipe Size Diameter	Length												
	10'	20'	30'	40'	50'	60'	70'	80'	90'	100'	125'	150'	200'
3/4"	363	249	200	171	152	138	127	118	111	104	93	84	72
1"	684	470	377	323	286	259	239	222	208	197	174	158	135
1 1/4"	1,404	965	775	663	588	532	490	456	428	404	358	324	278
1 1/2"	2,103	1,445	1,161	993	880	798	734	683	641	605	536	486	416
2"	4,050	2,784	2,235	1,913	1,696	1,536	1,413	1,315	1,234	1,165	1,033	936	801
2 1/2"	6,455	4,437	3,563	3,049	2,703	2,449	2,253	2,096	1,966	1,857	1,646	1,492	1,277
3"	11,412	7,843	6,299	5,391	4,778	4,329	3,983	3,705	3,476	3,284	2,910	2,637	2,257

Propane (LP) Gas Supply Piping

Maximum Capacity of Propane (LP) Gas Based on 11" WC supply pressure at a 1.0" WC pressure drop

Unit: kBtu per Hour

Pipe Size Diameter	Length												
	10'	20'	30'	40'	50'	60'	70'	80'	90'	100'	125'	150'	200'
3/4"	567	393	315	267	237	217	196	185	173	162	146	132	112
1"	1,071	732	590	504	448	409	378	346	322	307	275	252	213
1 1/4"	2,205	1,496	1,212	1,039	913	834	771	724	677	630	567	511	440
1 1/2"	3,307	2,299	1,858	1,559	1,417	1,275	1,181	1,086	1,023	976	866	787	675
2"	6,221	4,331	3,465	2,992	2,646	2,394	2,205	2,047	1,921	1,811	1,606	1,496	1,260

Gas Sizing Example (Natural Gas)

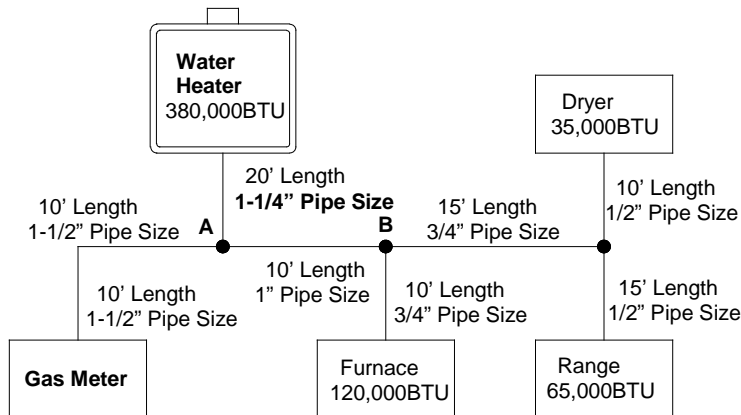

Based on Energy Content of 1,000BTU/Cubic Ft.

Divide each appliance's BTU requirement by 1,000BTU to get the appliances Cubic Ft. requirement.

Take into account the distance the appliance is from the gas meter, look in the above gas chart to properly size the line.

For sections of the gas line supplying gas to more than one appliance (Ex: Point A to Point B), add up the cubic ft. requirements of the appliances that are being supplied by that section, and size to the farthest appliance.

For Example: The section from A to B supplies gas to the furnace, range, and dryer. Adding up the BTU requirements and dividing by 1,000 yields a cubic ft. requirement of 220 cubic ft. of gas. The farthest appliance is the range, which is 60 ft. away from the meter. Looking at the above chart, and under the column of 60ft., Section A to B needs to be 1" in order to supply 220 cubic ft.

-Measuring inlet gas pressure-



1. Turn off all electric power to the water heater if service is to be performed.
2. Turn the manual gas valve located on the outside of the unit clockwise \cup to the off position.

The water heater cannot perform properly without sufficient inlet gas pressure. Below are instructions on how to check the inlet gas pressure. **THIS IS ONLY TO BE DONE BY A LICENSED PROFESSIONAL.**

1. Shut off the manual gas valve on the supply gas line.
2. Remove the screw for the pressure port located on the gas inlet of the water heater shown in the diagram to the right.
3. Connect the manometer to the pressure port.
4. Re-open the manual gas valve. Check to see that there are no gas leaks. Open some of the fixtures that use the highest flow rate to turn on the water heater.
5. Check the inlet gas pressure. When the water heater is on maximum burn, the manometer should read from 5.0" to 10.5" WC for Natural gas, from 8.0" to 14.0" WC for Propane.

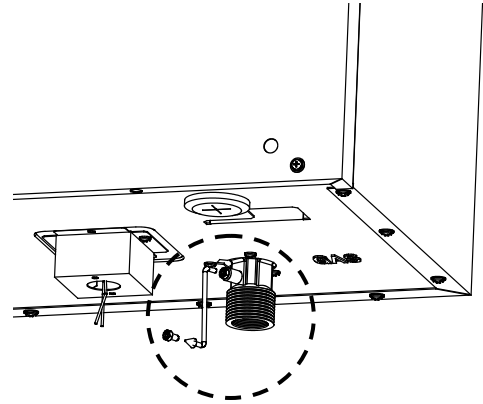

WATER CONNECTIONS

FOR YOUR SAFETY, READ BEFORE OPERATING:

- Do not use this water heater if any part has been submersed under water. Immediately call a licensed professional to inspect the water heater and to replace any damaged parts.
- Do not reverse the hot outlet and cold inlet connections to the water heater. This will not activate the water heater.

1. All pipes, pipe fittings, valves and other components, including soldering materials, must be suitable for potable water systems.
2. A manual shut off valve must be installed on the cold water inlet to the water heater between the main water supply line and the water heater.
3. In addition, a manual shut off valve is also recommended on the hot water outlet of the unit. If the water heater is installed within, or subjected to, a closed loop water system, a thermal expansion tank must be installed.
4. **Before installing the water heater, flush the water line to remove all debris, and after installation is complete, purge the air from the line. Failure to do so may cause damage to the heater.**
5. There is a wire mesh filter within the cold inlet to trap debris from entering your heater. This will need to be cleaned periodically to maintain optimum flow.

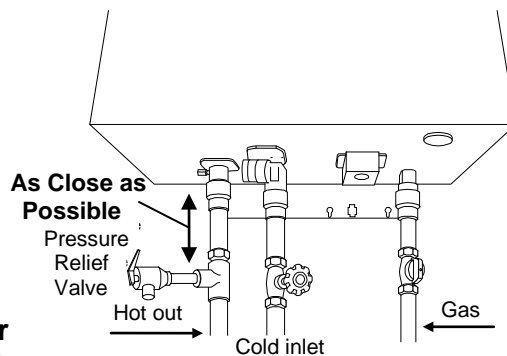

PRESSURE RELIEF VALVE

The water heater has a high-temperature shut off switch built in as a standard safety feature (called a Hi-Limit switch) therefore a “**pressure only**” relief valve is required.

- This unit does not come with an approved pressure relief valve.
- An approved pressure relief valve must be installed on the hot water outlet.
- The pressure relief valve must conform to ANSI Z21.22 or CAN 1-4.4 and installation must follow local code.
- The discharge capacity must be at least 380,000 BTU/h.
- The pressure relief valve needs to be rated for a maximum of 150 psi.
- The discharge piping for the pressure relief valve must be directed so that the hot water cannot splash on anyone or on nearby equipment.
- Attach the discharge tube to the pressure relief valve and run the end of the tube to within 6" from the floor. This discharge tube must allow free and complete drainage without any restrictions.
- If the pressure relief valve installed on the water heater discharges periodically, this may be due to a defective thermal expansion tank or defective pressure relief valve.
- The pressure relief valve must be manually operated periodically to check for correct operation.
- No valve must be placed between the relief valve and the water heater.
- For the ASME model, the pressure relief valve must conform to and be installed in accordance with ASME code.

ELECTRICAL CONNECTIONS

WARNING: Follow the electrical code requirements of the local authority having jurisdiction. In the absence of such requirements, follow the latest edition of the National Electrical Code ANSI/NFPA 70 in the U.S. or the latest edition of CSA C22.1 Canadian Electrical Code, Part 1, in Canada.

CAUTION: When servicing or replacing parts within the water heater, label all wires prior to disconnection to facilitate an easy and error free reconnection. Wiring errors can cause improper and dangerous operation. Verify proper operation after servicing.

1. The water heater must be electrically grounded. Do not attach the ground wire to either the gas or the water piping.
2. The water heater requires **120 VAC / 60 Hz electrical power supply that is properly grounded.**
 - A proper disconnect (i.e. on/off switch, power plug, etc.) controlling the main power to the water heater must be provided for service reasons. (Must comply with local codes).
 - Connect the power supply to the water heater exactly as shown in the wiring diagram;
3. A green screw is provided in the junction box to ground the connection.
4. Can be hardwired or wired to a plug-in.
5. The use of a surge protector is recommended in order to protect the unit from power surges.

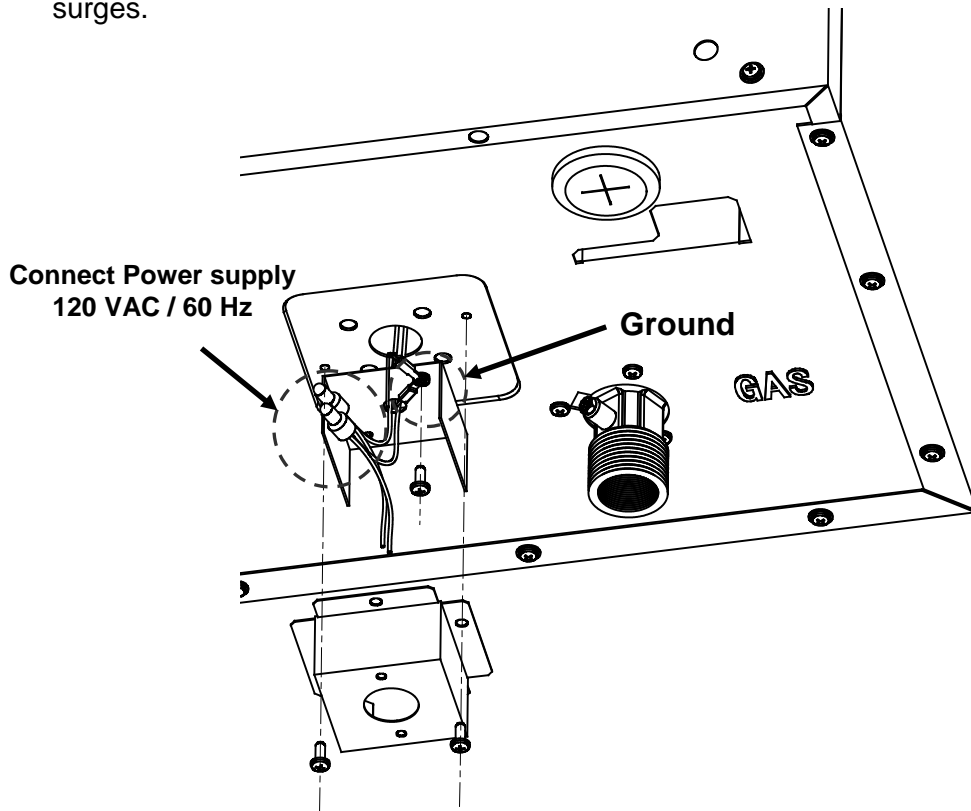

REMOTE CONTROLLER CONNECTION

- 1) Disconnect power supply from the water heater.
- 2) Take off the water heater's front cover.
- 3) Please find the remote control terminal using the diagram below (located around the lower right-hand side of the water heater).
- 4) Open the plastic cover of the remote controller, and then attach the two fork terminals to connector base of the backside of the remote controller with two screws. Make sure the terminals are firmly fixed.
- 5) Put the remote wires through the hole on the bottom of the unit casing.
- 6) Connect the remote wires to the remote controller terminal properly (No polarity).

***Do NOT jump or short-circuit wires, or computer will be damaged.**

- 7) Replace Front Cover securely.
- 8) Wires used for the remote controller connection must be:

- Minimum 20 gauge wire (No polarity)
- Maximum 400 feet long

*For details on the connection to the remote controller accessory, refer to the remote controller Installation Manual.

Remote controller terminals of the water heater

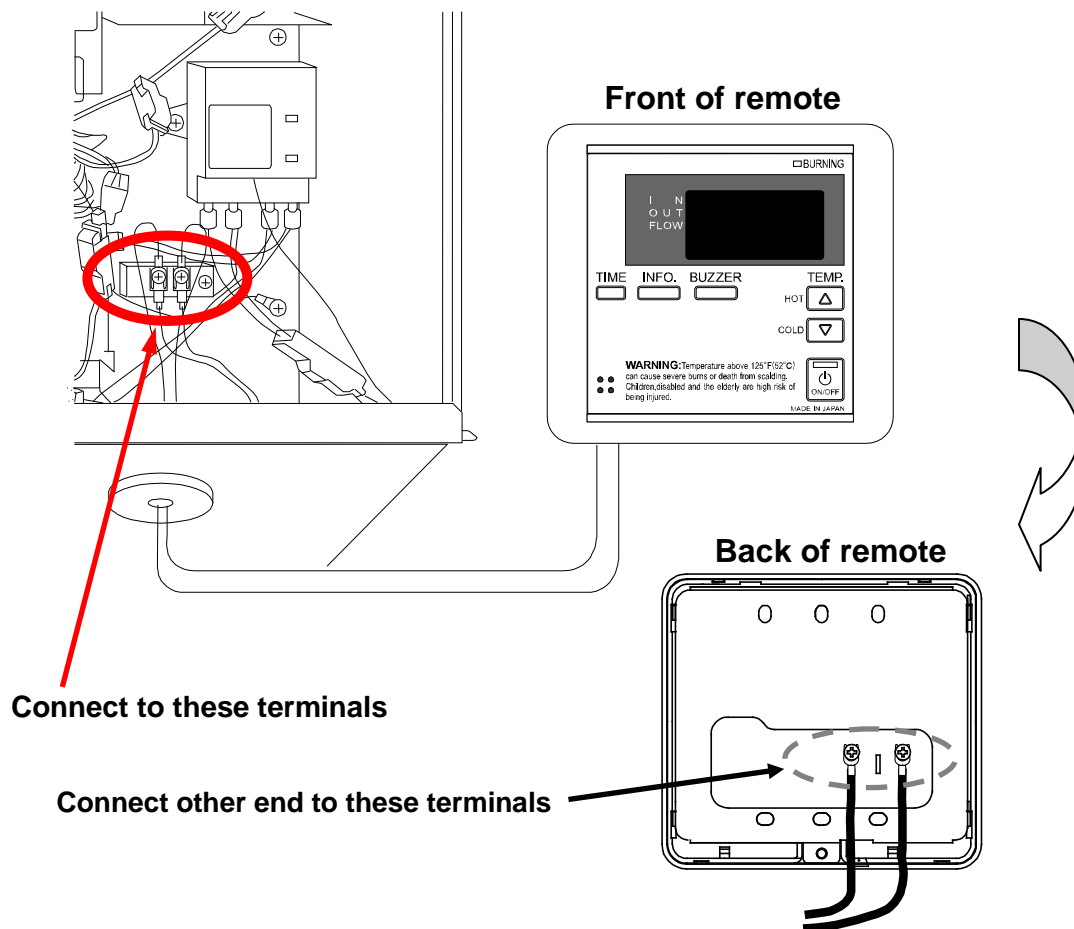

PUMP CONTROL CONNECTIONS

The water heater can be used to control a recirculation pump. **Proper pump control helps to preserve the life of the system and saves energy as well.**

The water heater pump control port is a “**normally-open dry contact**”, and therefore needs additional components to properly control a recirculation pump. To control the recirculation pump, connect the pump to the “**pump terminal**” in the water heater as shown in the diagram below. (In a multi-unit system, connect the pump **ONLY** to the “**PARENT**” unit.) The pump is to be connected using suitable relays shown in the diagram below (**the pump terminal is essentially only a dry contact. An external power supply and relays are required to operate the pump**).

Please make sure the relays are properly rated for the recirculation pump.

Using the water heater’s internal thermistors as a temperature control, the recirculation pump will only turn on when recirculation is needed.



CAUTION: In a multi-unit system, the pump must be connected to the “**Pump**” terminal in the “**PARENT**” unit only. If the pump is connected to any of the “**CHILD**” units, the pump will not work.

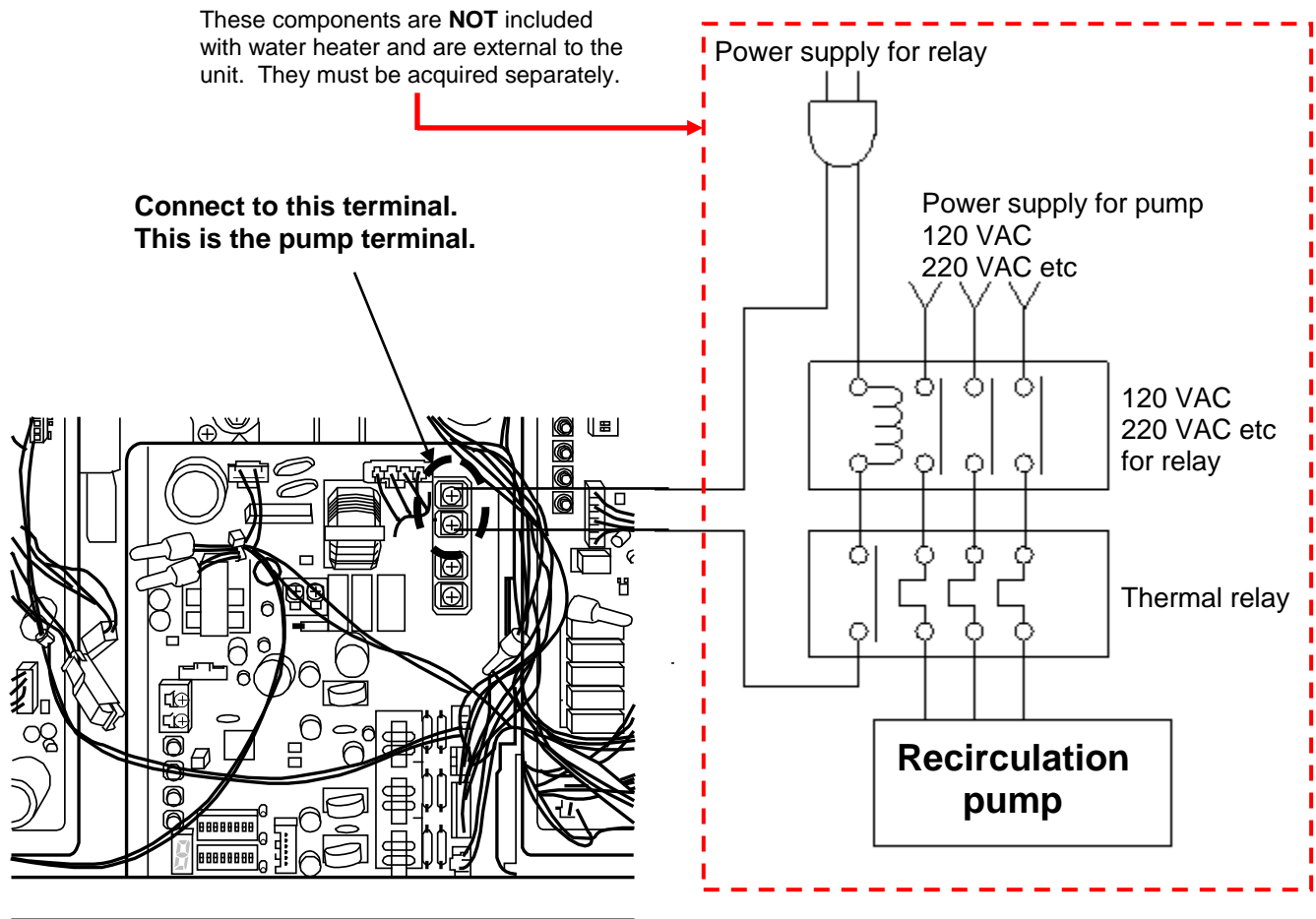

PUMP CONTROL MODE

The water heater provides the four types of the pump control modes. The pump control modes are selected by changing dipswitch settings. The dipswitches are located in the **upper bank** of dipswitches in the lower-left quadrant of the central computer board in the water heater. (See picture below)

A) Recirculation Control: No. 4 ON

This mode is for providing hot water as soon as possible like a recirculation usage. The pump is only made to run while the temperature of the water in the re-circulation loop is not close to the set temperature of the water heater. The pump will run for about 1 minute every 30 minutes to determine whether or not the water temperature in the whole recirculation loop is lower than 9°F from the set temperature. If the water temperature is lower than 9°F from the set temperature, the pump will remain running until the water in the loop gets up to the set temperature. If not, the pump will stop for another 30 minutes. If the inlet thermistor senses that the water temperature is lower than 9°F from the set temperature before those 30 minutes have elapsed, the pump will activate immediately and remain running until the water in the loop gets up to the set temperature.

B) Storage Tank Circulation Control: No.5 ON

The water heater will heat the water 5.4°F higher than its set temperature (unless the water heater is already set at its maximum temperature of 185°F). This is to ensure a higher rate of recovery for storage tank applications. The circulation pump (from storage tank to water heater) will always remain on.

C) Energy Conserving Recirculation: No.4 and No.5 ON

This pump control mode is similar to the "Recirculation Control mode". However, once the heat requirement is less than 7,440 BTU/h, the pump will turn off. The pump will activate again when the temperature of the system is less than 95°F or after 20 minutes have elapsed from its previous operation.

*If operating the pump in this mode, insulation is recommended on the water piping.

D) Normal Control (Default setting): No.4 and No.5 OFF

This provides no ON/OFF control for the pump. If a pump is connected to the pump control terminal and both No.4 and No.5 are OFF, the pump will be made to run all the time as long as there is a power supply to the water heater (If the temperature remote controller is installed, the pump will stop when the remote is turned off). Water in the loop will be maintained at set temperature.

Pump control modes	A) Recirculation Control	B) Storage Tank Circulation Control
	<p style="text-align: center;">1 2 3 4 5 6 7 8</p> <p style="text-align: center;">↑ N</p> <p style="text-align: center;">LP RE-CIR STORAGE P-RE D-PRT</p>	<p style="text-align: center;">1 2 3 4 5 6 7 8</p> <p style="text-align: center;">↑ N</p> <p style="text-align: center;">LP RE-CIR STORAGE P-RE D-PRT</p>
	C) Energy Conserving Recirculation	D) Normal Control (Default)
	<p style="text-align: center;">1 2 3 4 5 6 7 8</p> <p style="text-align: center;">↑ N</p> <p style="text-align: center;">LP RE-CIR STORAGE P-RE D-PRT</p>	<p style="text-align: center;">1 2 3 4 5 6 7 8</p> <p style="text-align: center;">↑ N</p> <p style="text-align: center;">LP RE-CIR STORAGE P-RE D-PRT</p>

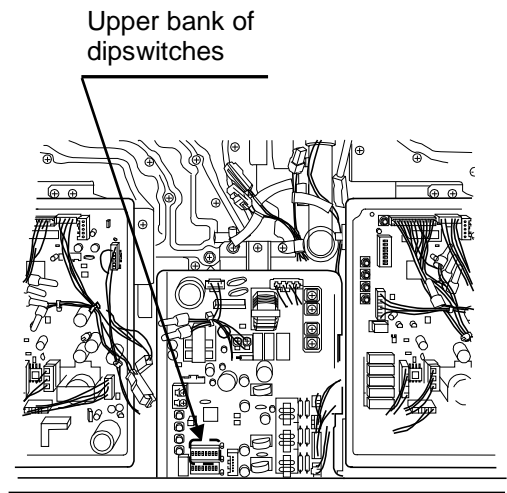

The dark squares indicate the direction the dipswitches should be set to.

EASY-LINK SYSTEM

The water heater can be connected with other heaters of the **same model** with communication cables to work as a multiple manifold system.

- The Easy-Link system can connect up to 4 units.
- A communication cable (gray color) comes with each unit. The cables use 18 gage wire and can be up to 250ft. long all together.

You can manifold from 2 units to 4 units without a multi-system controller. A 4-unit system has full automatic modulation between 15,000 BTU/h and 1,520,000 BTU/h.

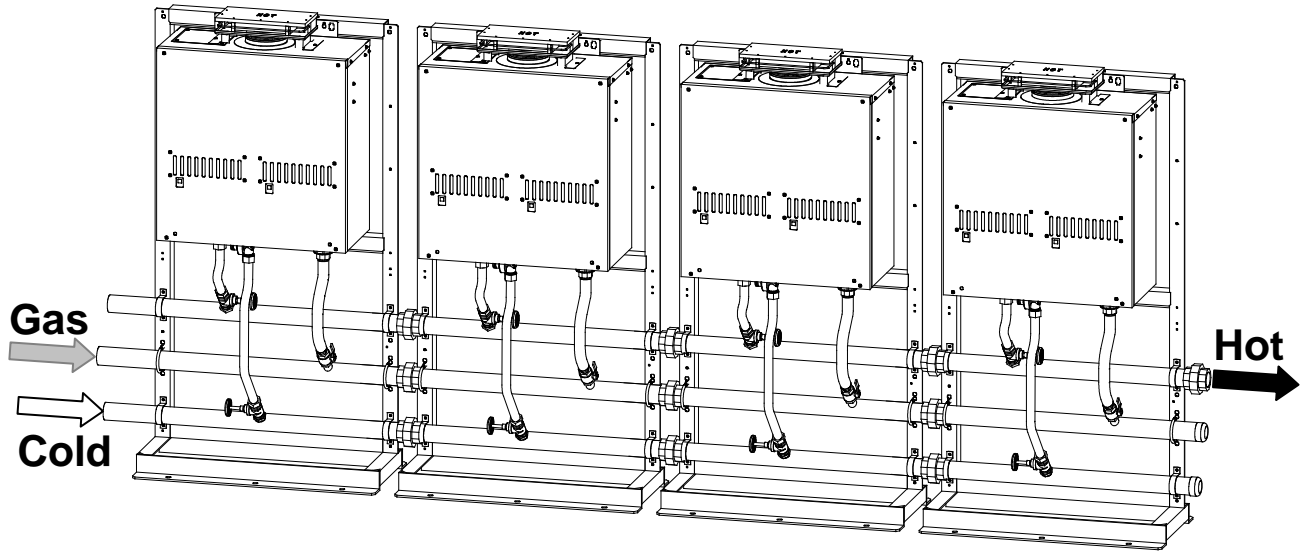



CAUTION

- The Easy-Link system is limited to **4 units**. If you connect more than 4 units, the first 4 units will work as part of the Easy-Link system, but the other additional units will only work as individual units.
- The water heater cannot be linked with other different tankless models in the Easy-Link system and Multi-Unit system.

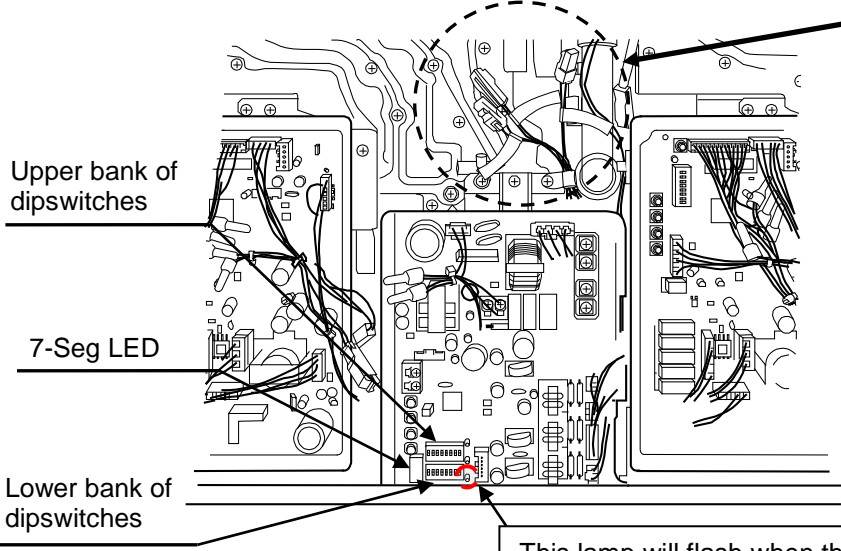

Upper bank of dipswitches

7-Seg LED

Lower bank of dipswitches

Easy-Link / Multi-unit System connectors are on each unit's computer board

To change the dipswitch settings for the Easy-Link system, locate the lower bank of dipswitches to the right of the 7-seg LED. **Do not adjust the upper bank of dipswitches.**

This lamp will flash when the unit is allowed the operation.

Easy-Link Connection Procedures

1. Choose one of your units as the “PARENT” unit.

2. “The PARENT”

Locate the **lower bank** of dipswitches to the right of the 7-seg. LED on the **central computer board** of the unit that you select to be the “PARENT” unit. Change dipswitch No. 8 to “ON”. Do not change any of the dipswitches on the “CHILD” units.

3. Between the “PARENT” and the “CHILD-1”

Connect the “PARENT connector” of the “PARENT” unit to the “[1] connector” of the “CHILD-1” unit.

4. Between the “CHILD-1” and the “CHILD-2”

Connect the “[2] connector” of the “CHILD-1” unit to the “[1] connector” of the “CHILD-2” unit.

5. Between the “CHILD-2” and the “CHILD-3”

Connect the “[2] connector” of the “CHILD-2” unit to the “[1] connector” of the “CHILD-3” unit.

6. Make sure the 7-seg. LED of all the unit’s computer boards display the unit #. The numbering system automatically allocates the unit # to each water heater in the Easy-Link system, in accordance with the table below.

PARENT unit	Unit # : 1	The dark squares indicate the direction the dipswitches should be set to.
CHILD units	Unit# : 2, 3 and 4	

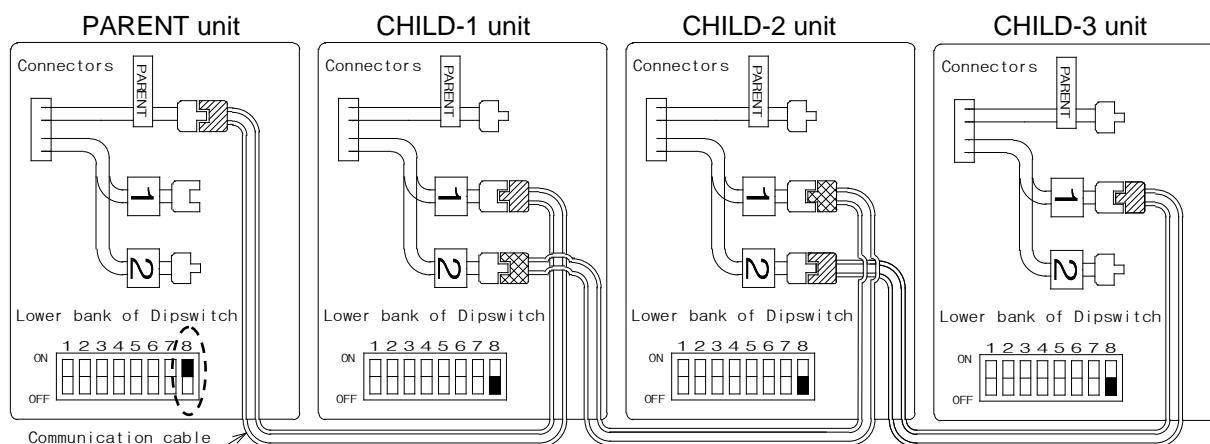

CAUTION

- Unless you change dipswitch No. 8 of the “PARENT” unit to “ON”, the system will not work as an Easy-Link system. The units will work as individual units.



Wrong dipswitch setting on the “PARENT” unit

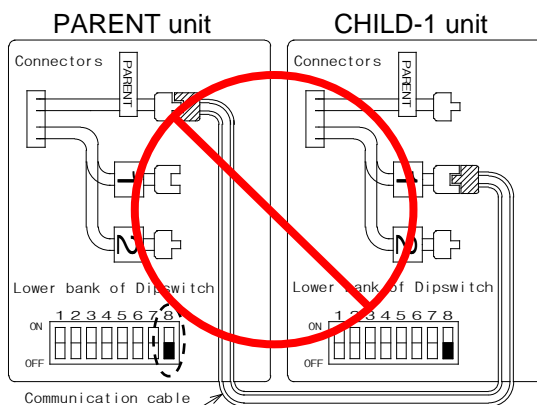

CAUTION

- If you connect the “[1] (or [2]) connector” of the “PARENT” unit to the “PARENT (or [1]) connector” of the “CHILD-1” unit, the system will not work as the Easy-Link system. The units will operate as individual units.



Wrong connection between the “PARENT” unit and the “CHILD-1” unit

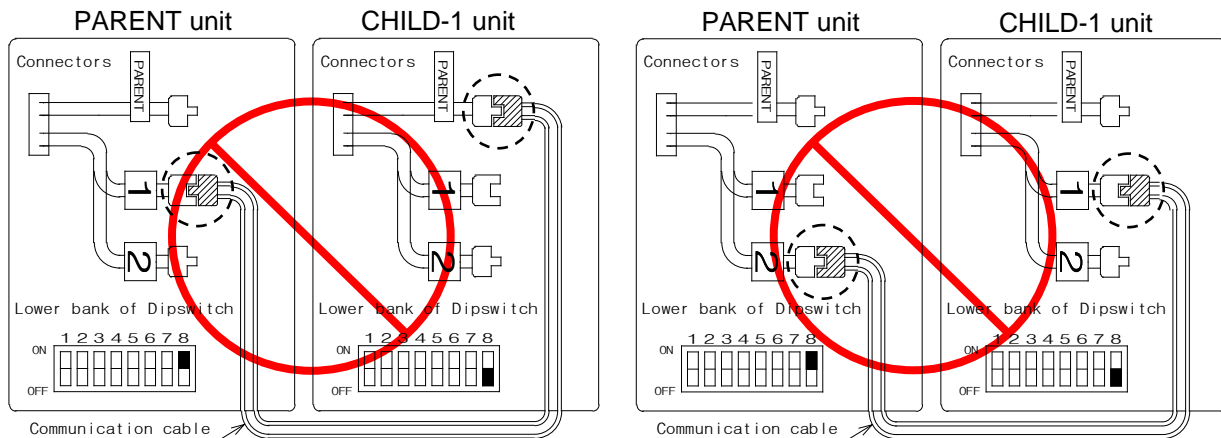

- If you connect the “PARENT connector” of the “CHILD-1” unit to the “[1] connector” of the “CHILD-2” unit, the “CHILD-2” unit will work as an individual unit, and will not be part of the Easy-Link system.



Wrong connection between the “CHILD-1” unit and the “CHILD-2” unit

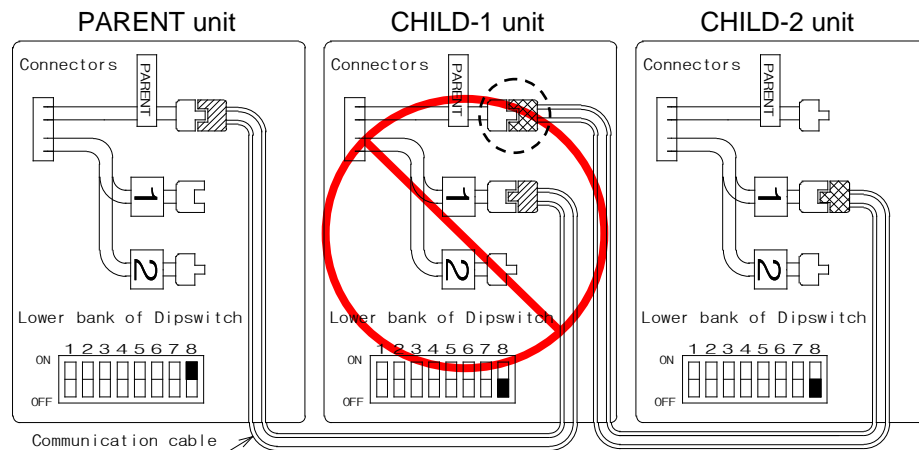

WARNING

Connecting two “PARENT connectors” together from two separate units **may damage the computer board**. The communication cable has a female end and a male end so it's impossible to have a PARENT -to- PARENT connection with the communication cable. Do not splice or modify connectors.



Prohibited

- If a remote controller (optional) is used, it has to be connected to the “**PARENT**” unit. If the remote controller is connected to a “**CHILD**” unit, it will only control that particular individual “**CHILD**” unit and will not control the Easy-Link system as a whole.

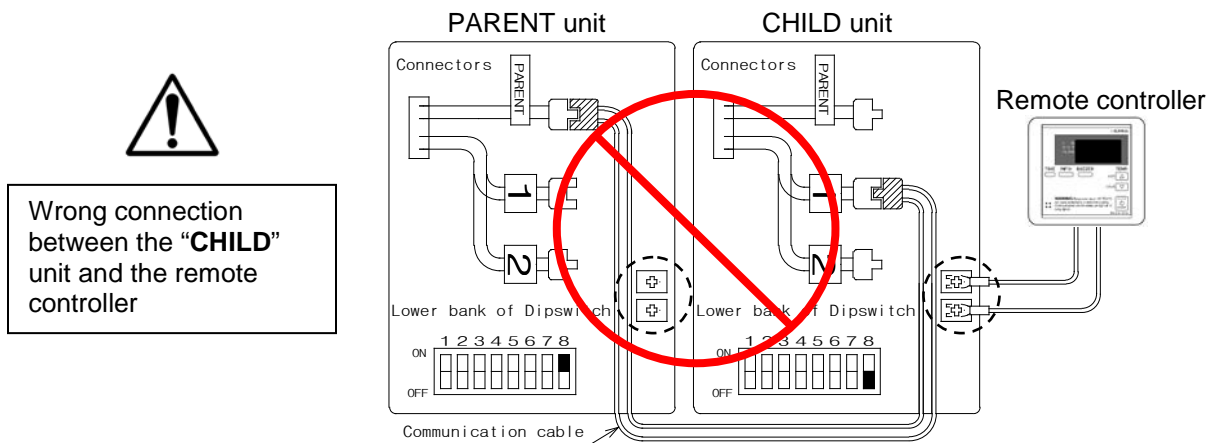

- The remote controller is not required for the Easy-Link system.
- If running the Easy-Link system without the remote controller, please make sure the dipswitch settings for the temperature, outdoor, and direct-vent settings on ALL the units are set to the same settings. Otherwise, the units may not operate properly.
- If the remote controller is used, the temperature on all the units in the system will automatically be set to the same temperature that is set on the remote. However, even with the remote, the outdoor and direct-vent dipswitch settings still need to be set to the same settings on all the units.

MULTI-UNIT SYSTEM FOR LARGE VOLUMES

Multi-Unit system allows 910 (T-M50) model to be combined together from two to 10 units with the multi-unit controller and remote controller for commercial or residential applications. For a 10-unit system, the computer can modulate from 15,000 BTU/h to 3,800,000 BTU/h.

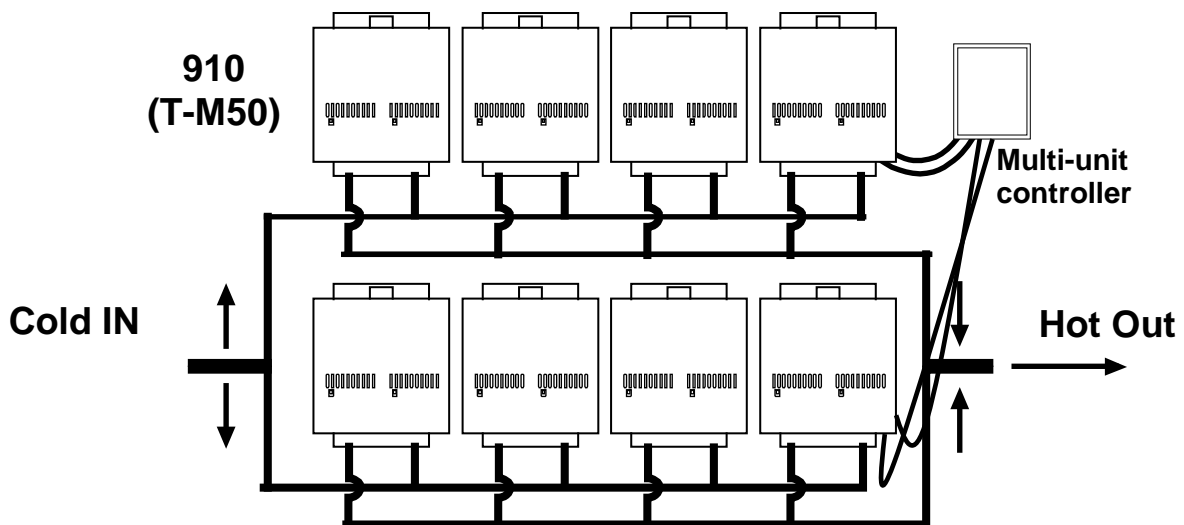

An individual cut-off switch is recommended for each unit in a multi-unit system for the purpose of maintenance.

Multi-Unit System Connection Diagram

The water heaters with a multi-unit controller and a remote controller wiring:

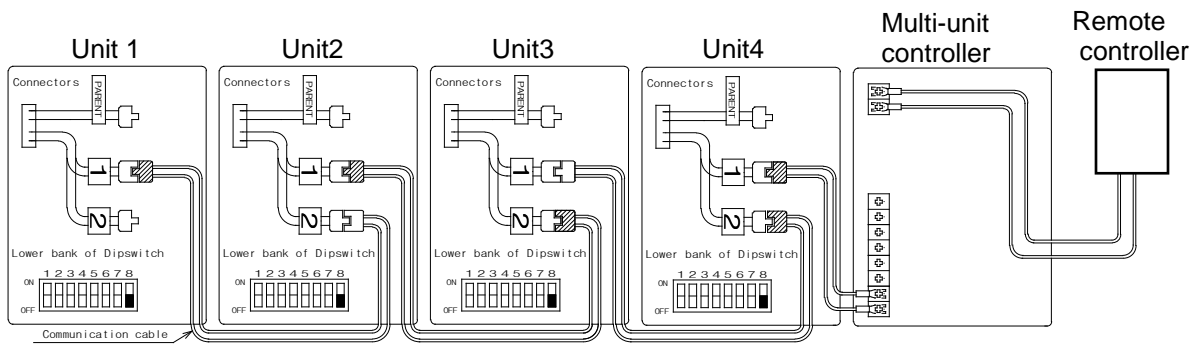

- The above connection diagram is an example of how to connect 4 water heaters together in a Multi-Unit System. Up to 10 water heaters can be connected in this fashion.
- Make sure the “7-seg LED” of computer board of each unit displays the unit #. The multi-unit controller automatically allocates the unit # (1 to 10) to each water heater in a Multi-Unit system.
- The dark squares indicate the direction the dipswitches should be set to.

Available multi-unit controllers with a remote controller	
9007675005 (TM-MC01) (comes with 9007603005 (TM-RE30))	9008300005 (TM-MC02) (comes with 9008172005 (TM-RE40))

Please refer to the multi-unit controller’s manual for additional information and instruction.

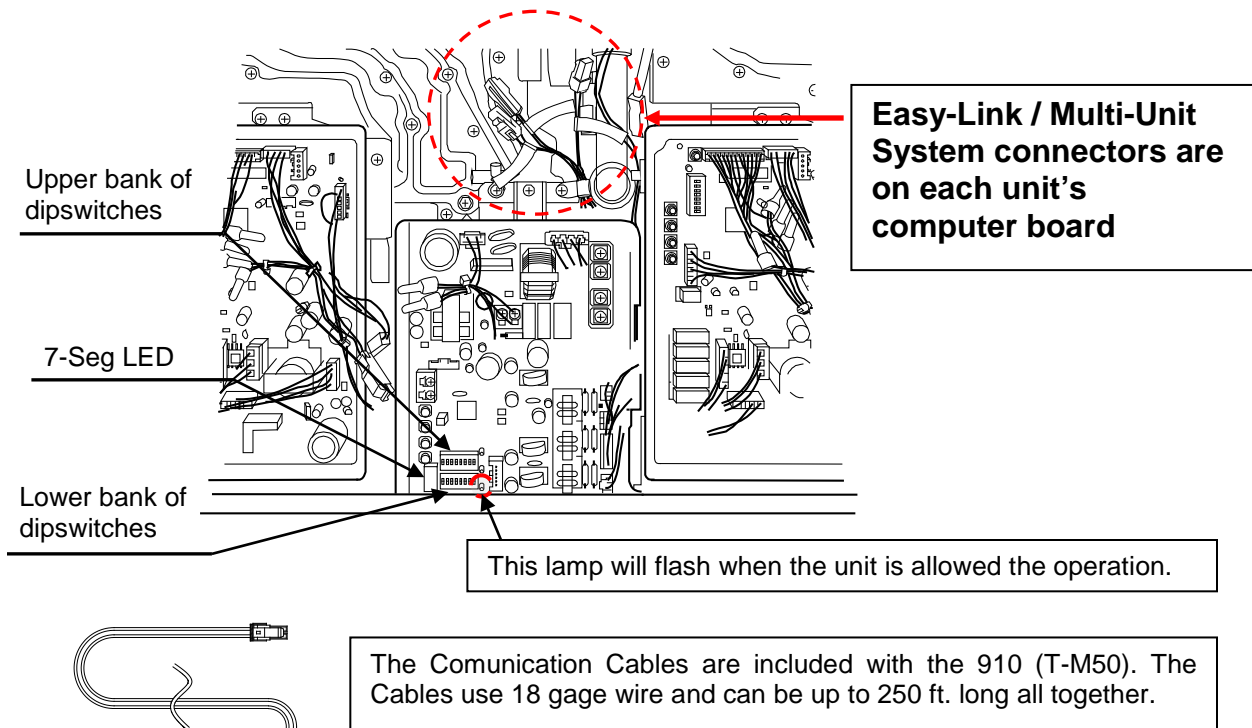

INITIAL OPERATION

FOR YOUR SAFETY, READ BEFORE OPERATING:

- **Check the GAS and WATER CONNECTIONS** for leaks before firing it for the first time.
- Open the main gas supply valve to the unit using only your hand to avoid any spark. Never use tools. If the knob will not turn by hand, do not try to force it; call a qualified service technician. Forced repair may result in a fire or explosion due to gas leaks.
- Be sure to check next to the bottom of the unit because some gases are heavier than air and may settle towards the floor.
- **Check the GAS PRESSURE.** Refer to p.16.
- Do not try to light the burner manually. It is equipped with an electronic ignition device which automatically lights the burner.
- **Check for PROPER VENTING and COMBUSTIBLE AIR** to the heater.
- **Purge the GAS and WATER LINES** to remove any air pocket.
- Do not use this water heater if any part has been submersed under water. Immediately call a qualified service technician to inspect the water heater and to replace any damaged parts.

CAUTION: IF YOU SMELL GAS:

- Do not try to start the water heater.
- Do not touch any electric switch; do not use any phone in your building.
- Immediately call your gas supplier from a neighbor's phone. Follow the gas supplier's instructions.
- If you cannot reach your gas supplier, call the fire department.

1. Once the above checks have been completed, please clean filter of any debris. Refer to p. 34 for instructions.



2. Fully open the manual water control valve on the water supply line.



3. Open a hot water tap to verify that water is flowing to that tap.

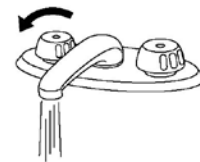

Then close the hot water tap.

4. Fully open the manual gas control valve installed.



5. Turn on the 120 volt 60 Hz power supply to the water heater.

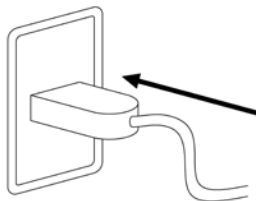

6. Now you are ready to enjoy hours of endless hot water.

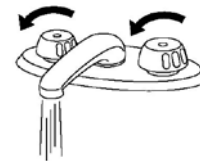

NORMAL OPERATION



- Flow rate to activate the 910 (T-M50) : 0.5 gallon per minute
- Flow rate to keep the 910 (T-M50) running : 0.4 gallon per minute

WITHOUT REMOTE CONTROLLER

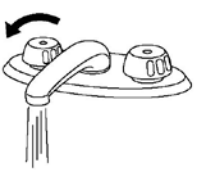
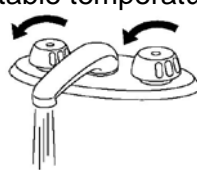
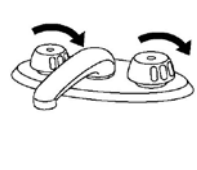
<p>1. Open a hot water tap.*</p> 	<p>2. Mix cold water with the hot to get the suitable temperature water.</p> 	<p>3. Close the hot water tap.</p> 
--	--	--

WITH REMOTE CONTROLLER INSTALLED: 9007603005 (TM-RE30) (Optional)

1. Press the power ON/OFF button.

2. Press the HOT/COLD button to set the water temperature up to 120 °F (50 °C).

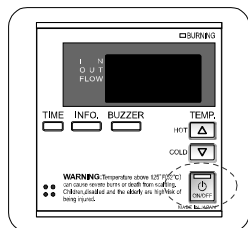

When ON, green LED is lit.

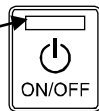

The temperature and the time will be displayed on the remote controller.

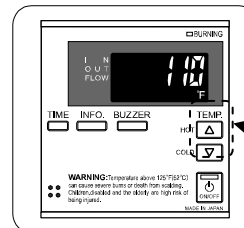

(EX: 110°F)

TEMP.

HOT



COLD



Increasing temperature from 120 °F (50 °C) to 140 °F (60 °C)

- Press the “HOT” button to set 120 °F (50 °C).
- Press and hold the “INFO” button and the “HOT” button for at least 3 seconds. The remote will emit a beep and change to 125 °F (52 °C).
- Press the “HOT” button to set up to 140 °F (60 °C).

Increasing temperature above 140 °F (60 °C)

- Press the “HOT” button to set 140 °F (60 °C).
- Press and hold the “INFO” button and the “HOT” button for at least 3 seconds. The remote will emit a beep and change to 145 °F (63 °C).
- Press the “HOT” button to set up to 175 °F (80 °C) or 185 °F (85 °C).

Temperatures available under the Default Mode

(Unit: °F)

100	105	110	115	120	125	130	135	140	145	150	155	160	165	170	175
-----	-----	-----	-----	-----	-----	-----	-----	-----	-----	-----	-----	-----	-----	-----	-----

Temperatures available under the High Temperature Mode* (Refer to p. 31 for details.)

(Unit: °F)

110	115	120	125	130	135	140	145	150	155	160	165	170	175	180	185
-----	-----	-----	-----	-----	-----	-----	-----	-----	-----	-----	-----	-----	-----	-----	-----

3. Open a hot water tap.

Mix cold water with the hot if you need.

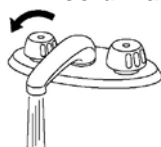

Lamp is ON

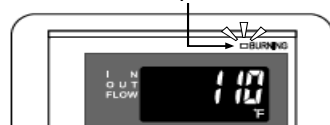

4. Close the hot water tap.



Lamp is OFF

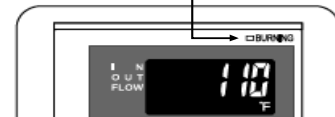

WARNING

Hot Water temperatures over 125 °F (52 °C) can cause severe burns instantly or death from scalding.

- The outlet hot water temperature of the water heater is factory set at 120 °F (50 °C).
- Feel the water temperature before bathing or showering.

***To change the remote controller's mode from Default Mode to High Temperature Mode, please follow the procedures below (the remote controller must be installed prior to operating these procedures):**



DO NOT set to 185°F if you use your water heater in a recirculation system. This will cause damage to the heater and void the warranty.

1. Turn off power to the remote controller by pressing the **"ON/OFF"** button.



Lamp is OFF to indicate that power is off

2. Simultaneously press and hold both the **"HOT"** and **"COLD"** buttons for at least five seconds. And then make sure "1" (or "0") is displayed on remote controller.
"1" is displayed for single units "0" is displayed for Easy-Link / Multi-unit Systems

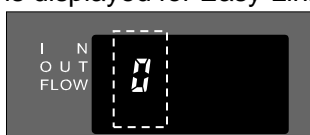

3. Press the **"TIME"** button.
Make sure OFF and F1 are displayed on remote controller.



4. Press the **"INFO"** button. After, make sure "OFF" blinks.

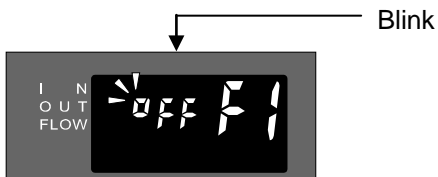

5. Press the **"HOT"** button or the **"COLD"** button to set display to "on".

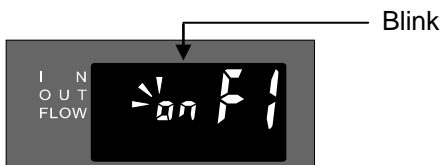

6. Simultaneously press both the **"BUZZER"** button and the **"INFO"** button to fix the setting.
7. Make sure display is no longer blinking.

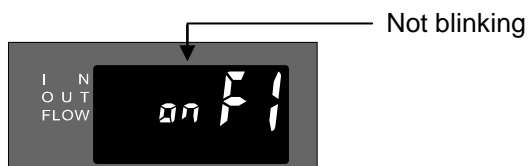

8. Press the **"ON/OFF"** button to finish the setting.
9. Turn on power to the remote controller by pressing the **"ON/OFF"** button again.



Lamp is ON

FLOW

- The flow rate through the water heater is limited to a maximum of 14.5 GPM.
- The temperature setting, along with the supply temperature of the water will determine the flow rate output of the unit.
- Please refer to the temperature vs. gallons per minute chart on p.51 to determine the likely flow rates based on your local ground water temperature and your desired outlet water temperature combination.
- Based on the United States Department of Energy method of testing water heater output, the water heater is rated for 474 gallons per hour (GPH) or 7.9 gallons per minute (GPM) for Natural Gas, and 504 GPH or 8.4 GPM for Liquid Propane, when raising the water temperature by 77°F (from 58°F to 135°F).
- Refer to the chart on the right for typical household plumbing fixture flow rates to determine what the water heater can do in a household application.

Household Flow Rates	
Appliance / Use	Flow Rate (GPM)
Lavatory Faucet	1.0
Bath Tub	4.0 – 10.0
Shower	2.0
Kitchen Sink	1.5
Dishwasher	1.5
Washing Machine	4.0

Taken from UPC 2006

FREEZE PROTECTION SYSTEM

- This unit comes equipped with heating blocks to protect it against damages associated with freezing.
- For this freeze protection system to operate, there has to be electrical power to the unit. Damage to the heat exchanger caused by freezing temperatures due to power loss is not covered under the warranty. In cases where power losses can occur, consider the use of a backup power supply.
- The freeze protection system will activate when the surrounding and/or outside temperatures drop below 36.5°F (2.5°C).
- In any areas subject to freezing temperatures, the manufacturer highly recommends installing the unit indoors. In such an installation, freezing issues can only occur if cold air enters through the venting into the heat exchanger, whether by negative pressures within the installation location or by strong outside winds. It is the installer's responsibility to be aware of these issues and take all preventative measures. The manufacturer will not be responsible for any damage to the heat exchanger as a result of freezing.
- The manufacturer also highly recommends the use of a backflow preventer (sold separately) to minimize the amount of cold air entering through the exhaust venting when the water heater is off.
- If you will not be using your heater for a long period of time:
 1. Completely drain the water out of the unit. Refer to p. 34.
 2. Disconnect power to your heater.

This will keep your unit from freezing and being damaged.

CAUTION: Only pipes within the water heater are protected by the freeze protection system. Any water pipes (hot or cold) located outside the unit will not be protected. Properly protect and insulate these pipes from freezing.

TEMPERATURE SETTINGS

- The temperature has been preset at the factory to 120 °F (50 °C).
- There are 8 preset temperatures that you can select from by changing the dipswitch settings on the computer board. If you want to change the set temperature with dipswitches, please refer to the diagram below. These temperatures are available: 100 °F, 115 °F, 120 °F, 135 °F, 145 °F, 155 °F, 165 °F, and 185 °F.
- If you need more detailed temperature settings other than the 8 preset settings, please purchase the optional temperature remote controller (part No. 9007603005 (TM-RE30)). With this optional remote controller you can set the temperature in increments of 5 °F from 100 °F to 185 °F. Refer to p. 30. Please read the instructions carefully prior to installing the remote controller, as failure to do so could damage the temperature controller and/or the water heater, which will void the warranty.



- Turn off the power supply to the heater before changing the dipswitch settings.
- Only change the switches with the dark squares. The dark squares indicate which direction the dipswitch should be set to.
- DO NOT set to 185°F if you use your water heater in a recirculation system. This will cause damage to the heater and void the warranty.

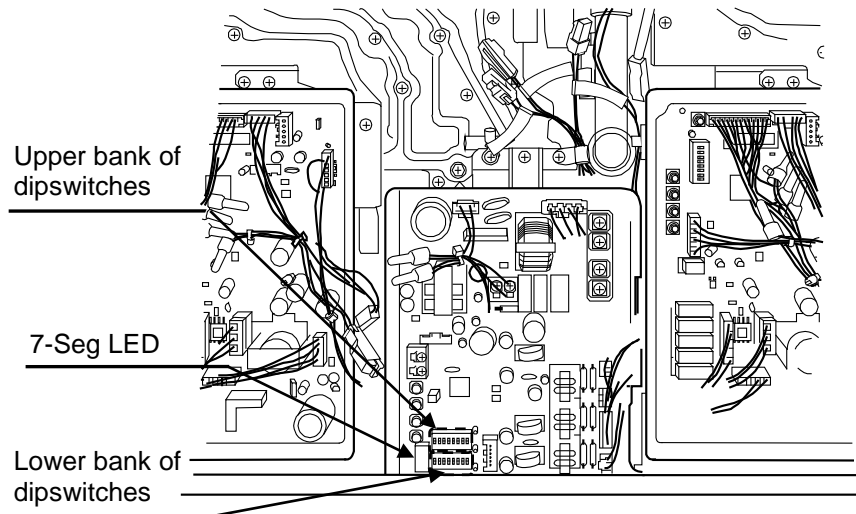

To change dipswitch settings for temperatures, locate the lower bank of dipswitches to the right of 7-Seg LED. DO NOT adjust the upper bank of dipswitches.

The dark squares indicate the direction the dipswitches should be set to.

Temperature Settings <Lower bank of dipswitches>

100°F (38 °C)	115°F (46 °C)	120°F (50 °C) DEFAULT	135°F (57 °C)
145°F (63 °C)	155°F (68 °C)	165°F (74 °C)	185°F (85 °C)

MAINTENANCE AND SERVICE



WARNING: Turn off the electrical power supply and close the manual gas control valve and the manual water control valve before servicing.

- Clean the cold-water inlet filter. (Refer to diagram below)
- Be sure that all openings for combustion and ventilation air are not blocked.
- The venting system should be checked annually for any leaks, corrosion, blockages or damage.
- The burner should be checked annually for dust, lint, grease or dirt.
- Keep the area around the water heater clear. Remove any combustible materials, gasoline or any flammable vapors and liquids.
- In accordance with all local codes and common safety practices, Water discharged from the pressure relief valve can cause severe burns instantly from scalding. **DO NOT** touch the pressure relief valve.
- If the relief valve discharges periodically, it may be due to thermal expansion in a closed water supply system. Contact the water supplier or local plumbing inspector on how to correct this situation.
- Visual check of burner flames (see below) through the burner window in the burner assembly located at the middle of the water heater.

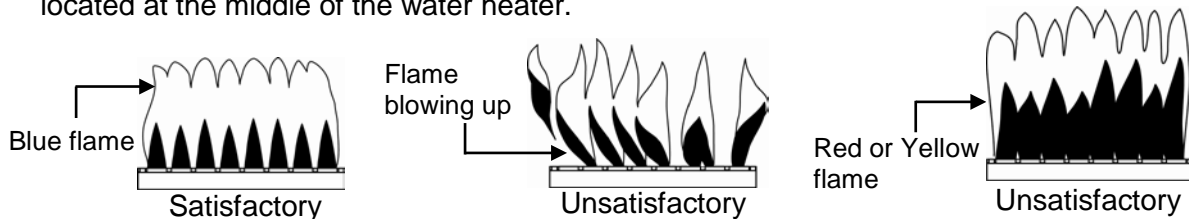

The manufacturer recommends having the unit checked once a year or as necessary by a licensed technician. If repairs are needed, any repairs should be done by a licensed technician.

UNIT DRAINING and FILTER CLEANING

1. Close the manual gas shut off valve.
2. Turn off power to the unit, and then turn on again.
3. Wait 30 seconds, and then turn off power to the unit, yet again.
4. Close the water shut off valve.
5. Open all hot water taps in the house. When the residual water flow has ceased, close all hot water taps.
6. Have a bucket or pan to catch the water from the unit's drain plugs. **Unscrew** the drain plugs to drain all the water out of the unit.
7. Wait a few minutes to ensure all water has completely drained from unit.
8. **Clean the filter:** Check the water filter located within the cold inlet. With a tiny brush, clean the water filter of any debris which may have accumulated and reinsert the filter back into the cold water inlet.
9. Securely screw the drain plugs back into place. **Hand-tighten only.**

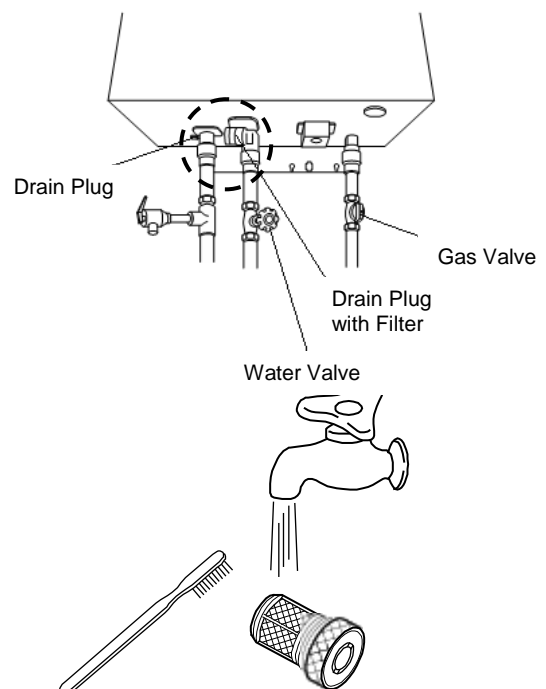

GENERAL TROUBLESHOOTING

~ TEMPERATURE and AMOUNT OF HOT WATER ~	
PROBLEM	POSSIBLE SOLUTIONS
It takes long time to get hot water at the fixtures.	<ul style="list-style-type: none"> • The time it takes to deliver hot water from the water heater to your fixtures depends on the length of piping between the two. The longer the distance or the bigger the pipes, the longer it will take to get hot water. • If you would like to receive hot water to your fixtures quicker, you may want to consider a hot water recirculation system. (p. 40)
The water is not hot enough.	<ul style="list-style-type: none"> • Compare the flow and temperature. See the chart on p. 51. • Check cross plumbing between cold water lines and hot water lines. • Is the gas supply valve fully open? (p. 29) • Is the gas line sized properly? (p. 17) • Is the gas supply pressure enough? (p. 16) • Is the set temperature set too low? (p. 30,33)
The water is too hot.	<ul style="list-style-type: none"> • Is the set temperature set too high? (p. 30,33)
The hot water is not available when a fixture is opened.	<ul style="list-style-type: none"> • Make sure the unit has 120 VAC / 60 Hz power supply. • If you are using the remote controller, is the power button turned on? (p. 30) • Is the gas supply valve fully open? (p. 29) • Is the water supply valve fully open? (p. 29) • Is the filter on cold water inlet clean? (p. 34) • Is the hot water fixture sufficiently open to draw at least 0.5 GPM through the water heater? (p. 30) • Is the unit frozen? • Is there enough gas in the tank / cylinder? (for Propane models)
The hot water gets cold and stays cold.	<ul style="list-style-type: none"> • Is the flow rate enough to keep the water heater running? (p. 30) • If there is a recirculation system installed, does the recirculation line have enough check valves? • Is the gas supply valve fully open? (p. 29) • Is the filter on cold water inlet clean? (p. 34) • Are the fixtures clean of debris and obstructions?
Fluctuation in hot water temperature.	<ul style="list-style-type: none"> • Is the filter on cold water inlet clean? (p. 34) • Is the gas line sized properly? (p. 17) • Is the supply gas pressure enough? (p. 16) • Check for cross connection between cold water lines and hot water lines.

~ WATER HEATER ~

PROBLEM	POSSIBLE SOLUTIONS
Unit does not ignite when water goes through the unit.	<ul style="list-style-type: none"> • Is the flow rate over 0.5 GPM? (p. 30) • Check for the filter on cold water inlet. (p. 34) • Check for reverse connection and cross connection. • If you use the remote controller, is the power button turned on? (p. 30)
The fan motor is still spinning after operation has stopped.	<ul style="list-style-type: none"> • This is normal. After operation has stopped, the fan motor keeps running for 35 seconds in order to re-ignite quickly, as well as push all exhaust gas out of the flue.
Abnormal sounds come from the unit.	<ul style="list-style-type: none"> • Contact the manufacturer at 1-877-737-2840.

**~ REMOTE CONTROLLER: 9007603005
(TM-RE30) (OPTIONAL) ~**

PROBLEM	POSSIBLE SOLUTIONS
Remote controller does not display anything when the power button is turned on.	<p>Press the ON/OFF button.</p> <p>If the lamp lights up ⇒</p> <ul style="list-style-type: none"> • This is normal. When the unit has not operated for five minutes or more, the display turns off to conserve energy. <p>If the lamp does not light ⇒</p> <ul style="list-style-type: none"> • Make sure the unit gets power supply. • Make sure the connection to the unit is correct.(p. 21)
An ERROR code is displayed.	<ul style="list-style-type: none"> • Please see the p. 37.

~ EASY-LINK SYSTEM ~

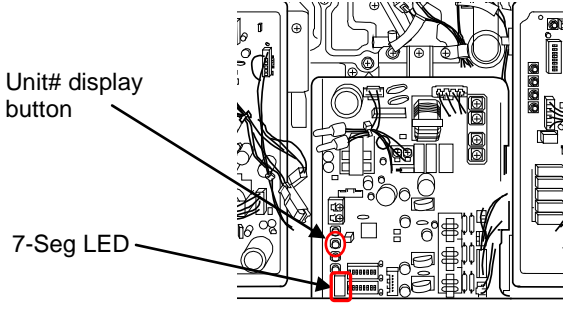
PROBLEM	POSSIBLE SOLUTIONS
How are the unit numbers assigned?	<ul style="list-style-type: none"> • For an Easy-Link system, other than the Parent Unit (which is always labeled #1), all the other units (the Child units) are numbered randomly. • To check which numbers are assigned to which units, push the button on the computer board of a unit as shown below. The unit number will be displayed on the 7-Seg LED. <div style="text-align: center;">  <p>The diagram shows a close-up of a computer board with various components. A red box highlights a small button labeled 'Unit# display button' and a 7-segment LED display labeled '7-Seg LED' next to it. Arrows point from the text labels to these components.</p> </div>

TROUBLESHOOTING – ERROR CODES

- The units are self diagnostic for safety and convenience when trouble shooting.
- If there is a problem with the installation or the unit, it will display a numerical error code on the remote controller (if installed) or on the 7-Seg LED of the central computer board and section computer board to communicate the source of the problem.
- Consult the following chart for the cause of each error code.

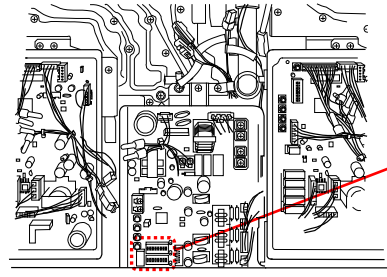

7-Seg LED

The top red lamp will flash when the right combustion section has an error code.

The mid red lamp will flash when the left combustion section has an error code.



Remote controller (Optional)

Error Code	Malfunction description	Error Code	Malfunction description	Error Code	Malfunction description
031	Incorrect dipswitch setting	391	Air-fuel Ratio Rod failure	661	Water Control Valve Fault (Bypass function)
101	Warning for 991 error code	441	Flow Sensor Failure	681	Abnormal External Fan motor
111	Ignition failure	510	Abnormal Main Gas Valve	701	Computer board Fault
121	Loss of flame	551	Abnormal Gas Solenoid Valve	721	False Flame Detection
311	Output thermistor failure	611	Fan Motor Fault	741	Miscommunication between water heater and remote controller
321	Inlet thermistor failure	631	Abnormal External Pump	761	Miscommunication in Easy-Link OR Multi-unit system
331	Mixing thermistor failure	651	Water Control Valve Fault (Flow Adjustment function)	991	Imperfect combustion

Single Unit

- The 7-Seg LED displays the 3-digit error codes one digit at a time. The remote controller (if installed) displays the whole 3-digit error code at once.
- When the right and/or left combustion section has an error code, the red lamp next to the 7-Seg LED on the central computer board will flash to indicate which combustion section has the error code. Refer to the above picture.

Example:

If your unit has the “321” error code (inlet thermistor),

- The 7-Seg LED, will flash the 3-digit error code one digit at a time. The 7-Seg LED will display “3”... “2”... “1”, and then repeat the 3 digits.
- The remote controller, however, will display “321” on its screen, in its entirety.

Easy-Link

- The 7-Seg LED on the PARENT unit displays a 5-digit number to signify which unit in the Easy-Link system has the error, and what the error code is. The 7-Seg LED displays the number one digit at a time.
- The remote controller (if installed) displays a 3-digit number which also signifies which unit has the error, and what the error code is.
- The unit that has the error in an Easy-Link system will display the error code on its 7-Seg LED in exactly the same way as if it were only a Single Unit.
- When the right and/or left combustion section has an error code, the red lamp next to the 7-Seg LED on the central computer board will flash to indicate which combustion section has the error code. Refer to the above picture.

Example:

If Unit #2 has the “321” error code (inlet thermistor),

- The 7-Seg LED on the PARENT unit will display “3”... “2”... “1”... “0”... “2”, displaying only one digit at a time. The first 3 numbers indicate the error code. The last two numbers indicate that Unit #2 has the error.
- The remote controller, however, will display “232” on its screen in its entirety. The first “2” indicates that Unit #2 has the error. The “32” indicates the first two digits of the “321” error code.
- The 7-Seg LED on Unit #2 will display “3”... “2”... “1”, just like in the Single Unit example.

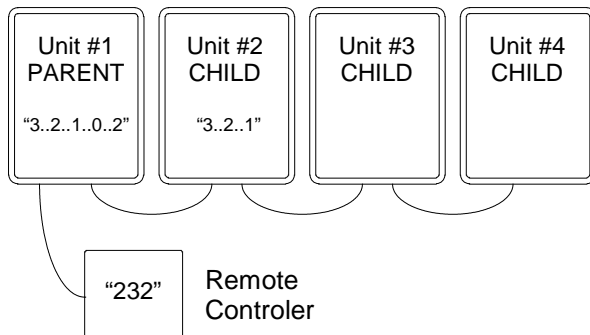

OPERATING SAFETY

FOR YOUR SAFETY READ BEFORE OPERATING

WARNING: If you do not follow these instructions exactly, a fire or explosion may result causing property damage, personal injury or loss of life.

- A. This water heater does not have a pilot. It is equipped with an ignition device that automatically lights the burner. Do not try to light the burner by hand.
- B. BEFORE OPERATING smell all around the water heater area for evidence of leaking gas. Be sure to smell next to the floor because some gas is heavier than air and will settle on the floor.

WHAT TO DO IF YOU SMELL GAS.

- Do not try to light any appliance.
 - Do not touch any electric switch, do not use any phone in your building.
 - Immediately call your gas supplier from a neighbor's phone. Follow the gas supplier's instructions.
 - If you cannot reach your gas supplier, call the fire department.
- C. Use only your hand to turn the gas valve knob. Never use tools. If the knob will not turn by hand, don't try to repair it. Call a qualified service technician. Forced or attempted repair may result in a fire or explosion.
 - D. Do not use this water heater if any part has been under water. Immediately call a qualified service technician to inspect the water heater and to replace any damaged parts.

OPERATING INSTRUCTIONS

1. **STOP!** Read the safety information above or in the Owners Manual.
2. Turn off all electric power to the water heater.
3. Do not attempt to light the burner by hand.
4. Turn the manual gas valve located on the outside of the unit clockwise ⤵ to the off position.
5. Wait five (5) minutes to clear out any gas. If you then smell gas. STOP! Follow "B" in the safety information above on this label. If you don't smell gas, go to next step.
6. Turn the manual gas valve located on the outside of the unit counter clockwise ⤴ to the ON position.
7. Turn on all electrical power to the water heater.
8. If the water heater will not operate, follow the instructions "to Turn Off Gas to water heater" and Call your service technician or gas supplier.

TO TURN OFF GAS TO APPLIANCE

1. Turn off all electric power to the water heater if service is to be performed.
2. Turn the manual gas valve located on the outside of the unit clockwise ⤵ to the off position.

DANGER



Vapors from flammable liquids will explode and catch fire causing death or severe burns.

Do not use or store flammable products such as gasoline, solvents or adhesives in the same room or area near the water heater.

Keep flammable products:

1. Far away from heater
2. In approved containers
3. Tightly closed
4. Out of children's reach

Vapors:

1. Cannot be seen
2. Vapors are heavier than air
3. Go a long way on the floor
4. Can be carried from other rooms to the main burner by air currents

WARNING: Do not install water heater where flammable products will be stored.

Read and follow water heater warnings and instructions. If owner's manual is missing, contact the retailer or manufacturer.

WARNING

The outlet hot water temperature of the water heater is factory set at 120 °F (50 °C). Use this heater at your own risk. The set outlet water temperature can cause severe burns instantly or death from scalds. Test the water before bathing or showering. Do not leave children or an infirm person in the bath unsupervised.

DANGER



Hot Water Heater temperature over 125 °F (52 °C) can cause severe burns instantly or death from scalding. Children, disabled and elderly are at the highest risk of being scalded. Feel water temperature before bathing or showering. Temperature limiting valves are available. Ask a professional person.

WARNING: California Proposition 65 lists chemical substances known to the state to cause cancer, birth defects, death, serious illness or other reproductive harm. This product may contain such substances, be their origin from fuel combustion (gas, oil) or components of the product itself.

APPLICATIONS

Space Heating Applications

WARNING

- In order to purge air in water pipes within a closed-loop system, an air vent and air separator should be installed in to the system. Required circulation flow rates are labeled next to each application diagram. These flow rate requirements must be followed.
- Toxic chemicals used in boiler treatments such as alcohol, glycerol and glycol groups must not be introduced into the system if the system incorporates an open-loop potable water system.
- Toxic chemicals used in boiler treatments such as alcohol, glycerol and glycol group must not be introduced into the system when used for open loop potable water and space heating.
- The water heater can be used to supply potable water and space heating and shall not be connected to any heating system or component(s) previously used with non-potable water where any chemicals were added to the water heating appliances.
- When the system requires water for space heating at temperatures higher than required for other uses, a means such as a mixing valve shall be installed to temper the water for those other uses in order to reduce scald hazard potential.
- Water temperature over 125 °F (52°C) can cause severe burns instantly or death from scalds.
- Chemicals such as diluted Glycol can be used for radiant floor, Hydro/fan coil air or Baseboard heating only. The diluted solution of glycol must contain between 25 and 55% of Glycol. Be aware that in closed-loop glycol systems, low pressure in the heat exchanger can cause low-temperature boiling, resulting in excessive noise and damage to the water heater. Consult with the glycol maker for specifications prior to use.

Re-circulation:

* The recirculation pump is to be controlled by:

-Dual-set aquastat (recommended w/timer)

OR

-“Pump Control Connections”. Refer to p.22.

* The recirculation pump is to provide no less than 2 GPM and no more than 4 GPM through each activated unit in the system.

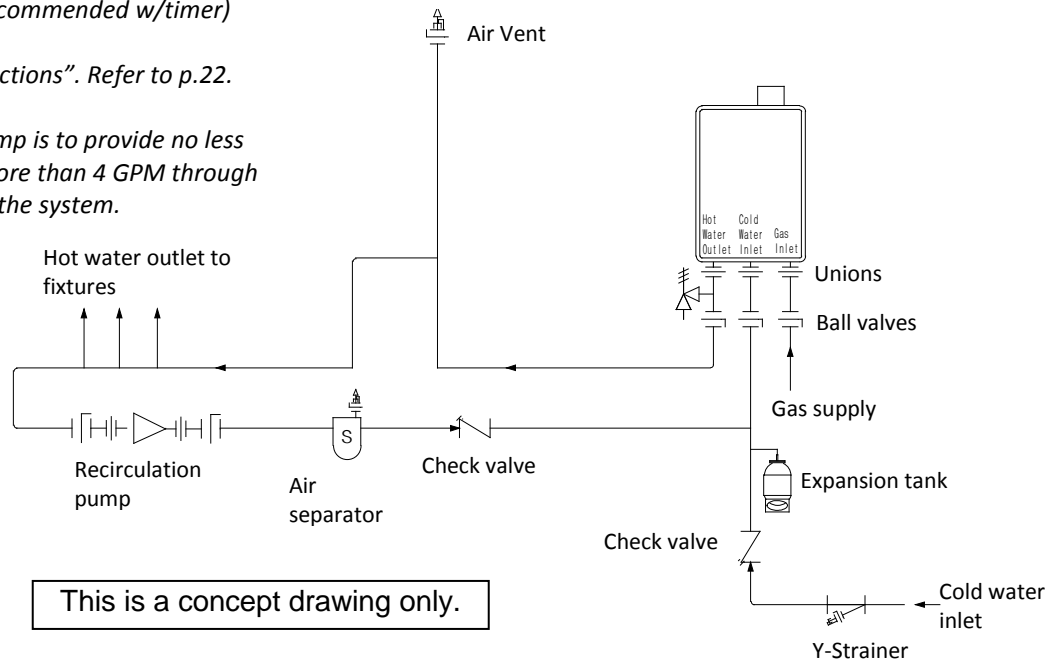

Dual-purpose hot water heating (Domestic and Space Heating):

Diagrammatic Layout of Radiant Heating and Domestic Water Heater Per Mass. Code

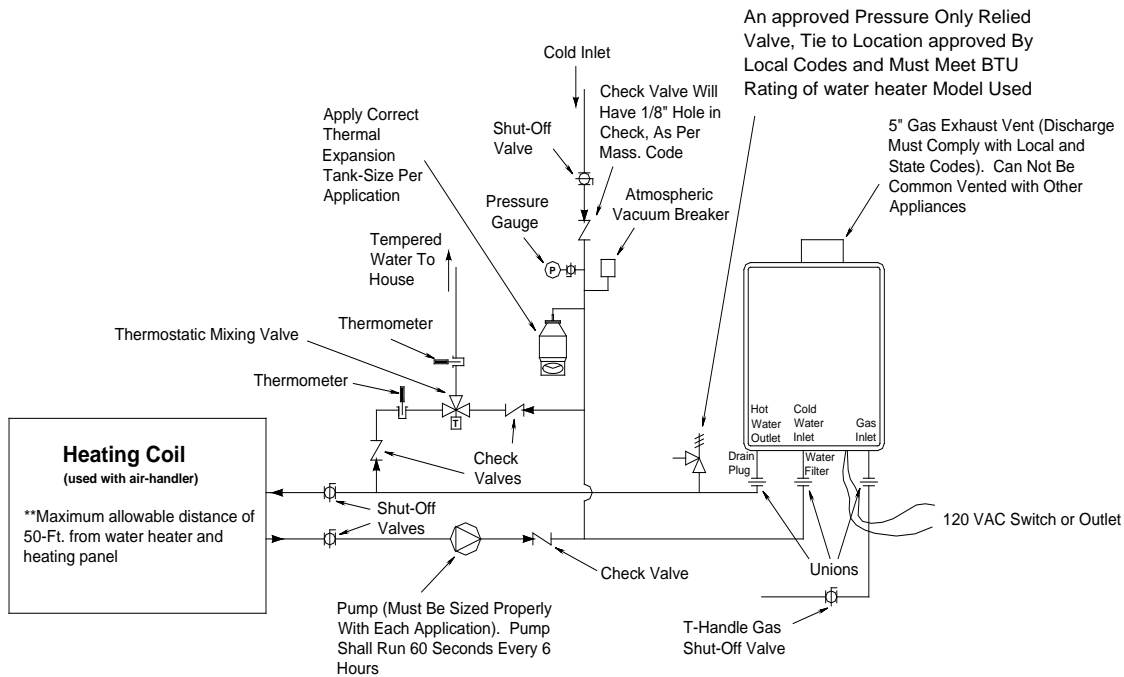

* The circulation pump is to provide no less than 2 GPM and no more than 4 GPM through each activated unit in the system.

Priority Control Devices such as a flow switch, an Aquastat or other electronic controller can be used to prioritize the domestic water system over the heating system.

Warning: Follow all local codes, or in the absence of local codes, follow the most recent edition of the National Standard Code, ANSI Z21. 10.3.

Warning: This illustration is a concept design only. The reference to the 1/8th hole in check is only for the State of Massachusetts. There are a wide variety of variations to the application of controls and equipment presented. Designers must add all necessary safety and auxiliary equipment to conform to code requirements and design practice. For more details, contact the manufacturer.

ADDITIONAL CLEARANCES

Please follow all local and national codes in regards to proper termination clearances. In the absence of such codes, the following clearances can be used as guidelines. Local codes supersede these guidelines.

For sidewall terminations

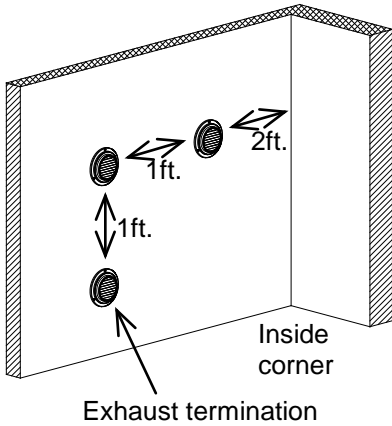

For multiple sidewall exhaust terminations (e.g. multi-unit systems), an exhaust termination must be at least 1 ft. away from another exhaust termination. An exhaust termination must also be at least 2 ft. away from an inside corner (if the adjacent wall is less than 2 ft. of length, the minimum required distance away from the inside corner will be equal to the length of the wall).

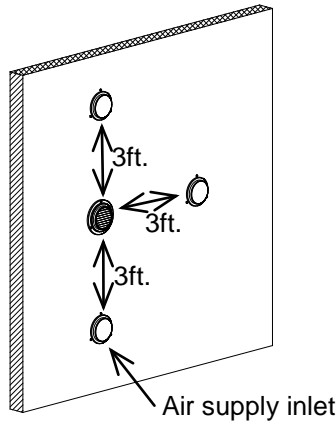

For Direct-Vent sidewall terminations that use two separate penetrations for the intake and exhaust, distance the intake and exhaust terminations at least 3 ft. away from each other, no matter the orientation.

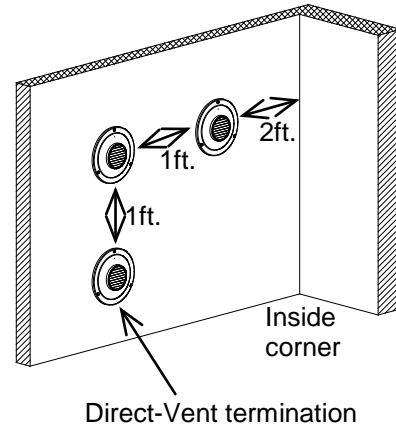

For multiple-unit, direct-vent sidewall terminations that combine the intake and exhaust into a single penetration, space each direct-vent termination at least 1 ft. away from each other, no matter the orientation. A direct-vent termination must also be at least 2 ft. away from an inside corner (if the adjacent wall is less than 2 ft. of length, the minimum required distance away from the inside corner will be equal to the length of the wall).

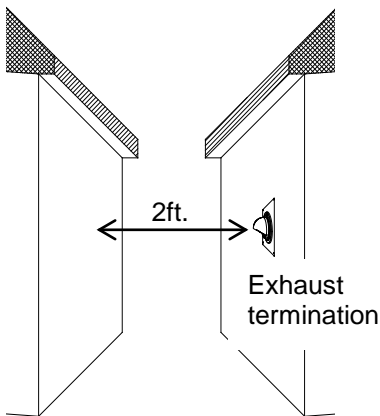

Exhaust and/or Direct-Vent sidewall terminations should be at least 2 ft. away from an opposite surface/wall. Do not place the termination directly in front of an opening into a building.

For rooftop terminations

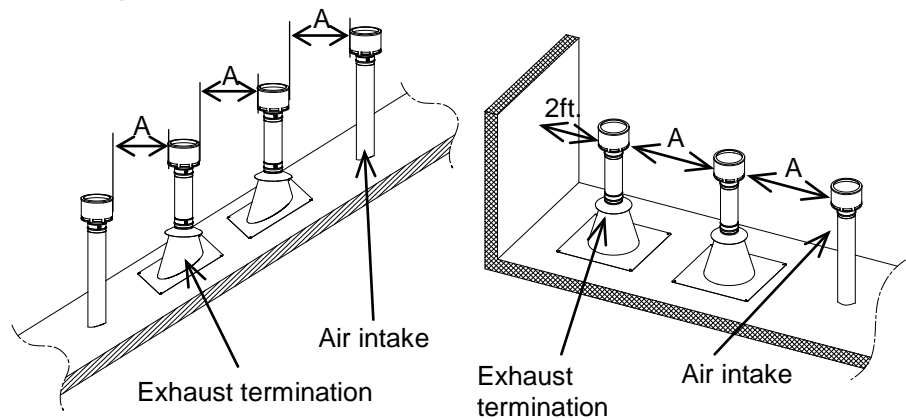

A: in accordance with local codes

For multiple-unit rooftop terminations (whether for standard indoor or Direct-Vent installations) space all exhaust and intake terminations in accordance with local codes. An exhaust termination must be spaced from a wall or surface in accordance with local codes as well. In the absence of such a code, an exhaust termination must be a horizontal distance of at least 2 ft. away from a wall or surface.

OPTIONAL ITEMS

1. Temperature remote controller: 9007603005 (TM-RE30)



The temperature remote controller has two functions. It allows the output temperature from the water heater to be adjusted within the range of 100 °F to 185 °F, and it also works as a diagnostic tool that will give a concise error code

whenever there is a problem with the unit. The temperature options are 100 °F, 105 °F, 110 °F, 115 °F, 120 °F, 125 °F, 130 °F, 135 °F, 140 °F, 145 °F, 150 °F, 155 °F, 160 °F, 165 °F, 170 °F, 175 °F, 180 °F and 185 °F. See the troubleshooting section for information on possible error codes.

2. Multi-unit controller: 9007675005 (TM-MC01) 9008300005 (TM-MC02)



The multi-unit controller can control a maximum of 10 water heaters, from 15,000 BTU to 3,800,000 BTU. It also works as a diagnostic tool that will give a concise error code whenever there is a problem with the unit. The multi-unit controller comes with a remote controller.

3. 5" Backflow preventer and F-F adaptor: 9008202005



There are two functions available for this adaptor which can be connected with the water heater and NovaVent venting line and prevents the backflow of air through the exhaust vent. This helps prevent harmful exhaust gases from entering the home, as well as helping to prevent the unit from freezing in areas where cold air can be blown or drawn into the exhaust

system. Install this adaptor in accordance with the installation instructions that are packaged with the adaptor and any applicable codes.

4. Vent cap: 9007677005 (TM-VC50)



The vent cap is for outdoor installation with the 910 (T-M50) water heater. The cap is installed on the top of the unit, instead of connecting an exhaust vent pipe. The cap will

prevent any debris that might be in the environment from entering the unit and causing damage or a fire hazard, as well as preventing rain or other weather from entering the unit.

5. Direct-vent conversion kit: 9007669005 (TM-DV50)



This kit can be used to convert the 910 (T-M50) from a conventional vent system to a direct-vent (or sealed combustion) system. This is a CSA tested conversion kit. Install this conversion kit in accordance with the manufacturer's installation instructions and any applicable codes.

6. Pipe cover: 9007673005 (TM-PC50)



The pipe cover protects the plumbing pipes to the 910 (T-M50) from unexpected adjustments. This pipe cover is fixed to the bottom of the water heater, which hides the plumbing and improves the visual aspects of the whole installation for the water

heater.

7. Sidewall vent terminator (Hood) and Wall thimble:

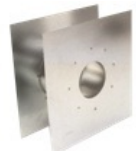

Wall Thimble



Terminator Hood

They are used when venting out through the wall. These terminations are special stainless steel vents for gas applications and are UL listed as Category II, III and IV. For different wall thickness, there are two ranges of lengths available. (Refer to the NovaVent brochure for details.) Install these vent terminations in accordance with their installation instructions and any applicable local codes.

Part #	Covering wall thickness
9008347005	Wall Thimble 4"-7"
9008348005	Wall Thimble 5"-10"
9008197005	Terminator Hood

COMPONENTS DIAGRAM

Case assembly

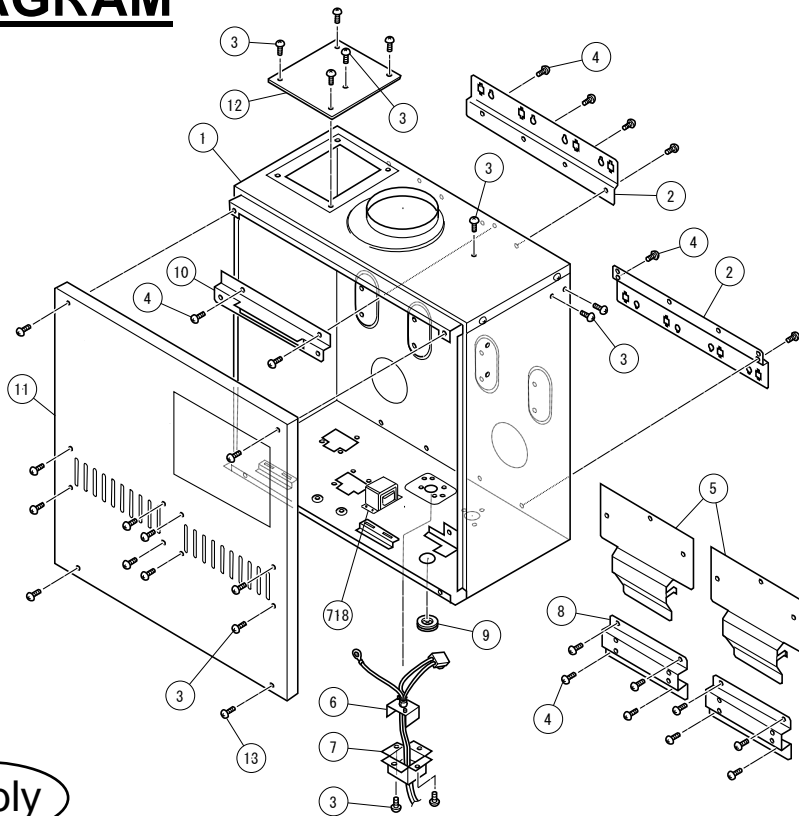

Computer board assembly

The 910 (T-M50) and the 910 ASME (T-M50 ASME) models share the same components.

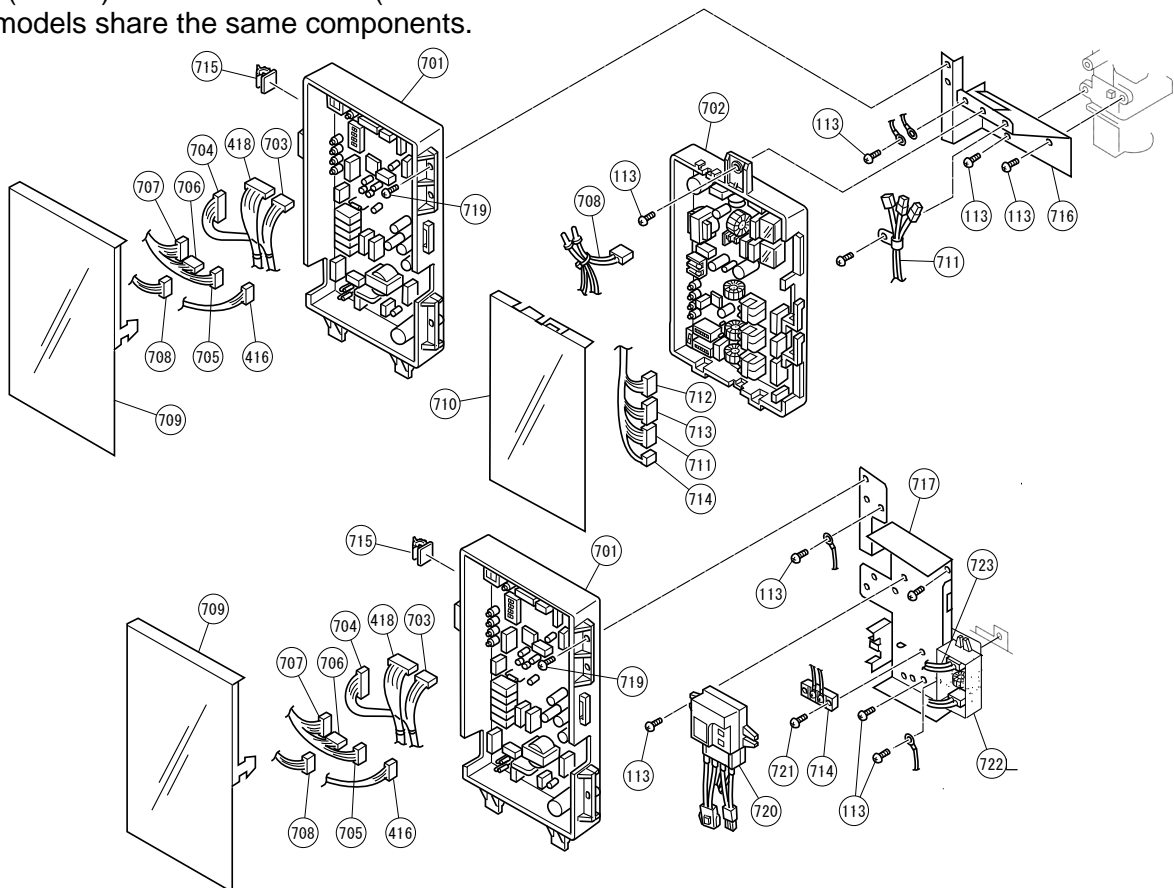

Burner assembly

The 910 (T-M50) and the 910 ASME (T-M50 ASME) models share the same components.

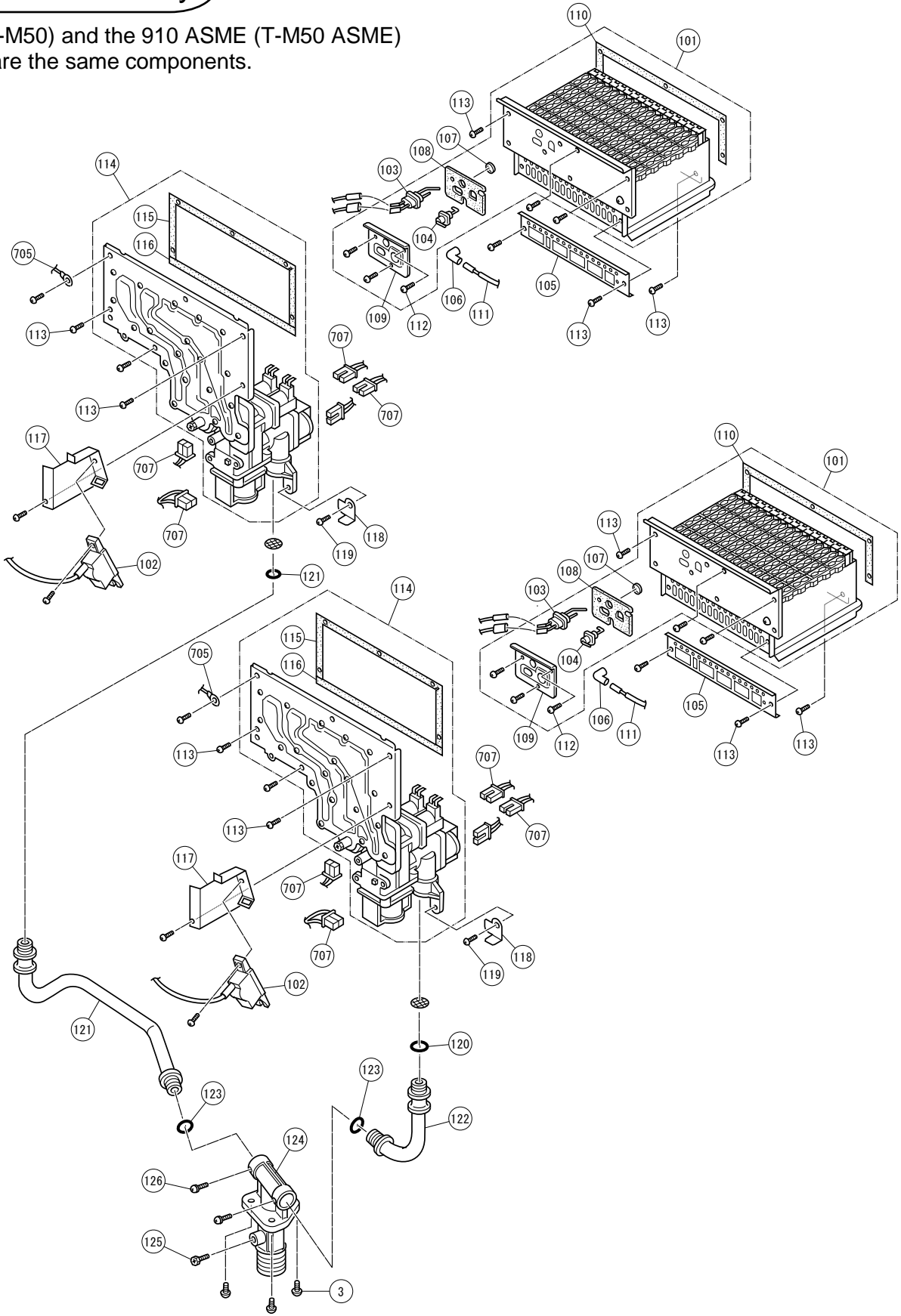

Combustion and Exhaust assembly

Other than Part# 444, Part# 445, Part# 446 and Part# 447, the 910 (T-M50) and the 910 ASME (T-M50 ASME) models share the same components.

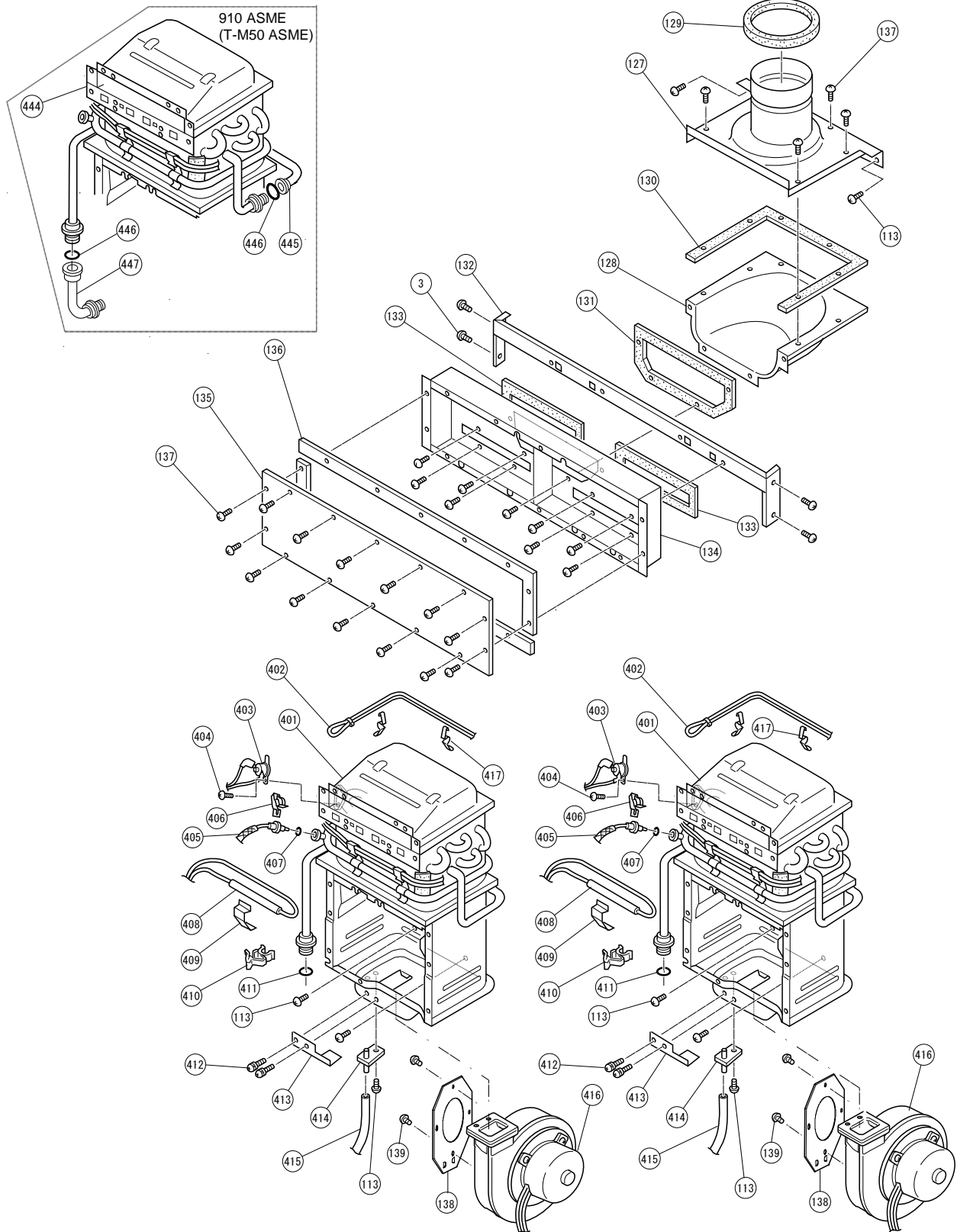

Water way assembly

910 (T-M50)

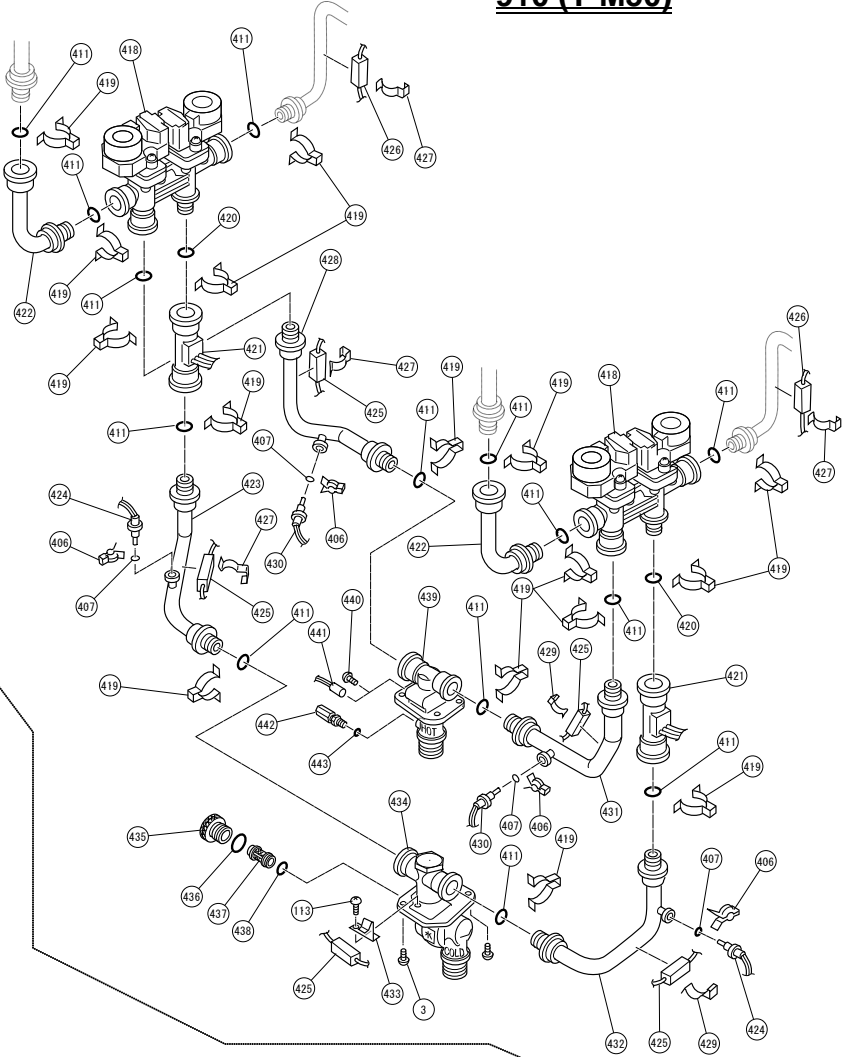

910 ASME (T-M50 ASME)

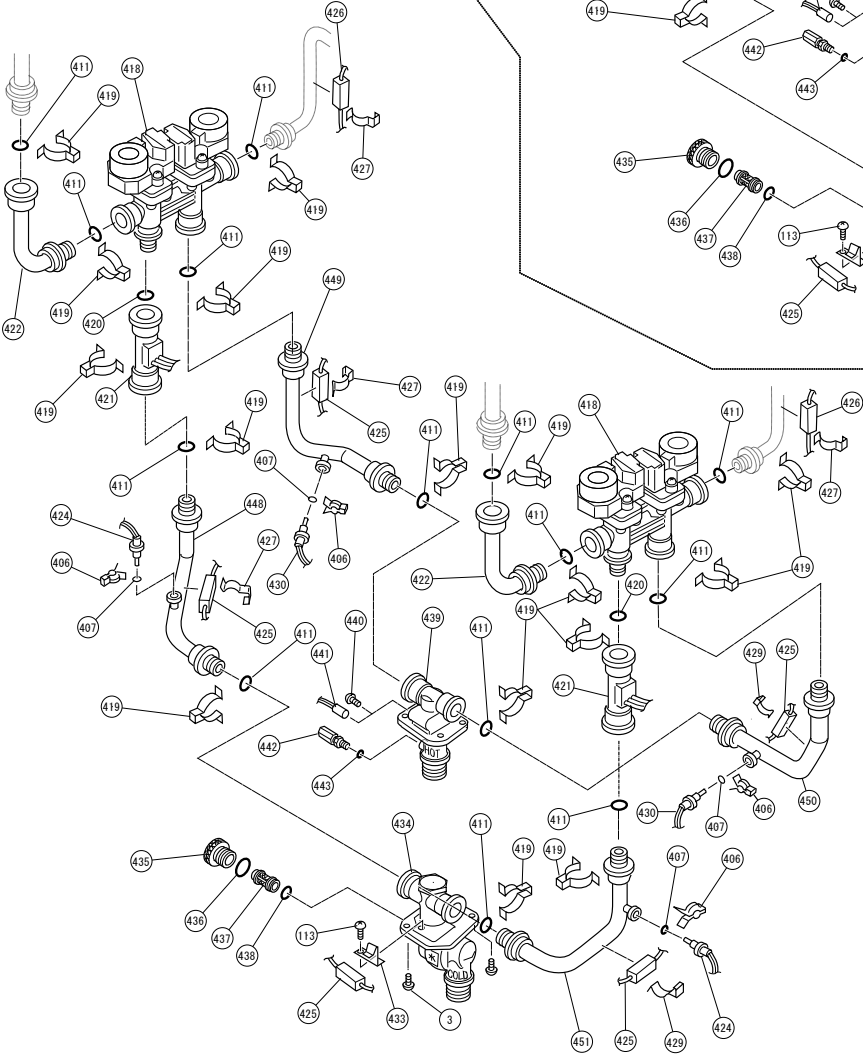

PARTS LIST

Item#	Description	Part#	
		910 models	T-M50 models
001	Case assembly	319143-265	EM305
002	Brackets	319143-012	EM335
003	Screw M4X10 (w/washer)	319143-325	EW001
004	Screw M4X10 (Coated)	319143-026	EW002
005	Back guard panel	319143-237	EM264
006	Power supply code assembly	319143-277	EM333
007	Junction box	319143-014	EKJ64
008	Chamber fixing plate	319143-230	EM255
009	Rubber bush	319143-334	EX00B
010	Exhaust fixing plate	319143-236	EM263
011	Front cover	319143-262	EM301
012	Air blockage plate	319143-246	EM278
013	Screw M4X12 (w/washer)	319143-025	EW000
101	Burner assembly	319143-308	EM445
102	Igniter	319143-052	EKN74
103	Flame rod	319143-035	EKK0E
104	Igniter rod	319143-037	EKK0F
105	Damper	319143-192	EKK1P
106	Rod cap	319143-038	EKN61
107	Burner window	319143-033	EKK2V
108	Rod holder gasket	319143-034	EKK2W
109	Rod holder	319143-036	EKK32
110	Burner holder gasket	319143-032	EKK0G
111	High voltage igniter cable	319143-039	EKK2M
112	Pan screw M4X8	319143-059	EW00D
113	Screw M4X10	319143-060	EW003
114	Manifold assembly with gas valve assembly LP	319143-263	EM302
	Manifold assembly with gas valve assembly NA	319143-264	EM303
115	Manifold gasket A	319143-044	EKK2Y
116	Manifold gasket B	319143-045	EKK2K
117	Igniter plate	319143-051	EKK1B
118	Gas connection plate	319143-337	EX00J
119	Pan screw M4X10	319143-062	EW006
120	O-ring P20 NBR (Black)	319143-057	EK042
121	Gas pipe left	319143-257	EM293
122	Gas pipe right	319143-253	EM289
123	O-ring P18 NBR (Black)	319143-350	EZP18
124	Gas inlet	319143-250	EM284
125	Hex head screw M4x8	319143-063	EW005
126	Pan screw M4X6 (w/washer)	319143-090	EW00L
127	Exhaust connecter	319143-261	EM300
128	Exhaust combining box	319143-276	EM331
129	Silicon ring	319143-206	EKK3G
130	Exhaust gasket A	319143-238	EM266
131	Exhaust gasket B	319143-239	EM267
132	Case beam	319143-249	EM282
133	Exhaust auxiliary plate	319143-275	EM330
134	Duct	319143-260	EM299
135	Duct cover	319143-258	EM294

Item#	Description	Part#	
		910 models	T-M50 models
136	Duct gasket	319143-240	EM268
137	Screw M4X10	319143-060	EW003
138	Fan damper	319143-147	EK270
139	Screw M3X6	319143-330	EW00B
140	Freeze protection thermostat	319143-252	EM286
401	Heat exchanger assembly for 910 (T-M50)	319143-268	EM308
402	Overheat-cut-off-fuse	319143-149	EK333
403	Hi-limit switch	319143-095	EKN34
404	Screw M3X6	319143-087	EW00A
405	Output thermistor	319143-096	EKK2T
406	Fastener "4-11"	319143-097	EKH30
407	O-ring P4 FKM	319143-082	EZM04
408	Pipe heater 122	319143-224	EKN86
409	Heater fixing plate	319143-088	EKK27
411	O-ring P16 FKM	319143-083	EZM16
412	Pan Screw M4X12 (w/washer)	319143-061	EW00H
413	Fan motor fixing plate	319143-229	EM252
414	Pressure port	319143-042	EKK2D
415	Urethane tube	319143-344	EX019
416	Fan motor	319143-043	EKK25
417	Fuse fixing plate 18	319143-066	EKK26
418	Water control valve	319143-086	EKH32
419	Fastener "16AG"	319143-077	EX01H
420	O-ring P16 FKM	319143-083	EZM16
421	Flow sensor	319143-092	EKH33
422	Connecting pipe	319143-251	EM285
423	Left cold pipe for 910 (T-M50)	319143-254	EM290
424	Inlet thermistor	319143-085	EKK38
425	Heater 502	319143-333	EX001
426	Heater 101	319143-068	EX002
427	Heater fixing plate 16	319143-125	EK031
428	Left hot pipe for 910 (T-M50)	319143-273	EM328
429	Heater fixing plate 20	319143-124	EKH38
430	Mixing thermistor	319143-190	EKK1A
431	Right hot pipe for 910 (T-M50)	319143-256	EM292
432	Right cold pipe for 910 (T-M50)	319143-255	EM291
433	Heater plate	319143-076	EX021
434	Water inlet	319143-259	EM295
435	Filter plug	319143-070	EM222
436	O-ring P25 FKM	319143-071	EZM25
437	Water inlet filter	319143-072	EX006
438	O-ring JASO#1021 FKM	319143-073	EZN21
439	Water outlet	319143-269	EM309
440	Screw M4X6	319143-328	EW009
441	Heater 117	319143-223	EKN67
442	Outlet drain plug	319143-199	EKK2E
443	O-ring P6 FKM	319143-080	EZM06
444	Heat exchanger assembly for 910 ASME (T-M50 ASME)	319143-270	EM323
445	Connection pipe for 910 ASME (T-M50 ASME)	319143-271	EM326
446	O-ring P18 FKM	319143-349	EZM18

Item#	Description	Part#	
		910 models	T-M50 models
447	Connecting pipe for 910 ASME (T-M50 ASME)	319143-278	EM370
448	Left cold pipe for 910 ASME (T-M50 ASME)	319143-310	EM456
449	Left hot pipe for 910 ASME (T-M50 ASME)	319143-313	EM459
450	Right hot pipe for 910 ASME (T-M50 ASME)	319143-312	EM458
451	Right cold pipe for 910 ASME (T-M50 ASME)	319143-311	EM457
701	Right and left computer board	319143-266	EM306
702	Central computer board	319143-267	EM307
703	PV-FS wire	319143-232	EM258
704	Thermistor connecting wire	319143-233	EM260
705	Flame rod wire	319143-243	EM271
706	Igniter wire	319143-231	EM257
707	Gas valve wire	319143-248	EM280
708	AC100V wire	319143-245	EM277
709	Right and left computer board cover	319143-183	EKH43
710	Central computer board cover	319143-274	EM329
711	Multi communication wire	319143-247	EM279
712	Left communication wire	319143-234	EM261
713	Right communication wire	319143-235	EM262
714	Remote controller terminal	319143-244	EM273
715	Wire Cramp	319143-048	EM167
716	Left PCB fixing plate	319143-241	EM269
717	Right PCB fixing plate	319143-242	EM270
718	Transformer	319143-127	EM296
719	Screw M4X12	319143-343	EX013
720	Ground fault circuit interrupter	319143-227	EM207
721	Screw M3X12	319143-331	EW01A
722	Surge box	319143-284	EM385
723	Surge connecting wire	319143-215	EKK4U

OUTPUT TEMPERATURE CHART

Chart is based on properly sized gas line

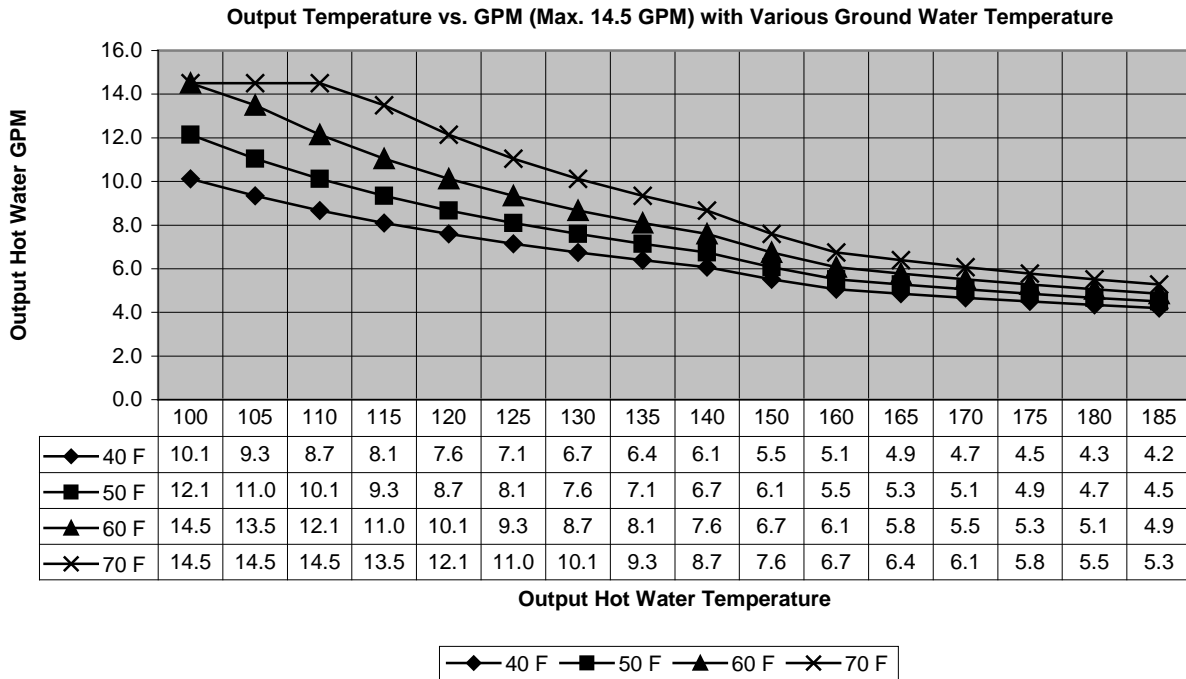

*When the set temperature is 150 °F or higher, maximum flow rate is limited to 10.6 GPM.

LIMITED WARRANTY

- The manufacturer warrants this product against defects in materials or workmanship as described in this document if installed within the United States or Canada. The manufacturer or its authorized Service Representative will, at its sole discretion, repair or replace any failed or defective mechanical or electrical parts, or components thereof, or, if the manufacturer or its authorized Service Representative cannot replace said parts, and repair is not commercially practicable, the manufacturer or its authorized Service Representative will refund the purchase price. The manufacturer or its authorized Service Representative may, at its sole discretion, use new, refurbished or reconditioned parts.
- Warranty for all models:

[Unit: Year]

Application Type	Heat Exchanger	Parts	Labor ⁽¹⁾
Single Family Domestic Hot Water	15 ⁽²⁾⁽³⁾	5	1
Commercial or Multi-Family Domestic Hot Water	10 ⁽²⁾⁽³⁾		
Heating	10 ⁽³⁾⁽⁴⁾		

(1) Limited Labor Coverage

- The manufacturer will provide for reasonable labor charges associated with warranty repairs or replacements within one (1) year from the date of purchase. The manufacturer will only pay directly to the service provider.
- Warranty service must be performed by an authorized Service Representative. A list of authorized Service Representatives is available upon request.
- All warranty claims and warranty service must be authorized and approved by the manufacturer.

(2) Includes recirculation and storage tank applications with proper circulation pump control (e.g. aquastat and/or timer).

- Lack of a proper pump control will reduce the heat exchanger and parts warranty to 3 years

(3) In all applications, the total of length of operation time must be less than 9,000 hours for the 910 (T-M50) and 910 (T-M50) ASME models.

(4) Includes dual-purpose applications (combination heating and domestic).

3. General terms of limited warranty:

This limited warranty gives you specific legal rights, and you may also have other rights which vary from State to State. The manufacturer will honor the warranty to the original retail buyer at the original location only, within the United States or Canada, and it is not transferable.

THIS WARRANTY COVERS ONLY FAILED MECHANICAL AND ELECTRICAL PARTS DUE TO FACTORY DEFECTS UNDER NORMAL USAGE FOR THE PRODUCT'S INTENDED PURPOSES AND WITHIN THE APPLICABLE PERIOD SPECIFIED IN THE TABLE ON P. 51. ONLY DIRECT DAMAGES SHALL BE RECOVERABLE BY A CLAIMANT UNDER THIS LIMITED WARRANTY AND, IN NO EVENT, WHETHER AS A RESULT OF BREACH OF CONTRACT, BREACH OF WARRANTY, TORT LIABILITY (INCLUDING NEGLIGENCE), STRICT LIABILITY, INDEMNITY OR OTHERWISE WILL THE MANUFACTURER BE LIABLE FOR ANY SPECIAL, INCIDENTAL, OR INDIRECT CONSEQUENTIAL DAMAGES INCLUDING PROPERTY DAMAGE, PERSONAL DAMAGES, LOSS OF USE, OR INCONVENIENCE. SOME STATES DO NOT ALLOW THE EXCLUSION OR LIMITATION OF INCIDENTAL OR CONSEQUENTIAL DAMAGES, SO THE ABOVE LIMITATION MAY NOT APPLY TO YOU.

4. Limitation on Duration of Implied Warranties:

ANY IMPLIED WARRANTIES ARISING UNDER STATE LAW, INCLUDING THE IMPLIED WARRANTIES OF FITNESS FOR A PARTICULAR PURPOSE AND MERCHANTABILITY, SHALL IN NO EVENT EXTEND PAST THE EXPIRATION OF ANY WARRANTY PERIOD HEREUNDER. SOME STATES DO NOT ALLOW LIMITATIONS ON HOW LONG AN IMPLIED WARRANTY LASTS, SO THE ABOVE LIMITATION MAY NOT APPLY TO YOU.

5. THIS WARRANTY WILL NOT COVER THE FOLLOWING:

- Any product that is not installed by a licensed plumber, gas installer, or contractor.
- Damages due to accidents, abuse, misuse, improper installation, misapplication, or incorrect sizing.
- Damages due to fires, flooding, freezing, electrical surges, or any Acts of God.
- Damages due to unauthorized alterations, attachments, and/or repairs.
- Damages due to a lack of maintenance (e.g. water filter, water treatment system, vent blockage, etc.).
- Any product installed in an improper environment (e.g. corrosive, dusty, chemically contaminated, excessive lint, etc.).
- Freeze damage that occurs without taking proper preventive measures as described in the installation manual.
- Condensate damage due to improperly installed or lack of a condensate trap (drain).
- Any product not installed in compliance with all applicable local & state codes, ordinances, and good trade practices.
- Any product sold to or installed in areas outside of the fifty states (and the District of Columbia) of the United States of America and Canada.
- Any product installed in applications that cause the water heater to activate more than 300 times per day. (This averages to an activation every 5 minutes in a 24-hour period.)
- Any failures that are not due to defects in materials or workmanship (mechanical and/or electrical parts).
- Damages due to improper installation:
 - Gas: incorrect gas pipe sizing, incorrect gas meter sizing, incorrect gas type, and/or gas pressures that fall outside the product's specified range.
 - Water: incorrect water pipe sizing, water pressures that fall outside the product's specified range, recirculation flow rates that fall outside the product's specified range (air removal), and/or lack of proper methods of air removal in a closed-loop, circulation system. (See installation manual for details.)
 - Electric: supply power voltages that fall outside the product's specified range.
- Damages due to water quality:
 - Introduction of liquids other than potable water or potable water / glycol mixtures into the product.
 - Introduction of pool water, spa water, or any chemically treated water into the product.
 - Introduction of hard water measuring more than 7 grains per gallon (120 ppm) for single family domestic applications or more than 4 grains per gallon (70 ppm) for all other types of applications into the product.
 - Introduction of untreated or poorly treated well water into the product.
 - Introduction of water with pH levels less than 6.5 and greater than 8.5 into the product.