

GENERAL DESCRIPTION:

Concealed, Sensor Operated Selectronic™ Toilet Flush Valve (Rear Access) for wall hung bowls with 1-1/2" back spud.

Inlet includes 1" I.P.S. angle stop (with integral back-flow preventer & wheel handle) and sweat solder kit. Outlet includes 1-1/2" vacuum breaker with adjustable tailpiece, spud coupling and flange.

PRODUCT FEATURES:

- Electronic flush valve with Selectronic™ proximity system for hygienic "Hands Free" operation
- Self-Cleaning Piston helps prevent clogging & reduces maintenance
- Positive Seal ensures leak-free performance without the chance of warping or cracking
- Fully Mechanical Manual Override Button can flush toilet during a power outage
- Range can be adjusted manually or by remote control
- State-of-the Art electronics eliminates false flushes
- Sensor & Electronic controls are hermetically sealed to ensure reliable operation
- Automatic flushes after 24 hours of non-use to maintain trap seal & clean fixture
- Fail-Safe - valve automatically closes on loss of power; remains closed during start-up
- 3 second flush delay
- Low Battery indicator
- All exposed parts are chrome plated
- ADA compliant

MODEL NUMBER:

- 6065.222.007 DC Powered, 1.28 gpf**
 Battery included
REAR ACCESS
 Manual Override
 Chrome plated metal wall plate
- 6067.222.007 Plug-In AC Powered, 1.28 gpf**
SAME AS ABOVE
 AC Supply (M950169-0070A) included
- 6068.222.007 Multi-AC Powered, 1.28 gpf**
SAME AS ABOVE
 10' Extension Cable included
 One AC Supply (sold separately) supplies enough power to run up to 15 flush valves

OPERATING PRESSURE:

Overall Range: 20-125 psi **
 Recommended: 25 psi (flowing) - 80 psi (static)

**Water pressure over 80 psi is not recommended with most plumbing fixtures

BATTERY LIFE:

Up to 4-year life (approx. 200,000 cycles)

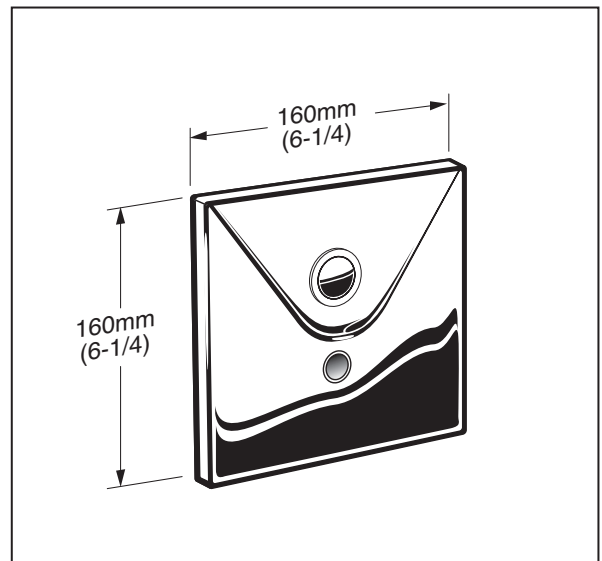

RECOMMENDED SPECIFICATION:

Electronic proximity infrared sensor activated toilet flush valve for wall hung bowls (with 1-1/2" back spud) shall feature self-cleaning piston valve. Valve must automatically remain closed during start-up, close automatically upon loss of power, and include a fully mechanical manual override button to allow for flushing without power. Includes cast brass valve body and chrome-plated metal cover. Angle stop and vacuum breaker included. Must be installed and maintained from the rear. 1.28 gpf / 4.8 Lpf. Flush valve shall be American Standard Model # 606_222.007.

LISTINGS:

- ASSE 1037
- ANSI/ASME A112.19.2
- ADA Compliant

**Roughing-in Dimensions
CONCEALED BACK SPUD BOWLS**

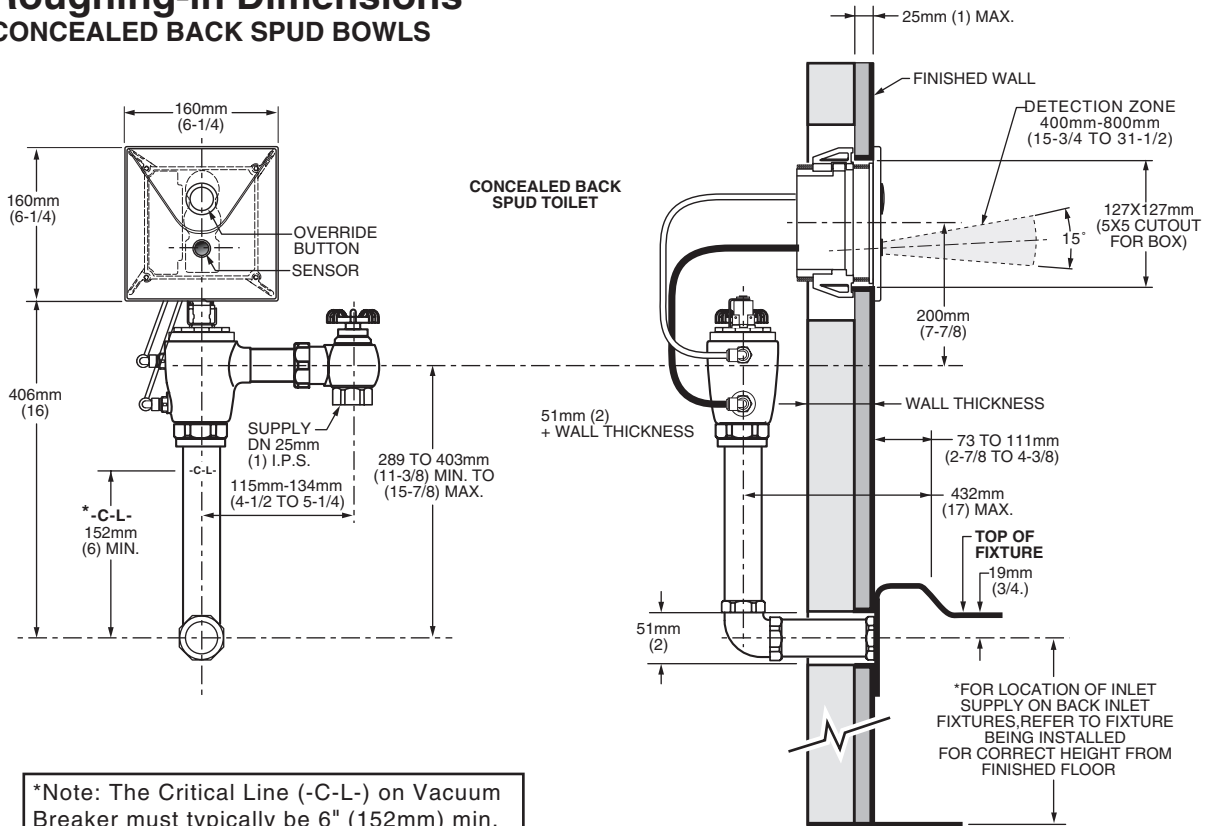

*Note: The Critical Line (-C-L-) on Vacuum Breaker must typically be 6" (152mm) min. above fixture. Consult Codes for details.