

INSTALLATION INSTRUCTIONS

YORKVILLE 1.6 GPF TWO-PIECE

PRESSURE-ASSISTED TOILETS

- Model 2320 Elongated
- Model 2325 Elongated

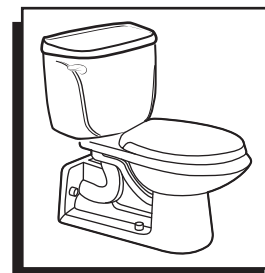

Thank you for selecting American Standard - the benchmark of fine quality for over 100 years. To ensure this product is installed properly, please read these instructions carefully before you begin. (Certain installations may require professional help.) Also be sure your installation conforms to local codes.

⚠ CAUTION: PRODUCT IS FRAGILE. TO AVOID BREAKAGE AND POSSIBLE INJURY HANDLE WITH CARE!

NOTE: For proper operation these products require a minimum of 20 psi line pressure

RECOMMENDED TOOLS AND MATERIALS

- | | | | | | |
|----------------------------------|---------------------|----------------------|---------------------|--------------|---------|
| Putty Knife | Regular Screwdriver | Adjustable Wrench | Carpenters Level | Tape Measure | Hacksaw |
| Neoprene or Graphite Felt Gasket | Closet FLange Set | Flexible Supply Tube | (2) 5/16" Lag Bolts | Sealant | |

1 REMOVE OLD TOILET

- Close toilet supply valve and flush tank completely. Towel or sponge remaining water from tank and bowl.
- Disconnect and remove supply line. NOTE: If replacing valve, first shut off main water supply!
- Remove old mounting hardware, remove toilet and plug wall waste opening to prevent escaping sewer gases.
- Remove closet bolts from flange and clean away old wax, putty, etc. from base area.

NOTE: Mounting surface must be clean and perpendicular to the floor **before** new toilet is installed!

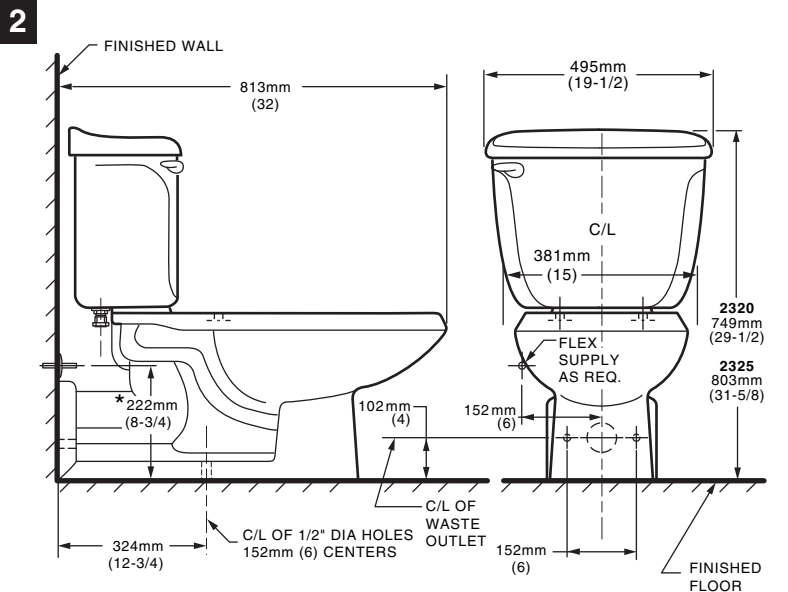

DIMENSIONS (Nominal) NOTE: Distance from floor to closet flange centerline (rough-in) must be 4" (102 mm) with flange surface flush to 1/16" (16mm) max. beyond finished wall.

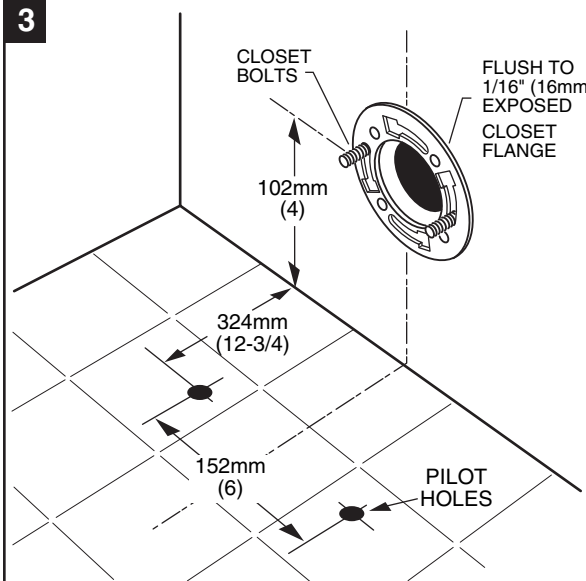

INSTALL CLOSET BOLTS

Install closet bolts in flange channel, turn 90°, and slide into place 6" (152 mm) apart and parallel to floor. (Use putty to hold bolts in place if necessary.) Brace under flooring as needed and drill two mounting pilot holes as shown.

American Standard

Ideal Standard

Incesa Standard

Sadona Standard

Cedelca

Saniwares

U
S
E
F
U
T
U
R
E
S
A
V
E
F
O
R

4

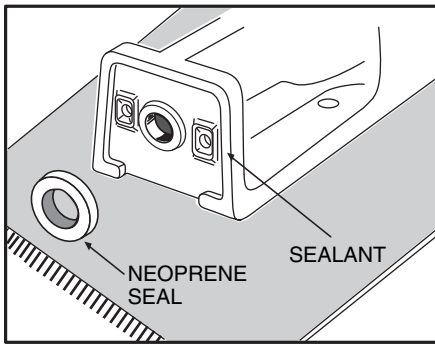

INSTALL NEOPRENE OR GRAPHITE FELT SEAL*

Install seal evenly around waste flange (horn). Apply a thin bead of sealant around base flange.

* Note: Wax seal not recommended for this application.

5

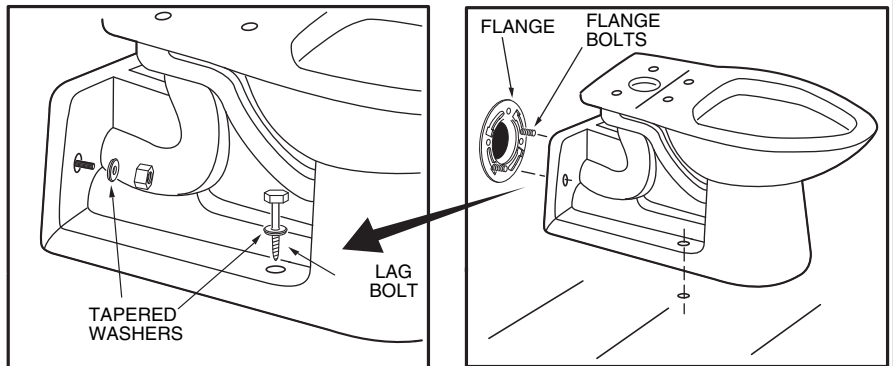

INSTALL TOILET ON FLANGE

- Unplug wall waste opening and slide toilet towards closet flange so bolts project through mounting holes.
- Loosely install retainer tapered washers and nuts. Side of washers marked "THIS SIDE UP" *must* face you!

6

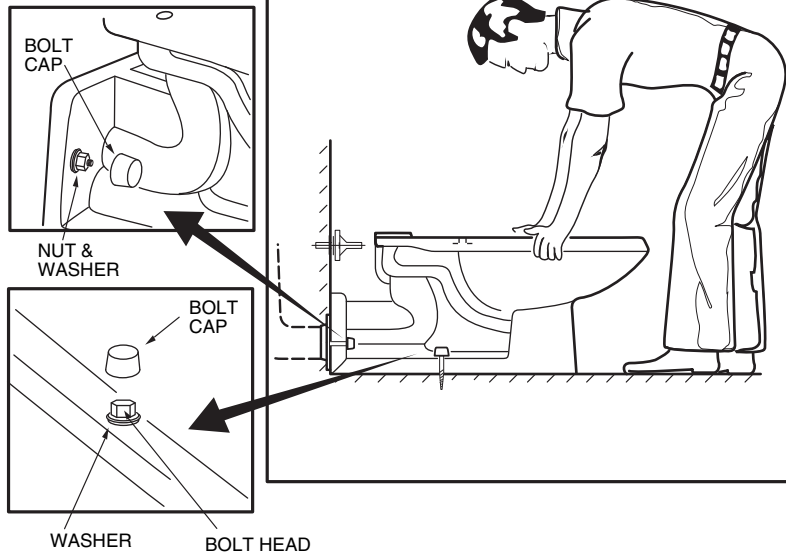

INSTALL TOILET

- Position toilet squarely to wall and, with a rocking motion, push bowl against ring and flange. Alternately tighten nuts until toilet is firmly anchored.
 - ⚠ **CAUTION: DO NOT OVERTIGHTEN NUTS OR BASE MAY BE DAMAGED!**
- Insert the tapered washers (supplied in the kit) into the lag bolts (not supplied). Insert bolts through mounting holes and tighten into pre-drilled floor openings.
- Install the four bolt caps on tapered washers. (If necessary, cut wall bolt length to size before installing caps.)
- Smooth off the bead of sealant around base. Remove excess sealant.

7

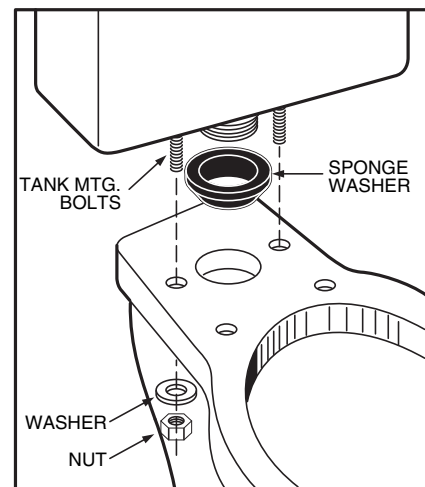

INSTALL TANK

- Install large rubber gasket over threaded outlet on bottom of tank and lower tank onto bowl so that tapered end of gasket fits evenly into bowl water inlet opening, and tank mounting bolts go through mounting holes. Secure with metal washers and nuts.
- With tank parallel to wall, alternately tighten nuts until tank is snugged down evenly against bowl's sanitary ribs.

⚠ **CAUTION: DO NOT OVERTIGHTEN NUTS MORE THAN REQUIRED FOR A SNUG FIT!**

8 **INSTALL TOILET SEAT** Install toilet seat in accordance with manufacturer's directions.

9

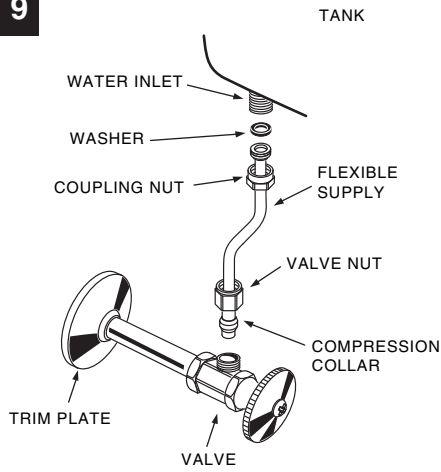

CONNECT WATER SUPPLY

- Connect water supply line between shutoff valve and tank water inlet fitting. Tighten coupling nuts securely.
- Turn on supply valve and allow flushometer tank to fill.
- Check for leakage at fittings, tighten or correct as needed.

10

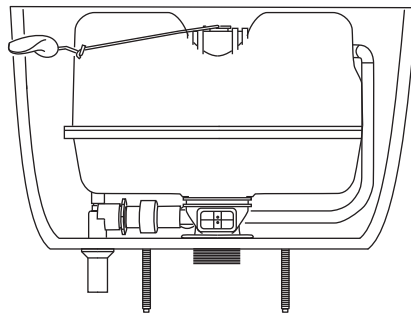

ADJUSTMENTS

The flushometer tank is designed and factory-adjusted to provide a consistent, safe seal depth in the bowl after each flush. Field refill adjustment is not required. The refill has been preset and locked.

FLUSH ACTUATOR ADJUSTMENT - The spacing between the bellcrank and flush actuator may be adjusted to assure positive operation of the trip lever. Proceed as follows:

- Remove tank cover and check that there is approximately 1/32" (0.8mm) gap between the top of the actuator and bottom of the spring rod when it is lifted to remove slack from linkage.
- If necessary, loosen set screw in actuator cap and turn cap to increase gap (clockwise) or decrease gap (counterclockwise), as needed.
- Tighten setscrew securely after adjustment is completed. Replace tank cover.

11

REPAIR PARTS LIST

NOTE: "XXX" and "YYY" represent color or trim finish options. Specify when ordering.

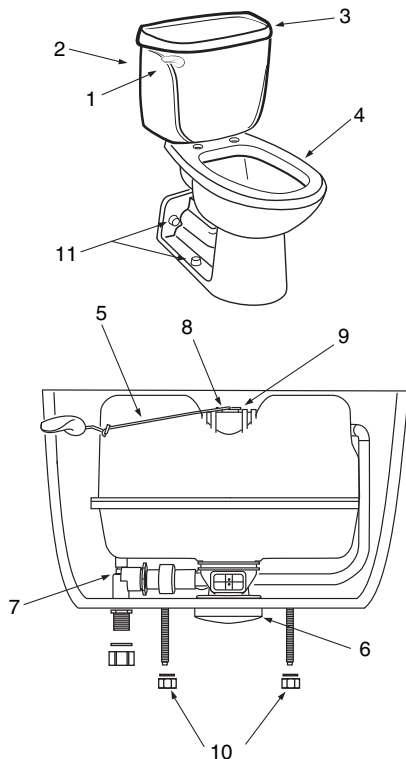

ITEM	PART NO.	DESCRIPTION	QTY
1	738473-YYY0A	TRIP LEVER-LH	1
	738494-YYY0A	TRIP LEVER-RH	
2	4099.100.XXX	TANK (COMPLETE WITH COUPLING COMPONENTS AND L.H. TANK TRIM)	1
	4099.800.XXX	TANK (COMPLETE WITH COUPLING COMPONENTS AND R.H. TANK TRIM)	
3	735084-400.XXX	TANK COVER	1
4	3120.019.XXX	BOWL - ELONGATED	1
	3125.016.XXX	BOWL - ELONGATED 16-1/8" (410mm)	1
5	738493-0070A	SPRING ROD ASSEMBLY-LH	1
	738495-0070A	SPRING ROD ASSEMBLY-RH	
6	034602-0070A	COUPLING GASKET	1
7	738496-0070A	LOWER SUPPLY ASSEMBLY (35 PSI)	1
8	047562-0070A	UPPER SUPPLY ASSEMBLY	1
9	047563-0070A	VALVE CARTRIDGE ASSEMBLY	1
10	730292-0070A	TANK COUPLING KIT	1
11	034783-XXX0A	BOLTS AND CAPS	2
	735083-600.XXX	TANK COVER FOR LOCKING DEVICE	1
	603111-0030A	COVER LOCKING DEVICE KIT	1

12 CARE AND CLEANING

When cleaning your toilet, wash it with mild, soapy water, rinse thoroughly with clear water and dry with a soft cloth. Avoid detergents, disinfectants, or cleaning products in aerosol cans. NEVER use abrasive scouring powders or abrasive pads on your toilet seat. Some bathroom chemicals and cosmetics may damage the seat's finish.

TROUBLESHOOTING GUIDE

NOTE: The presence of a small amount of water in the bottom of the tank is normal. The air inducer is designed to leak for short periods during each flush cycle as a self-cleaning action. Drippage is drained into the bowl. If used on water system containing excessive sand and/or debris, a periodic cleanup of inlet strainer is recommended. (See enclosed instructions for strainer cleaning.)

WARNING

When servicing or replacing components of the flushometer tank system, be sure that the water supply is shut off and the toilet is flushed to relieve pressure in the flushometer tank.
For service of the Flushometer Tank System, see enclosed literature.

PROBLEM	POSSIBLE CAUSE	CORRECTIVE ACTION
Does not flush	<ul style="list-style-type: none"> a. Water supply valve closed. b. Flush actuator incorrectly set. c. Supply line blocked. d. Trip lever linkage damaged. 	<ul style="list-style-type: none"> a. Open valve and allow water to fill tank. b. Follow instruction to adjust flush actuator. c. Shut off water supply, disconnect supply line, and inspect all gaskets and washers. Reassemble. d. Check trip lever, linkage, and actuator wire assemblies for damage.
Poor or sluggish flush	<ul style="list-style-type: none"> a. Supply valve partly closed. b. Plugged inlet strainer. c. Supply pressure too low. d. Partially clogged trapway and/or drain pipe and/or vent. e. Malfunctioning pressure regulator. 	<ul style="list-style-type: none"> a. Open supply valve fully. Be sure that proper supply tube size is used. b. Remove and clean strainer per enclosed instructions c. Normal supply pressure must be at least 20 psi. d. Remove obstruction. Consult a plumber if necessary. e. Replace lower supply assembly.
Toilet leaks	<ul style="list-style-type: none"> a. Poor supply line connection. b. Poor bowl to tank/floor connection. 	<ul style="list-style-type: none"> a. Review Step 9 of installation procedure. b. Review Step 4 through 7 of installation procedure.
Toilet does not shut off	<ul style="list-style-type: none"> a. Supply pressure too low. b. Flush actuator incorrectly set. 	<ul style="list-style-type: none"> a. Normal supply pressure must be at least 20 psi. b. Follow instructions to adjust flush actuator.

AMERICAN-STANDARD ONE-YEAR LIMITED WARRANTY

If inspection of this American-Standard plumbing product, within one year after its initial installation, confirms that it is defective in materials or workmanship, American-Standard will repair or, at its option, exchange the product for a similar model.

This warranty **does not apply** to local building code compliance. Since local building codes vary considerably, the purchaser of this product should check with a local building or plumbing contractor to insure local code compliance before installation.

This warranty **shall be void** if the product has been moved from its initial place of installation; if it has been subjected to faulty maintenance, abuse, misuse, accident or other damage; if it was not installed in accordance with American-Standard's instructions; or if it has been modified in a manner inconsistent with the product as shipped by American-Standard.

American-Standard's option to repair or exchange the product under this warranty does not cover any labor or other costs of removal or installation, **nor shall American-Standard be responsible for any other incidental or consequential damages attributable to a product defect or to the repair or exchange of a defective product, all of which are expressly excluded from this warranty.** (Some states or provinces do not allow the exclusion or limitation of implied warranties, so this exclusion may not apply to you.)

This warranty gives you specific legal rights. You may have other statutory rights that vary from state to state or from province to province, in which case this warranty does not affect such statutory rights.

For service under this warranty, it is suggested that a claim be made through the contractor or dealer from or through whom the product was purchased, or that a service request (including a description of the product model and of the defect) be sent to the following address:

In the United States:

American Standard Inc.,
P.O. Box 6820

Piscataway, New Jersey 08855
Attention: Director of Consumer Affairs

For residents of the United States, warranty information may also be obtained by calling the following toll free number: (800) 442-1902
www.AmericanStandard-US.com

In Canada:

American-Standard,
2480 Stanfield Road
Mississauga, Ontario
Canada L4Y 1S2

Toll Free: (800) 387-0369
Toronto Area: (905) 949-4800

In Mexico:

Customer Service Manager
Ideal Standard, S.A. de C.V.
Via Morelos #330
Col. Santa Clara
Ecatepec 55540 Edo. Mexico