

**GENERAL DESCRIPTION:**

Diaphragm-Type Flush Valve for floor-mounted or wall-hung 1-1/2" clinic sinks.

**PRODUCT FEATURES:**

- Hands-free infrared sensor-operated gear actuator with chrome plated metal housing
- Patent-pending DynaClean™ wiper spring technology significantly reduces maintenance and downtime
- Self-cleaning wiper spring cleans the refill orifice with every flush; prevents valve run-on from clogging
- Prevents costly excess water usage and potential flooding
- Premium, chlorine resistant EvoLast™ diaphragm material prevents premature deterioration and failure
- Dezincification-resistant brass alloy
- Electronic courtesy flush button
- Optional Sanitary Flush: Automatic flush after 24 hours of non-use
- Low Battery Indicator: Yellow LED flashes when batteries need to be replaced
- Easy Battery Replacement: Water does not need to be shut off to change batteries
- High back pressure vacuum breaker prevents dripping
- Adjustable tailpiece for rough-in flexibility
- Can be installed left or right handed
- No external volume adjustment
- ADA complaint

**MODEL NUMBER:**

❑ **6147SM117.002** Flush Valve for 1-1/2" top spud clinic sink, 24" Supply C\L to top of bowl, 6.5 gpf/24.6 Lpf

**OPERATING PRESSURE:**

25 psi (flowing)-80 psi (static)

**FLOW REQUIREMENT:**

25gpm (94.6 L/min.)

**BATTERY LIFE:**

100,000 flushes (3+ years @ 3,000 flushes per month)  
(4) "C" alkaline batteries included

**ADJUSTABLE RANGE:**

8" to 48" (32" default)

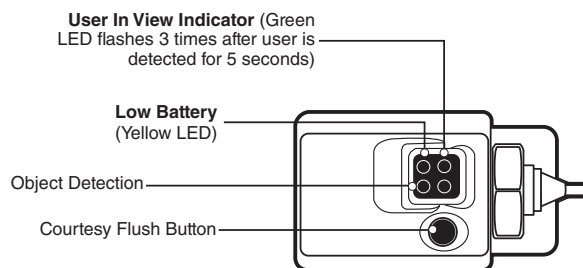

**RECOMMENDED SPECIFICATION:**

Clinic sink flush valve includes sensor-operated gear actuator with metal casing. Shall feature self-cleaning diaphragm valve with integral DynaClean wiper spring in bypass orifice to prevent clogging. Advanced EvoLast diaphragm provides superior chlorine-resistance. Includes dezincification-resistant cast brass valve body with chrome finish. Includes sweat solder kit with wall flange and cover tube. Angle stop with back-flow protection and vandal-resistant stop cap. High back pressure vacuum breaker included. 6.5 gpf / 24.6 Lpf Flush valve shall be American Standard Model # 6147SM.117.002

**LISTINGS:**

- ASSE 1037
- ANSI/ASME A112.19.2
- ADA Compliant

**INCLUDES:**

- 1" I.P.S. angle stop with back-flow prevention and vandal-resistant cap
- Sweat solder kit including cover tube and wall flange
- High back pressure vacuum breaker with down tube
- Spud coupling & flange for 1-1/2" top spud

**Roughing-in Dimensions**

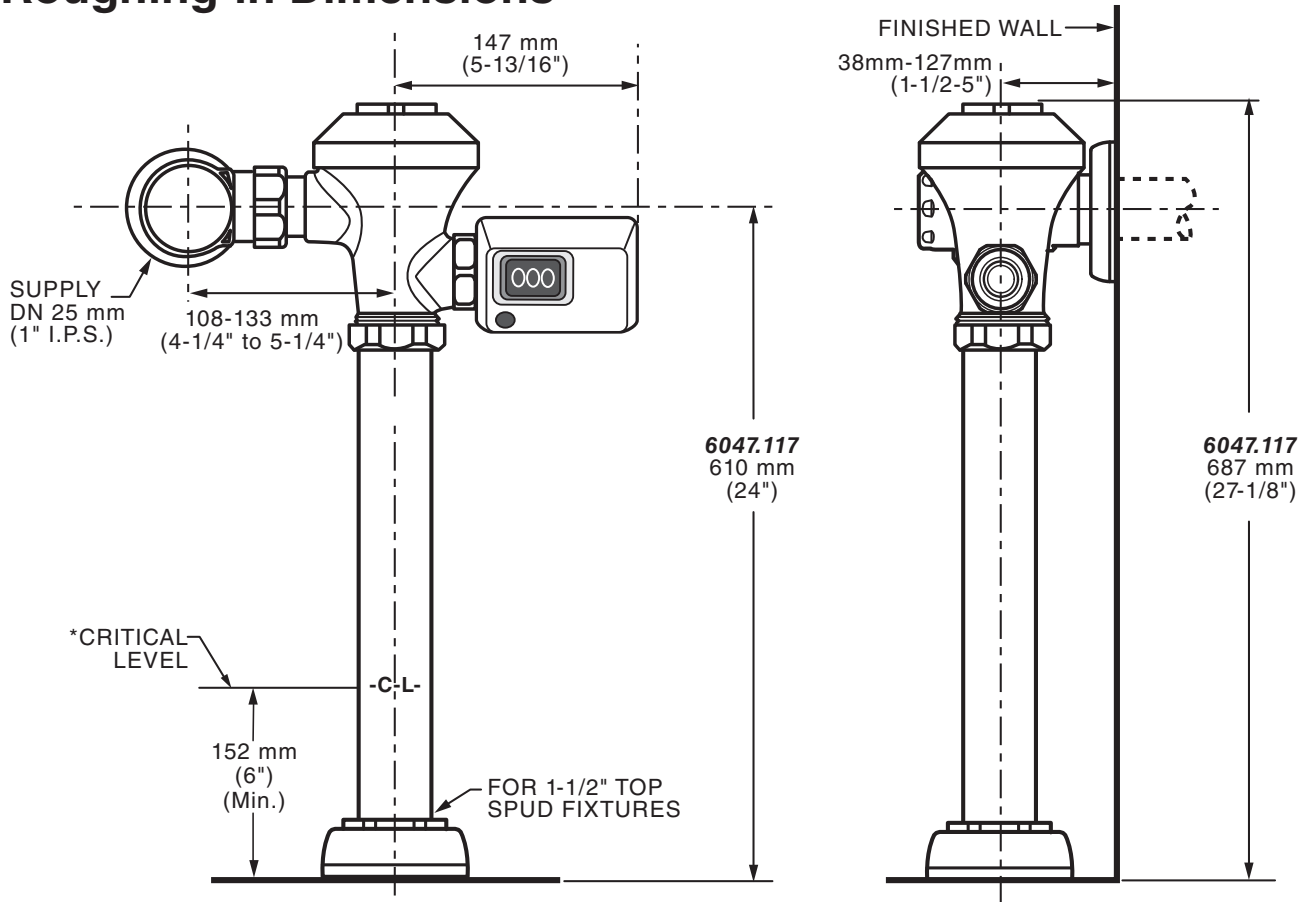

\*Note: The Critical Line (-C-L-) on Vacuum Breaker must typically be a minimum of 6" (152 mm) above fixture. Consult Codes for details.

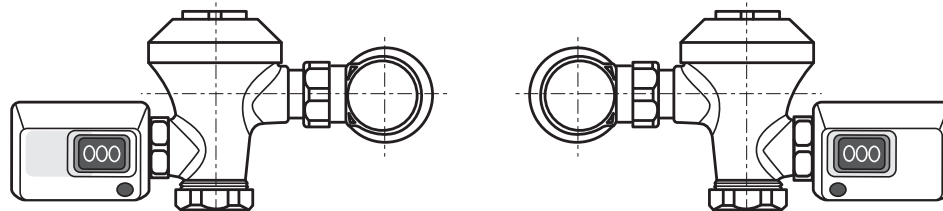

**Left or Right Hand Installation**