

INSTALLATION INSTRUCTIONS



DECORUM URINAL

Models: 6042, 6043

Thank you for selecting American Standard – the benchmark of fine quality for over 100 years. To ensure this product is installed properly, please read these instructions carefully before you begin. (Certain installations may require professional help.) Also be sure your installation conforms to local codes.

BEFORE YOU BEGIN

▲ CAUTION: PRODUCT IS FRAGILE. TO AVOID BREAKAGE AND POSSIBLE INJURY HANDLE WITH CARE!

NOTES:

- Pictures may not exactly define contour of china and components.
- Observe all local plumbing and building codes.
- Refer to local codes and manufacturer's instructions for flush valve requirements.
- Carefully inspect the new urinal for damage.
- Fixture dimensions are nominal and conform to tolerances by ASME Standard A112.19.2.
- Site preparation may require additional tools and hardware.

RECOMMENDED TOOLS AND MATERIALS

Safety Glasses Tape Measure Adjustable Wrench Blade Screwdriver Pencil Levels
 Thread Sealant 1/4" Ratchet Hole Cutting Equipment

SAVE FOR FUTURE USE

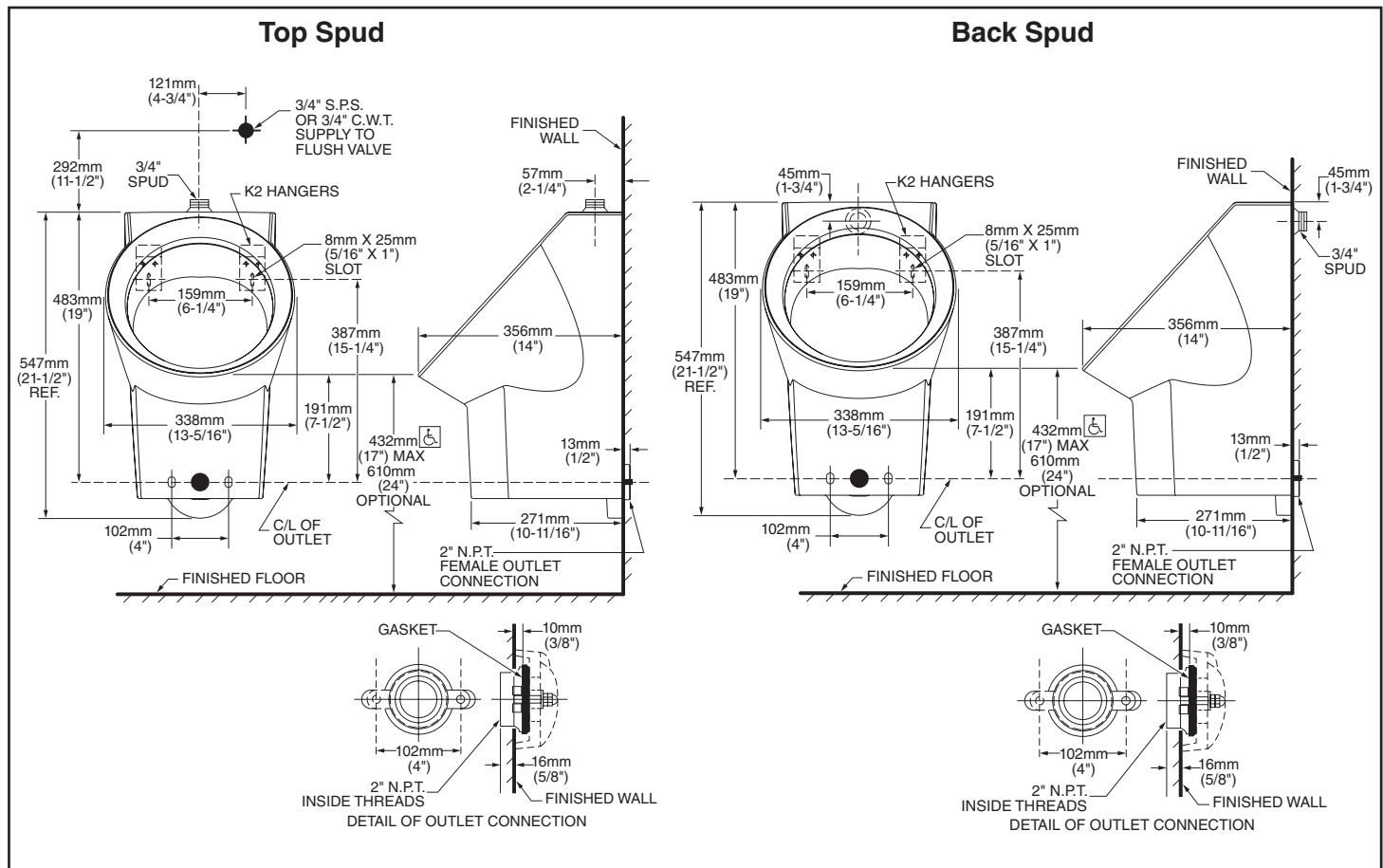

Product names listed herein are trademarks of AS America Inc.
 © AS America Inc. 2015

7301792-100 Rev. B

7301792-100B

1 PREPARATION

- Turn the water supply OFF.
- Install or relocate the supply tubing and waste pipe as necessary to conform to the roughing in dimensions.
- Install the shut off valve.
- Install adequate support framing for the wall hangers as needed.
- Determine the position of the waste pipe nipple. When establishing the nipple length, take into account the length of the urinal outlet spud and the distance the female collar will thread onto the waste pipe nipple.

NOTE: Add a little extra length to the nipple to allow for gasket space.

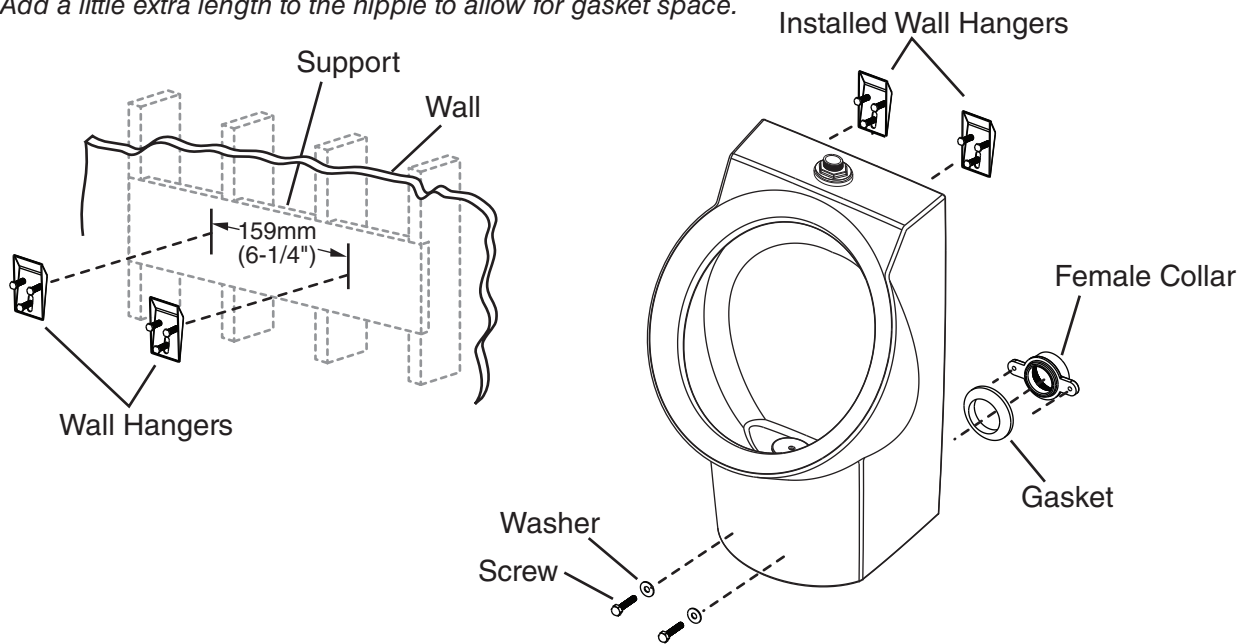

2 INSTALL THE URINAL

▲ CAUTION: RISK OF PERSONAL INJURY OR PRODUCT DAMAGE. HANDLE WITH CARE. VITREOUS CHINA CAN BREAK OR CHIP IF THE PRODUCT IS HANDLED CARELESSLY.

▲ CAUTION: RISK OF PRODUCT DAMAGE. DO NOT OVERTIGHTEN THE BOLTS.

- Install the wall hangers according to the roughing in illustration.
- Apply thread sealant tape to the pipe threads and install the female collar to the waste pipe.
- Place the gasket onto the female collar with the beveled surface facing away from the collar.
- Carefully position the urinal on the wall hangers.
- Secure the urinal to the female collar using the screws and washers provided.

3 COMPLETE THE INSTALLATION

- Install the flush valve according to the manufacturer's instructions.
- Connect the water supply and complete the waste pipe connections.
- Turn on the water supply.
- Flush and check the entire installation for leaks.

CARE & CLEANING

Wash with mild soapy water and rinse thoroughly. Dry with a soft cloth. Avoid detergents, disinfectants or cleaning products in aerosol cans as they may damage fittings.

In the United States:

American Standard Brands
P.O. Box 6820
Piscataway, New Jersey 08855
Attention: Director of Customer Care
For residents of the United States, warranty information may also be obtained by calling the following toll free number: (800) 442-1902
www.americanstandard.com

In Canada:

AS Canada, ULC
5900 Avebury Rd.
Mississauga, Ontario
Canada L5R 3M3
Toll Free: (800) 387-0369
www.americanstandard.ca

In Mexico:

American Standard B&K Mexico
S. de R.L. de C.V.
Via Morelos #330
Col. Santa Clara
Ecatepec 55540 Edo. Mexico
Toll Free: 01-800-839-1200
www.americanstandard.com.mx

INSTRUCCIONES DE INSTALACIÓN

American Standard

MINGITORIO DECORUM

Modelos: 6042, 6043

Gracias por elegir American Standard - el parámetro de primera calidad por más de 100 años. Para asegurarse de que el producto esté instalado correctamente, por favor lea estas instrucciones cuidadosamente antes de comenzar. (Ciertas instalaciones pueden requerir ayuda profesional.) Asegúrese de que su instalación cumpla con los códigos locales.

ANTES DE COMENZAR

⚠ PRECAUCIÓN: EL PRODUCTO ES FRÁGIL. ¡MANIPÚLELO CON CUIDADO PARA NO ROMPERLO Y EVITAR POSIBLES LESIONES!

NOTAS:

- Es posible que las imágenes no definan con exactitud el contorno de la cerámica y los componentes.
- Cumpla todas las normas locales de plomería y construcción.
- Consulte los códigos locales y las instrucciones del fabricante para conocer los requisitos de la válvula de descarga.
- Inspeccione con cuidado el nuevo mingitorio para ver si tiene daños.
- Las dimensiones del accesorio son nominales y cumplen con las tolerancias establecidas por la norma ASME A112.19.2.
- La preparación del sitio puede requerir herramientas y accesorios adicionales.

HERRAMIENTAS Y MATERIALES RECOMENDADOS

Lentes de seguridad	Cinta métrica	Llave ajustable	Destornillador plano	Lápiz	Niveles
Sellador para roscas	Trinquete de 1/4"	Equipo para cortar orificios			

Acople superior

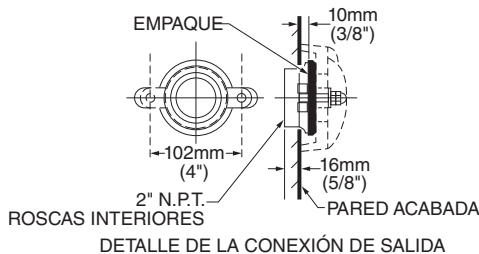
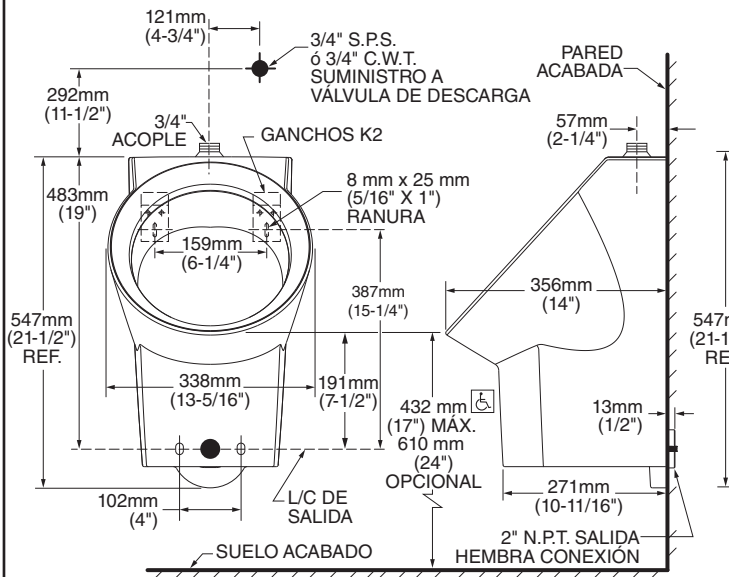

Acople posterior

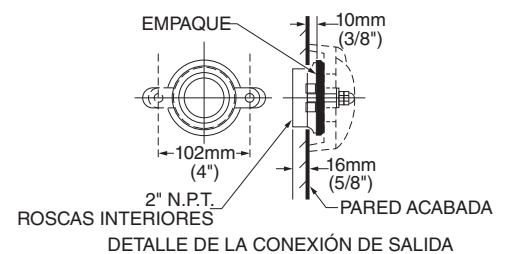
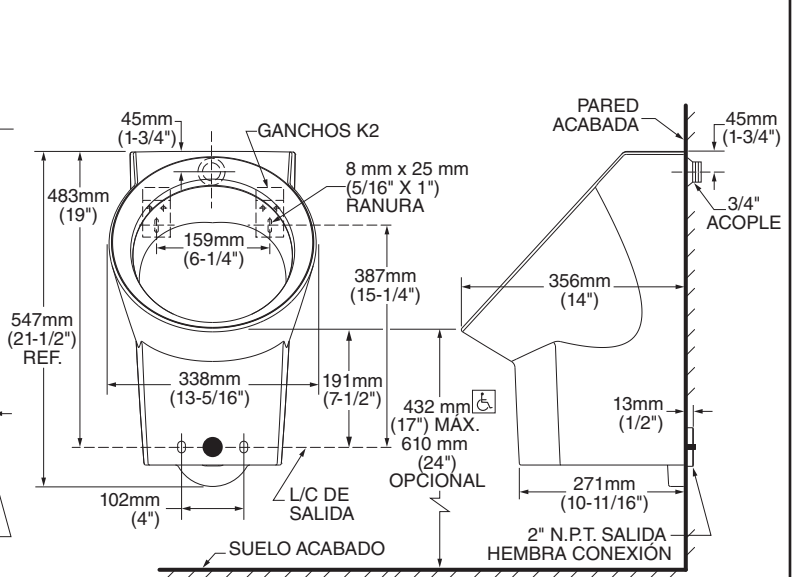

1 PREPARACIÓN

- Cierre el suministro de agua.
- Instale o reubique la tubería de suministro y el tubo de desagüe conforme sea necesario para cumplir con las dimensiones calculadas.
- Instale la válvula de cierre.
- Instale el marco de soporte adecuado para los ganchos de pared según sea necesario.
- Determine la posición de la boquilla del tubo de desagüe. Cuando establezca la longitud de la boquilla, tome en cuenta la longitud del acople de la salida del mingitorio y la distancia en que se enrosca el aro hembra sobre la boquilla del tubo de desagüe.

NOTA: Agregue un poco más de longitud en la boquilla para permitir que el empaque tenga espacio.

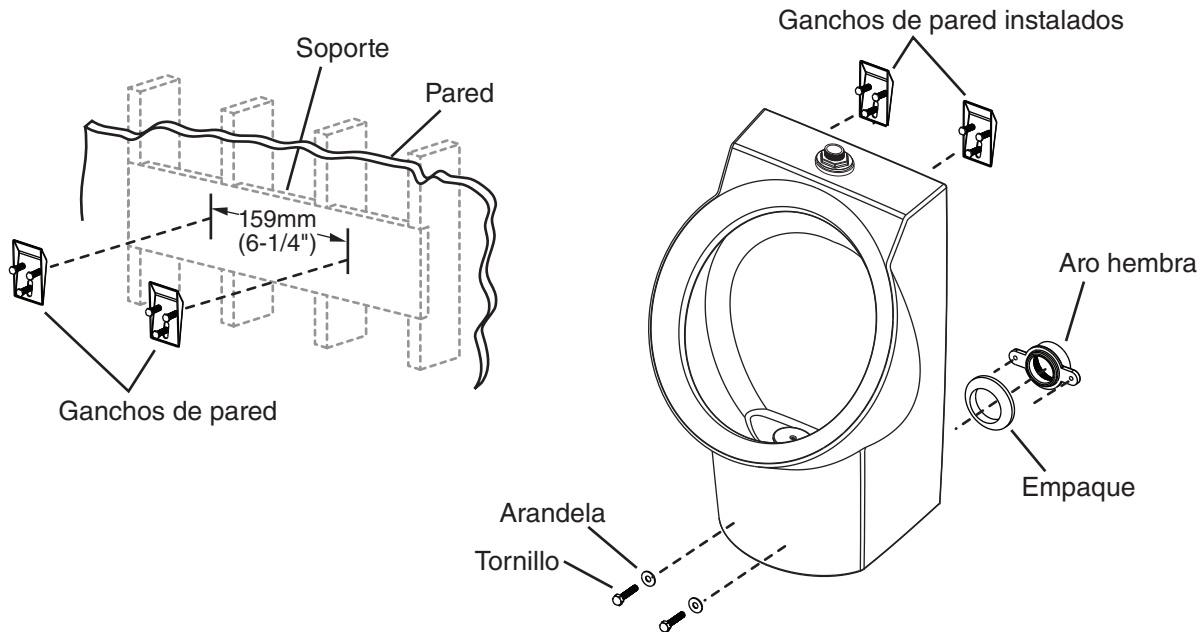

2 INSTALE EL MINGITORIO

⚠ PRECAUCIÓN: RIESGO DE LESIÓN PERSONAL O DAÑO DEL PRODUCTO. MANEJE CON CUIDADO. LA PORCELANA VÍTREA SE PUEDE ROMPER O DESPOSTILLAR SI EL PRODUCTO SE MANEJA SIN CUIDADO.

⚠ PRECAUCIÓN: RIESGO DE DAÑO DEL PRODUCTO. NO APIRIETE DE MÁS LOS PERNOS.

- Instale los ganchos de pared de acuerdo con los cálculos de la ilustración.
- Aplique cinta selladora para roscas en las roscas de los tubos e instale el aro hembra en el tubo de desagüe.
- Coloque el empaque en el aro hembra con la superficie biselada al contrario del aro.
- Coloque con cuidado el mingitorio en los ganchos de pared.
- Asegure el mingitorio en el aro hembra con los tornillos y las arandelas provistos.

3 COMPLETE LA INSTALACIÓN

- Instale la válvula de descarga de acuerdo con las instrucciones del fabricante.
- Conecte el suministro de agua y complete las conexiones del tubo de desagüe.
- Abra el suministro de agua.
- Descargue y revise toda la instalación para ver si tiene fugas.

CUIDADO Y LIMPIEZA

Lave con agua y jabón suave y enjuague bien. Seque con un paño suave. Evite los detergentes, desinfectantes y productos de limpieza en latas de aerosol porque pueden dañar los accesorios.

En los Estados Unidos:

American Standard Brands,
P.O. Box 6820
Piscataway, New Jersey 08855
Atención: Director de servicio al cliente
Para los residentes en Estados Unidos,
la información de la garantía
puede obtenerse también llamando al siguiente
número sin cargo: (800) 442-1902
www.americanstandard.com

En Canadá:

AS Canada, ULC
5900 Avebury Rd.
Mississauga, Ontario
Canada L5R 3M3
Número sin cargo: (800) 387-0369
www.americanstandard.ca

En México:

American Standard B&K México,
S. de R.L. de C.V.
Vía Morelos #330
Col. Santa Clara
Ecatepec 55540 Edo. México
Número sin cargo: 01-800-839-1200
www.americanstandard.com.mx

INSTRUCTIONS D'INSTALLATION

American Standard

URINOIR DECORUM

Modèles: 6042, 6043

Nous vous remercions d'avoir choisi American Standard - synonyme de qualité supérieure depuis plus de 100 ans. Pour être sûr que ce produit soit bien installé, veuillez lire attentivement ces instructions avant de commencer. (Certaines installations peuvent requérir une aide professionnelle.) Assurez-vous également que votre installation soit conforme aux codes locaux.

AVANT DE COMMENCER...

⚠ AVERTISSEMENT : CE PRODUIT EST FRAGILE. POUR ÉVITER LES BRIS ET DES BLESSURES, MANIPULER AVEC SOIN !

NOTES :

- Les dessins peuvent ne pas correspondre exactement aux contours de l'appareil ou des composants.
- Respecter tous les codes locaux de plomberie et du bâtiment.
- Se reporter aux codes locaux et aux instructions du fabricant pour les exigences relatives à la valve de chasse.
- Inspecter avec soin le nouvel urinoir afin de déceler tout dommage.
- Les dimensions du robinet sont nominales et sont conformes aux seuils de tolérance établis d'après les normes ASME A112.19.2.
- La préparation du site peut nécessiter des outils et de la quincaillerie supplémentaires.

OUTILS ET MATÉRIAUX RECOMMANDÉS

Lunettes de sécurité Ruban à mesurer Clé universelle Tournevis à lame Crayon Niveaux
 Scellant pour filet Cliquet 1/4 po Équipement pour la découpe de trous

Alimentation Par Le Haut

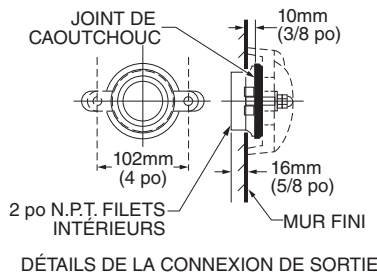
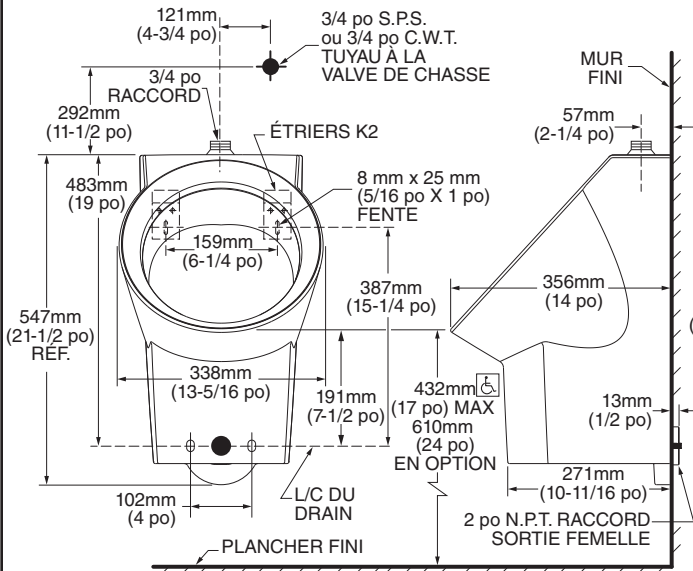

Alimentation Par L'arrière

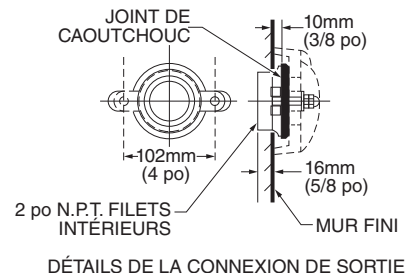
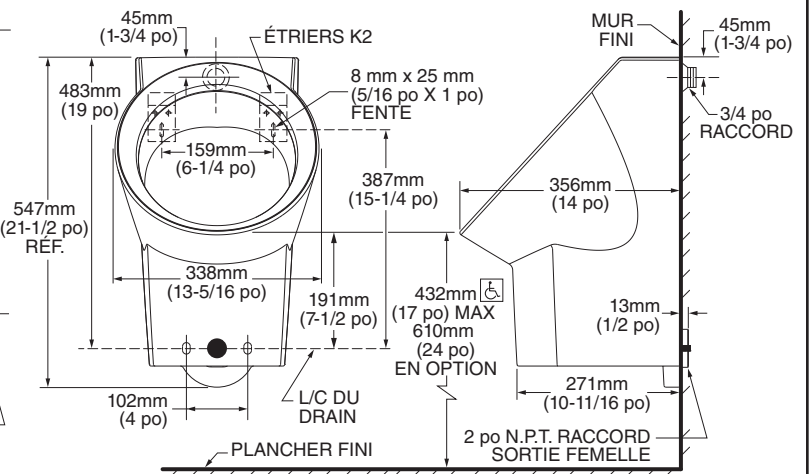

CONSERVER POUR USAGE ULTÉRIEUR

1 PRÉPARATION

- Couper l'alimentation en eau.
- Poser ou relocaliser la conduite d'alimentation et le tuyau de drain au besoin afin de se conformer aux dimensions de l'installation brute.
- Poser la vanne d'arrêt.
- Poser un cadre de soutien adéquat pour les étriers muraux le cas échéant.
- Déterminer la position du mamelon du tuyau de drain. Au moment de déterminer la longueur du mamelon, prendre en considération la longueur de la tête de la sortie de l'urinoir et la distance du filet du collier femelle sur le mamelon du tuyau de drain.

REMARQUE : Ajouter une longueur supplémentaire au mamelon pour laisser l'espace pour le joint.

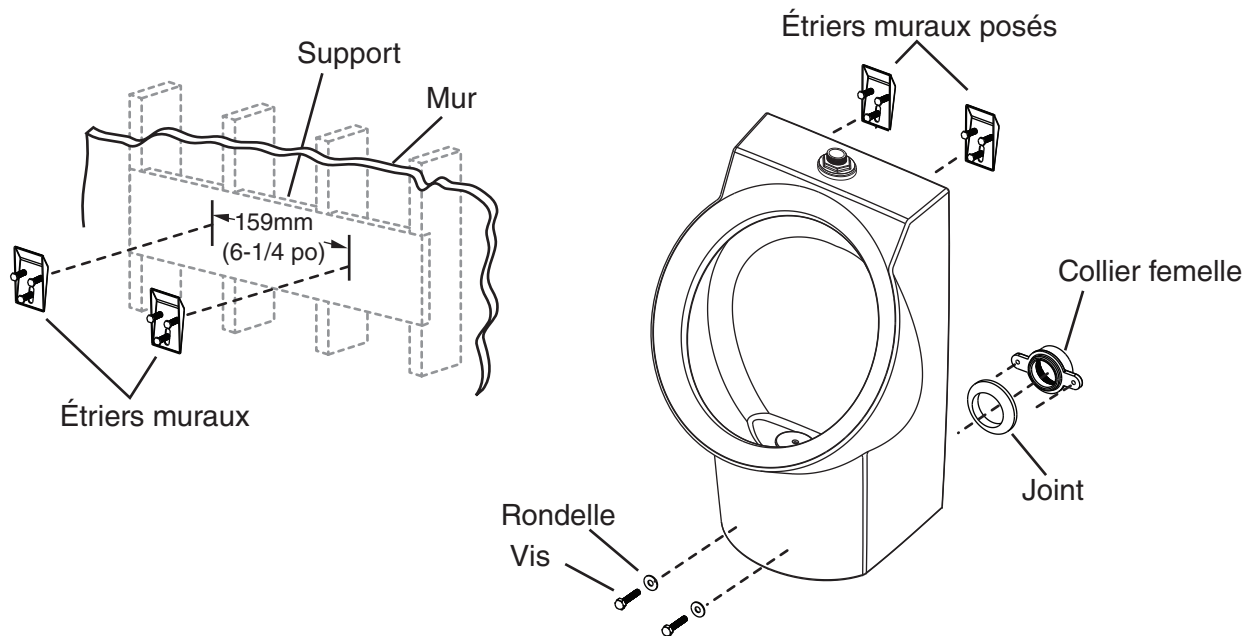

2 INSTALLER L'URINOIR

⚠ AVERTISSEMENT : RISQUE DE BLESSURES CORPORELLES OU DES DOMMAGES AU PRODUIT. MANIPULER AVEC SOIN. LA PORCELAINE VITRIFIÉE PEUT CASSER OU S'ÉCAILLER SI LE PRODUIT N'EST PAS MANIPULÉ AVEC SOIN.

⚠ AVERTISSEMENT : RISQUE DE DOMMAGES AU PRODUIT. ÉVITER DE TROP SERRER LES BOULONS.

- Poser les étriers muraux selon la disposition des tuyaux dans l'illustration.
- Appliquer du ruban scellant sur les filets du conduit et poser le collier femelle sur le tuyau de drain.
- Placer le joint sur le collier femelle avec la surface biseautée faisant face à l'opposé du collier.
- Placer avec soin l'urinoir dans les étriers muraux.
- Fixer l'urinoir au collier femelle en utilisant les vis et les rondelles fournies.

3 TERMINER L'INSTALLATION

- Poser la valve de chasse selon les instructions du fabricant.
- Raccorder l'alimentation en eau et finaliser le raccordement du tuyau de drain.
- Ouvrir l'alimentation en eau.
- Rincer et vérifier l'ensemble de l'installation afin de déceler toute fuite.

ENTRETIEN ET NETTOYAGE

Laver avec de l'eau savonneuse et rincer à fond. Essuyer avec un chiffon doux. Éviter les détergents, les désinfectants ou les produits de nettoyage en aérosol puisqu'ils peuvent endommager les raccords.

Aux États-Unis :

Marques American Standard
P.O. Box 6820
Piscataway, New Jersey 08855
À l'attention de : Directeur du service à la clientèle
Les résidents des États-Unis peuvent aussi obtenir
de l'information sur la garantie en composant
le numéro sans frais suivant : (800) 442-1902
www.americanstandard.com

Au Canada :

AS Canada ULC
5900 Avebury Rd.
Mississauga, Ontario
Canada L5R 3M3

Numéro sans frais : (800) 387-0369
www.americanstandard.ca

Au Mexique :

American Standard B&K Mexico
S. de R.L. de C.V.
Via Morelos n° 330
Col. Santa Clara
Ecatepec 55540 Edo. Mexique
Numéro sans frais : 01-800-839-1200
www.americanstandard.com.mx

SELECTRONIC® DC POWERED PROXIMITY EXPOSED URINAL FLUSH VALVE 0.125, 0.25, 0.5 & 1.0 GPF

MODEL NUMBERS		
6063.013	6064.013	6062.601
6063.025	6064.025	6063.505
6063.051	6064.051	6063.510
6063.101	6064.101	6063.513

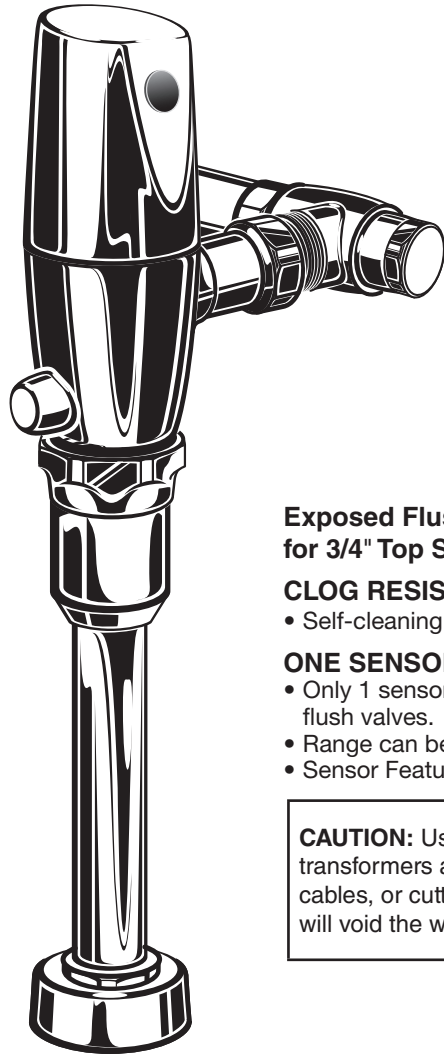

Exposed Flushometer for 3/4" Top Spud Urinals

CLOG RESISTANT

- Self-cleaning piston valve prevents clogging and reduces maintenance.

ONE SENSOR FITS ALL

- Only 1 sensor for entire Selectronic™ line of faucets, urinals, and flush valves.
- Range can be adjusted manually or with optional remote control.
- Sensor Features Low Battery Indicator.

CAUTION: Use only American Standard supplied transformers and cable sets. Using non-AS supplied cables, or cutting, splicing or modifying any components will void the warranty.

Certified to comply with ASME A112.19.2
© 2015 AS America, Inc.

American Standard

NOTE TO INSTALLER: Please give this manual to the customer after installation.

To learn more about American Standard Selectronic® Products visit our website at: www.americanstandard-us.com
or e-mail us at: CRTTEAM@americanstandard.com

For Parts, Service, Warranty or other Assistance,
please call (844) CRT-TEAM / (844) 278-8326 (In Canada: 1-800-387-0369)
(In Toronto Area only: 1-905-306-1093)

American Standard
CRT
Certified Response Technician

Thank you for selecting American-Standard...the benchmark of fine quality for over 100 years. To ensure that your installation proceeds smoothly--please read these instructions carefully before you begin.

UNPACKING

All American Standard Products Are Water Tested At Our Factory. Some Residual Water May Remain In The Valve During Shipping.

Remove the Flush Valve items from the carton. The illustration below shows all items after they have been removed from the carton. Some items may be packaged partially assembled to other items.

- | | |
|----------------------------------|--------------------|
| 1. Installation Instructions | 6. Wall Escutcheon |
| 2. Flush Valve Body Assembly | 7. Cover Tube |
| 3. Vacuum Breaker Tube | 8. Sweat Adapter |
| 4. Spud Coupling Nut and Washers | 9. Stop Valve |
| 5. Spud Flange | |

CARE INSTRUCTIONS:

DO: CLEAN THE PRODUCT WITH CLEAR WATER. DRY WITH A SOFT COTTON FLANNEL CLOTH.

DO NOT: DO NOT CLEAN THE PRODUCT WITH SOAPS, ACID, POLISH, ABRASIVES, HARSH CLEANERS, OR A CLOTH WITH A COARSE SURFACE.

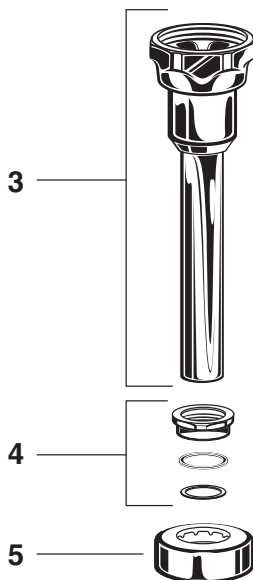
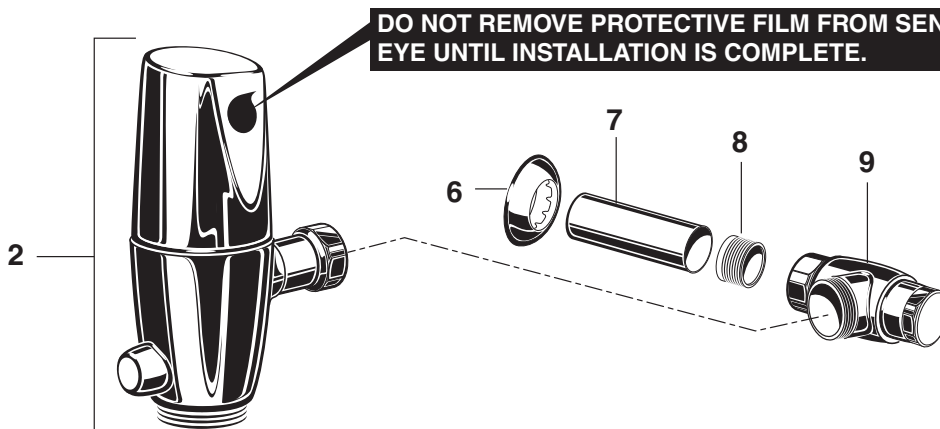

Installation Instructions

SELECTRONIC®
DC POWERED PROXIMITY EXPOSED
URINAL FLUSH VALVE
0.125, 0.25, 0.5 & 1.0 GPF

MODEL NUMBERS		
6063.013	6064.013	6062.601
6063.025	6064.025	6063.505
6063.051	6064.051	6063.510
6063.101	6064.101	6063.513

Exposed Flushometer
for 3/4" Top Spud Urinals

CLOG RESISTANT

- Self-cleaning piston valve prevents clogging and reduces maintenance.

ONE SENSOR FITS ALL

- Only 1 sensor for entire Selectronic™ line of faucets, urinals, and flush valves.
- Range can be adjusted manually or with optional remote control.
- Sensor Features Low Battery Indicator

CAUTION: Use only American Standard supplied transformers and cable sets. Using non-AS supplied cables, or cutting, splicing or modifying any components will void the warranty.

Offered in comply with ASME A112.19.2
© 2015 AS America, Inc.

American Standard

NOTE TO INSTALLER: Please give this manual to the customer after installation.
To learn more about American Standard Selectronic® Products visit our website at: www.americanstandard-us.com
or e-mail us at: CRTEAM@americanstandard.com

For Parts, Service, Warranty or other Assistance,
please call (844) CRT-TEAM / (844) 278-8326 (In Canada: 1-800-387-0369)
(In Toronto Area only: 1-905-306-1053)

Certified Pipefitter Technician

Roughing-in Dimensions Fig. 1

Right or Left Hand Installation

See (Section 5) for converting Flush Valve to Left Hand Installation.

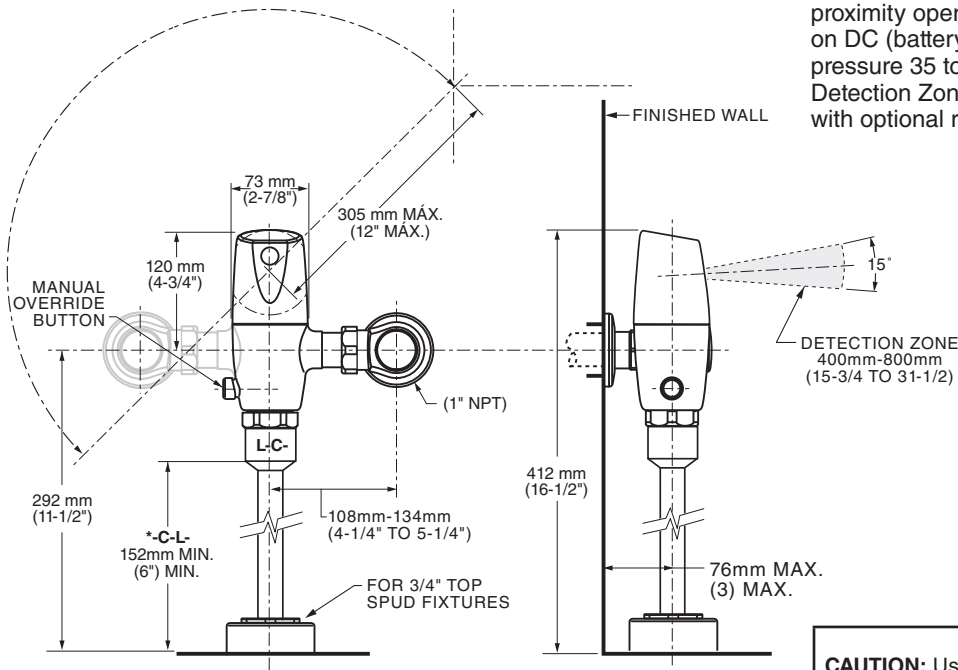

*Note: The Critical Line (-C-L-) on Vacuum Breaker must typically be 6" (152mm) above fixture. Consult Codes for details.

GENERAL DESCRIPTION:

SELECTRONIC™ PROXIMITY URINAL FLUSH VALVE Exposed Flushometer for 3/4" Top Spud Fixtures

Exclusive, self cleaning piston-type flush valve with proximity operation and manual override. Operates on DC (battery) power. Recommended operating pressure 35 to 80 psi. Can install left or right-handed. Detection Zone can also be adjusted manually, or with optional remote control.

CAUTION: Use only American Standard supplied transformers and cable sets. Using non-AS supplied cables, or cutting, splicing or modifying any components will void the warranty.

RECOMMENDED TOOLS; Fig. 2.

1. Teflon Tape
2. Flat Blade Screwdriver
3. Adjustable Wrench
4. Tape Measure
5. Hacksaw
6. Tubing Cutter
7. File
8. For Sweat Connection; Solder and Torch
9. 2.5mm Hex Wrench
10. 1.5mm Hex Wrench

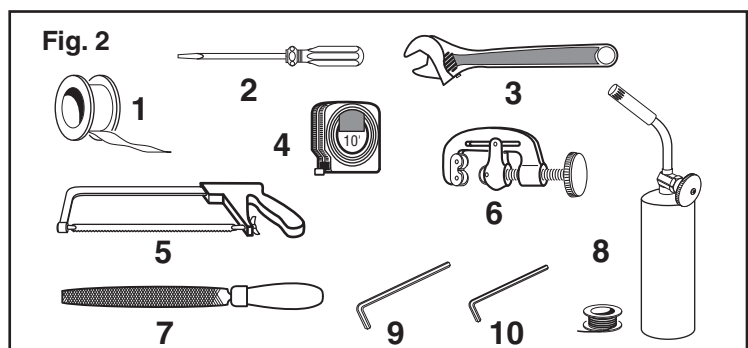

PRIOR TO INSTALLATION

Note: Prior to installing the Selectronic™ Flush Valve the following items must be installed.

1. Urinal
2. Drain line
3. Water supply line

IMPORTANT:

- All plumbing and electrical wiring should be installed in accordance with applicable codes and regulations.
- The use of water hammer arrestors is strongly recommended for commercial applications. All piping behind the walls should be properly secured and fastened.
- Water supply lines must be sized to provide an adequate volume of water for each fixture.

- Flush all water lines prior to operation (See Step 4). Dirt and debris can cause flush valve to run continuously.
- With the exception of Stop Valve Inlet, DO NOT use pipe sealant or plumbing grease on any valve component or coupling!
- Protect the chrome or special finish on the Flushometer. DO NOT USE toothed tools on finished surfaces to install or service these valves. Also see "Care and Cleaning" section of this manual.
- This product contains mechanical and/or electrical components that are subject to normal wear. These components should be checked on a regular basis and replaced as needed to maintain the valve's performance.

FLUSH VALVE INSTALLATION

1 INSTALL SWEAT ADAPTER; Fig. 3

CAUTION Turn water supplies off before beginning

Note: *Install Optional Sweat Adapter (Supplied) for copper pipe supply line.*

1. Measure the distance (A) from the finished wall to the center of the inlet spud on the fixture.
2. Cut the supply pipe 1-1/4" (A-B=C) shorter than the measurement taken in Step 1. File any rough edges off the end of the supply pipe.
3. Clean the end of the supply pipe. Push the threaded Adapter until it is seated against the internal stop. Sweat the Adapter to the pipe.

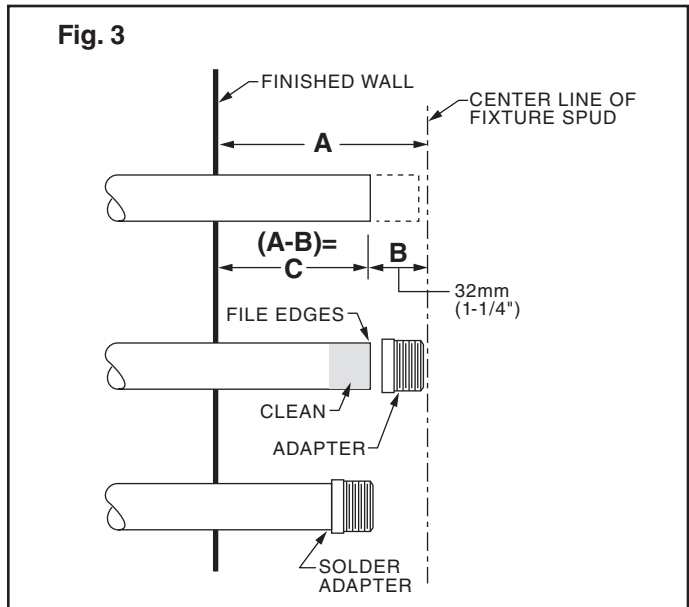

2 INSTALL COVER TUBE, WALL ESCUTCHEON and STOP VALVE; Fig. 4

1. Measure from finished wall to first thread of Adapter or threaded supply pipe (dimension "X"). Cut COVER TUBE (1) to length (X). Apply Teflon Tape to the threaded end of the Adapter or supply pipe.
2. Push WALL ESCUTCHEON (2) onto the COVER TUBE (1). Slide both onto the SUPPLY PIPE (3).
3. Push the COVER TUBE (1) in to expose the threads of the supply pipe. With a wrench thread the STOP VALVE (4) onto the SUPPLY PIPE (3). Align and tighten.
4. Pull COVER TUBE (1) against STOP VALVE (4) and push WALL ESCUTCHEON (2) against finished wall.

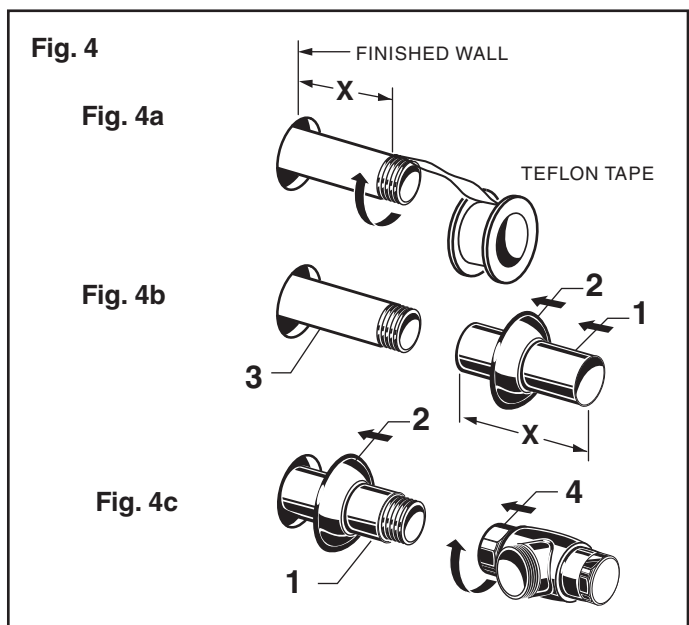

3 INSTALL VACUUM BREAKER TUBE; Fig. 5

1. Place the SPUD FLANGE (1) over the spud on the Fixture.
2. Place FRICTION WASHER (3) and SEAL WASHER (4) inside SPUD COUPLING NUT (2) and thread onto Spud. Do not tighten fully.
3. Insert the VACUUM BREAKER TUBE (5) into the SPUD COUPLING NUT (2) and push it down.

Note: *If cutting VACUUM BREAKER TUBE (5) to size, note that Critical Line (C/L) on Vacuum Breaker must typically be 6" (152mm) above fixture. Consult Code for details.*

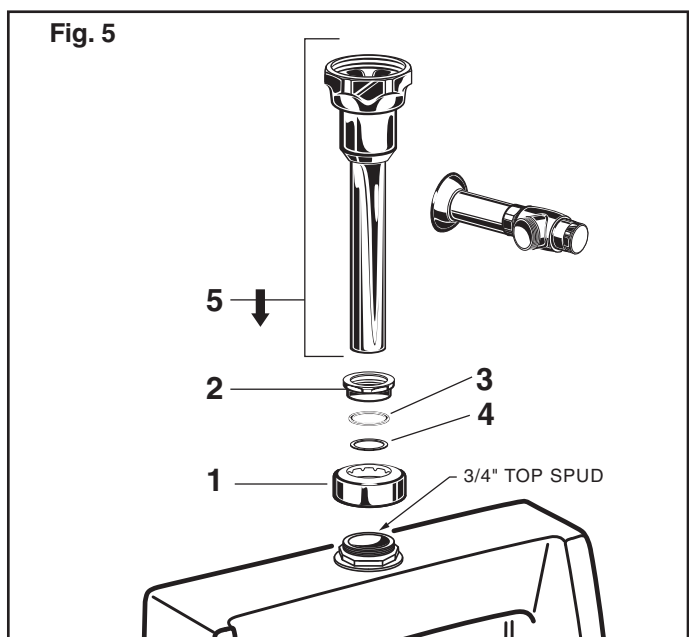

4 FLUSH OUT SUPPLY LINES; Fig. 6

1. Remove STOP VALVE COVER (1) from STOP VALVE (2).
2. Open STOP VALVE (2) with a flat blade screwdriver.
3. Turn on water supply to flush line of any debris or sediment.
4. Close STOP VALVE (2) and replace STOP VALVE COVER (1).

5 LEFT OR RIGHT HAND INSTALLATION; Fig. 7

The unit is shipped with adjustable tailpiece on the right side. If needed, the orientation can be modified by following the steps below.

1. Loosen SET SCREW (1) with 2.5mm Hex Wrench (4) in back of FLUSH VALVE COVER (2).
2. Rotate FLUSH VALVE COVER (2) to the right and pull off.
3. Rotate FLUSH VALVE BODY (3) 180°.
4. Replace COVER (2) and rotate until key engages. Tighten SET SCREW (1).

6 INSTALL FLUSH VALVE; Fig. 8, 8a

1. Insert ADJUSTABLE TAILPIECE (1) into the STOP VALVE (2). Lubricate the O-RING (3) with water if necessary. Lightly tighten COUPLING NUT (4). Fig. 8.

Important: Do not use lubricants (other than water) or any type of thread sealing paste or tape.

2. Align the FLUSH VALVE BODY (5) directly above the VACUUM BREAKER TUBE (7) and VACUUM BREAKER COUPLING NUT (6). Fig. 8a.

Note: There is a +13mm, -6mm (+1/2, -1/4) tolerance for the 121mm (4-3/4) dimension. Fig. 8a.

3. Pull the VACUUM BREAKER TUBE (7) up to meet the threaded FLUSH VALVE BODY (5), hand tighten the VACUUM BREAKER COUPLING NUT (6). Align all components of the flush valve assembly. Fig. 8a.
4. Lightly tighten the COUPLING NUT (4) connection first, then the VACUUM BREAKER COUPLING NUT (6) and finally the SPUD COUPLING NUT (8). Once aligned correctly, use a wrench to tighten couplings to make water tight connections. Fig. 8a.

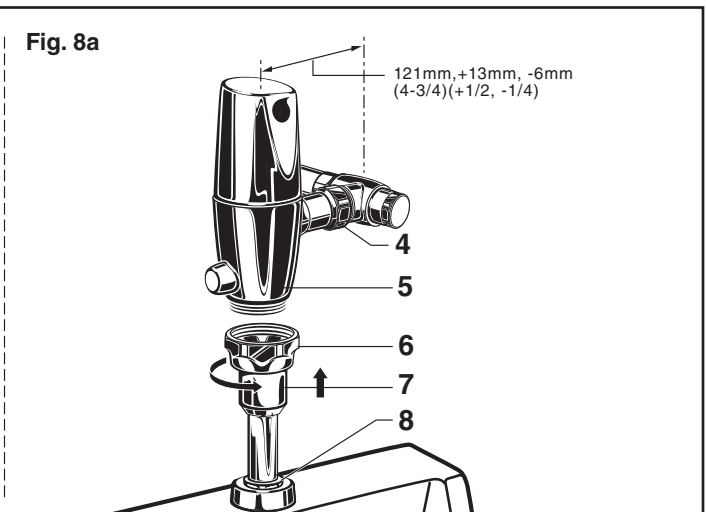
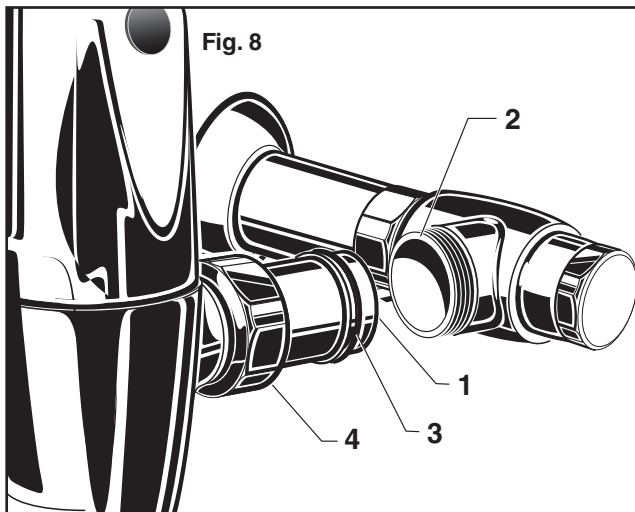
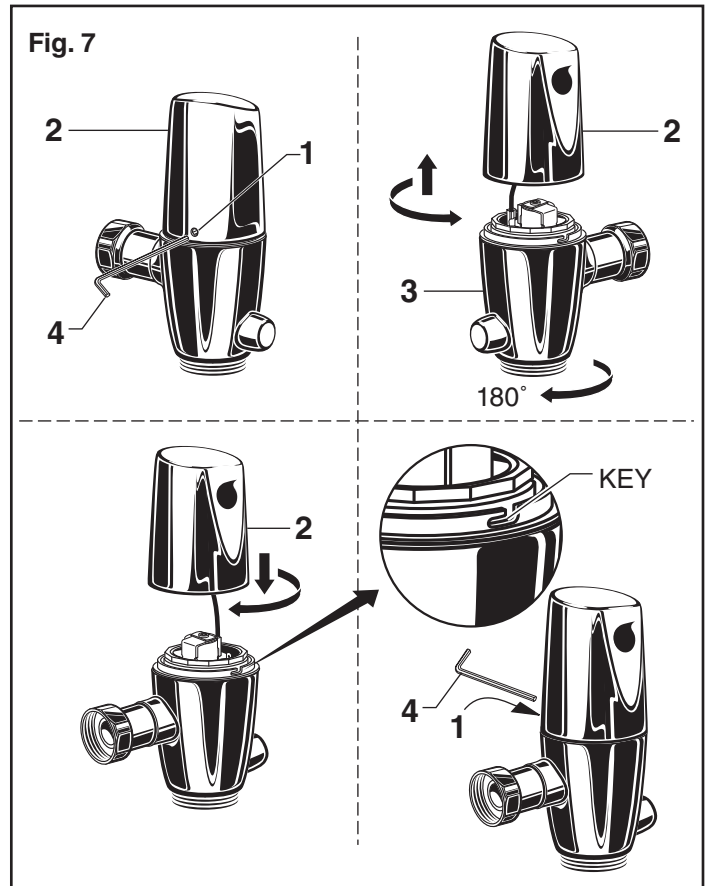
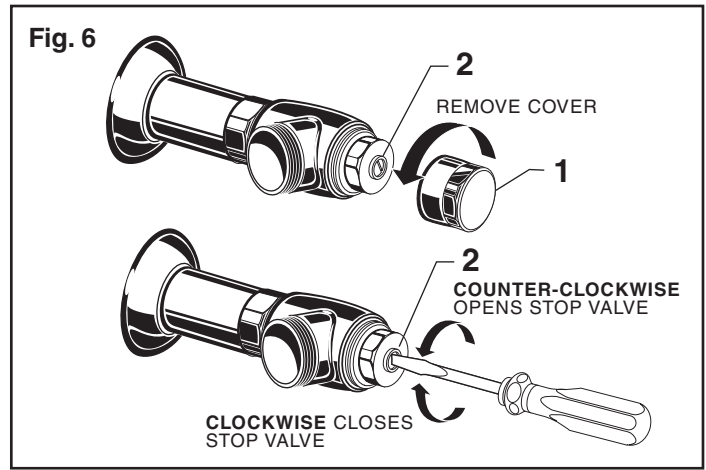

MAINTENANCE

A ADJUST STOP VALVE; Fig. 9

IMPORTANT: To avoid overflowing, the STOP VALVE (3) must never be opened to the point where the flow from the valve exceeds the flow capacity of the fixture.

1. After installation is complete, peel off the PROTECTIVE FILM (1) from the sensor. Standing to one side, block the sensor with your hand for 10 seconds. Remove your hand and listen for audible “click” from within the valve.
2. Remove STOP VALVE COVER (2) from STOP VALVE (3). Turn on water supply 1/4 turn to 1/2 turn (CCW) and test for leaks.

Note: Unit may flush for approximately 5 to 10 sec. when water is first turned on. If flow persists, turn water off and repeat step #1 above.

3. Actuate the FLUSH VALVE:

- A) Cover sensor with hand for 10 seconds.

NOTE: Stand outside of sensor detection area.

- B) Remove hand from in front of the sensor; unit will flush in approximately 3 seconds.

4. Adjust STOP VALVE (3) after each flush until the stated flush volume is achieved, no splashing occurs and the fixture is properly cleansed.
5. When adjustment is complete, replace STOP VALVE COVER (2) and tighten to ensure vandal-resistance.

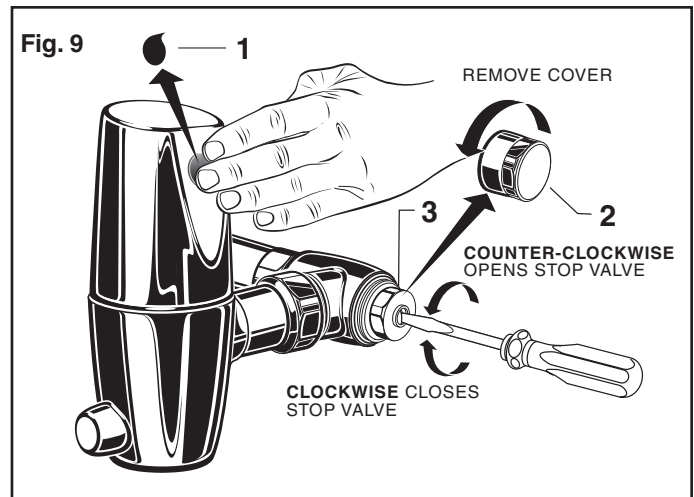

B RETROFITTING WITH SELECTRONIC VALVE; Fig. 10

(Replaces Industry Standard Manual and Electronic Valves)

Note: In most Retrofits the wall escutcheon, stop valve, cover tube and vacuum breaker do not have to be replaced. If these items do need replacement they must be purchased separately or order the complete flush valve assembly from American Standard.

1. Remove STOP VALVE COVER (1) from STOP VALVE (2).
2. Turn water supply off.
3. Loosen SPUD COUPLING NUT (3). Unthread COUPLING NUT (4) and VACUUM BREAKER COUPLING NUT (5). Remove FLUSH VALVE (6).
4. Clean all threaded connections before installing the new flush valve.
5. Refer to Sections 4, 5 and 6 to complete the retrofit installation.

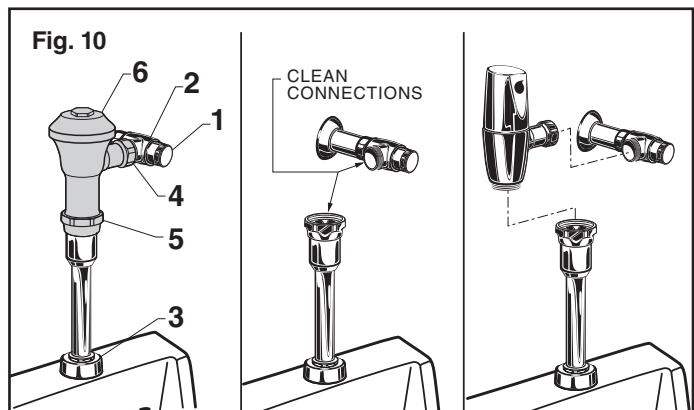

C REPLACE BATTERY; Fig. 11, 11a

1. Loosen SET SCREW (1) with 2.5mm Hex Wrench (2) in back of FLUSH VALVE COVER (3). **Fig. 11.**
2. Rotate COVER (3) to the right and pull off. **Fig. 11.**
3. Turn COVER (3) over and disconnect the SENSOR (4) from the BATTERY HOLDER (5). Remove the BATTERY CONTAINER (6) with BATTERY HOLDER (5) and BATTERY (7) inside. **Fig. 11a.**
4. Remove BATTERY HOLDER (5) from BATTERY CONTAINER (6). **Fig. 11a.**
5. Remove old BATTERY from BATTERY HOLDER (5). Install the new BATTERY (7) making sure the shape of the BATTERY follows the shape of the BATTERY HOLDER (5). **Fig. 11a.**
6. Insert BATTERY HOLDER (5) with BATTERY into BATTERY CONTAINER (6). Insert BATTERY CONTAINER (6) into flush valve COVER (3). **Fig. 11a.**
7. Connect BATTERY HOLDER (5) to SENSOR (4) and reverse the above steps to assemble flush valve. **Fig. 11a.**

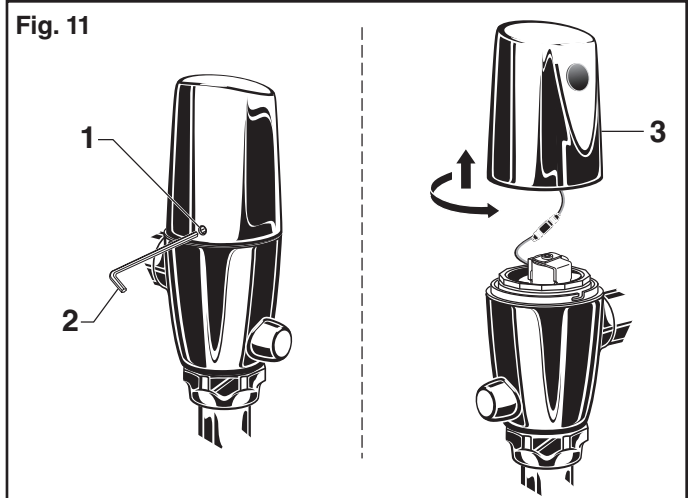
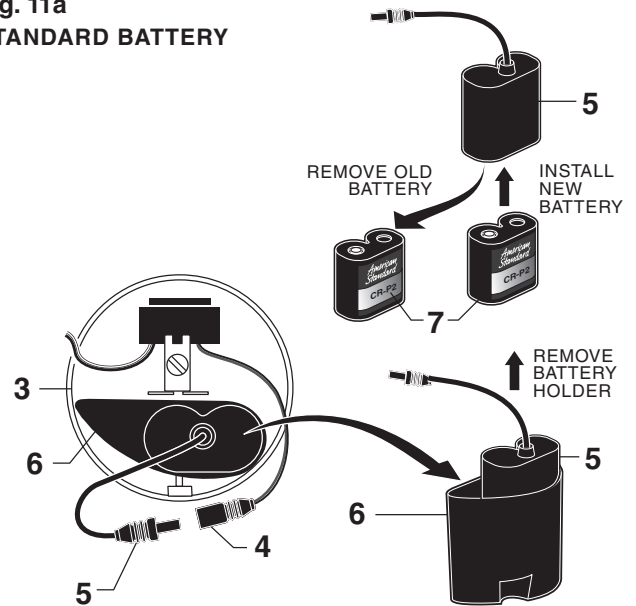

Fig. 11a
STANDARD BATTERY



D REPLACE LONG LIFE POWER PACK; Fig. 11, 11b

1. Loosen SET SCREW (1) with 2.5mm Hex Wrench (2) in back of FLUSH VALVE COVER (3). **Fig. 11.**
2. Rotate COVER (3) to the right and pull off. **Fig. 11.**
3. Turn COVER (3) over and disconnect SENSOR (4) from LONG LIFE POWER PACK (8). **Fig. 11b.**
4. Remove old LONG LIFE POWER PACK (8) and insert new unit. **Fig. 11b.**
5. Connect new LONG LIFE POWER PACK (8) to SENSOR (4). Reverse the above steps to assemble flush valve. **Fig. 11b.**

Fig. 11b
LONG LIFE POWER PACK

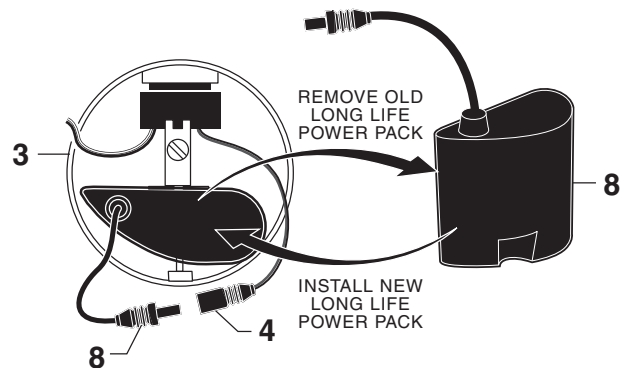

E SET DETECTION RANGE (If Required); Fig. 13 & 14

Note: *The detection distance is preset and ideal for most installations. Should an adjustment be required, follow the steps below.*

1. Loosen SET SCREW (1) with 2.5mm Hex Wrench (2) in back of FLUSH VALVE COVER (3). Fig. 13a.
2. Rotate COVER (3) to the right and pull off. Fig. 13b.
3. Turn COVER (3) over and disconnect CABLE (4) from BATTERY HOLDER (5). Fig. 13.
4. Keeping hands away from the sensor detection area, reconnect the SENSOR (4) and quickly place the COVER (3) on the valve. Do not secure the COVER (3) at this time.

Note: *You have 5 seconds to begin entering the program code after power connection is made.*

5. While the SENSOR CONTROL LED (1) is blinking slowly, place your hand 1 to 2 in. (30-50mm.) in front of the sensor. Fig. 14.
6. When the LED (1) stops blinking and stays "ON," move your hand to the desired position and hold in place until the LED (1) begins to blink again. Fig. 14.

Note: *Detection Zone is 400mm - 800mm.
(Factory Setting: 400mm)*

7. Once the SENSOR CONTROL LED (1) begins to blink again, remove your hand from the detection zone. When the flashing stops, the detection distance is set.
8. Replace and secure COVER (3) onto valve.
9. Actuate the FLUSH VALVE:

A) Cover sensor with hand for 10 seconds.

NOTE: *Stand outside of sensor detection area.*

B) Remove hand from in front of the sensor; unit will flush in approximately 3 seconds.

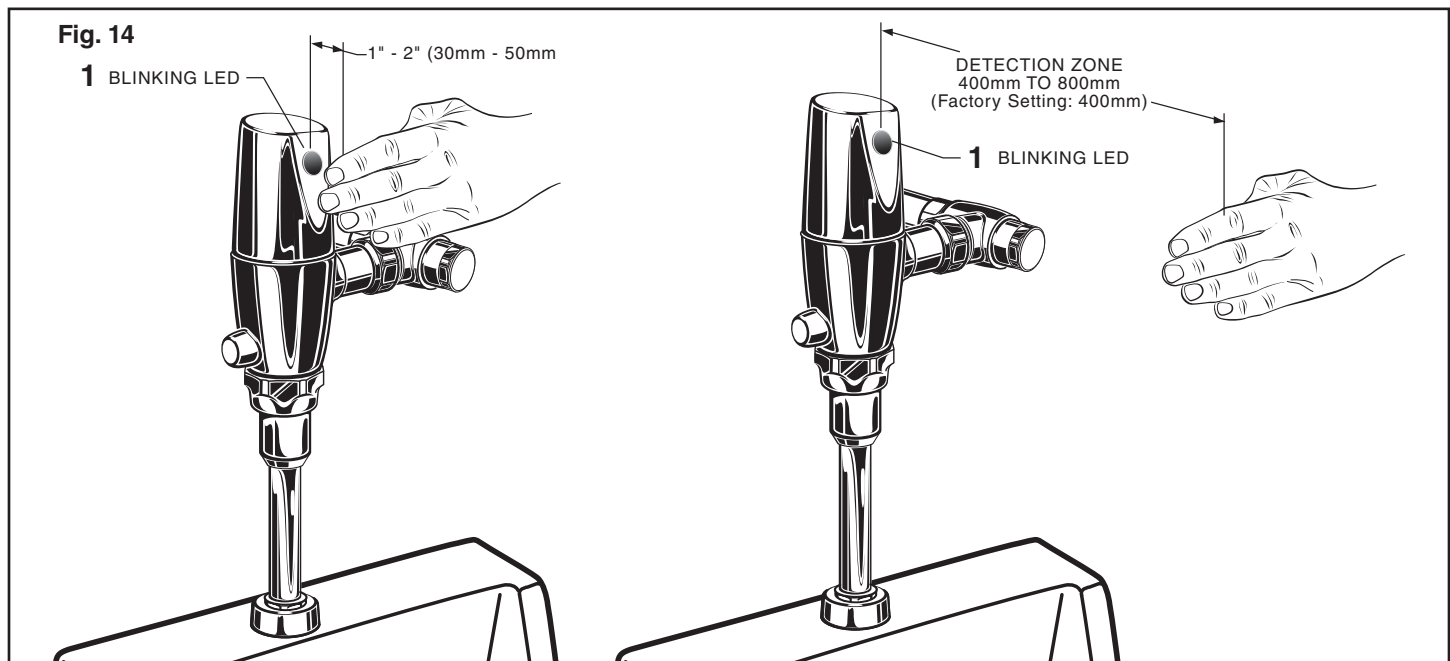
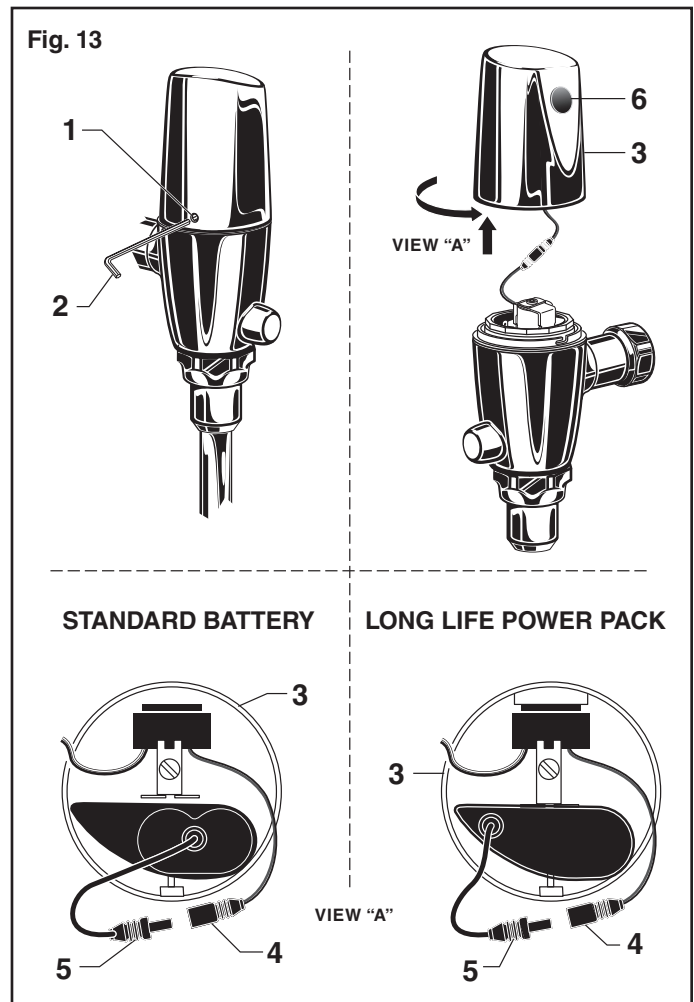

TROUBLESHOOTING FLOW CHARTS

UNIT DOES NOT FUNCTION

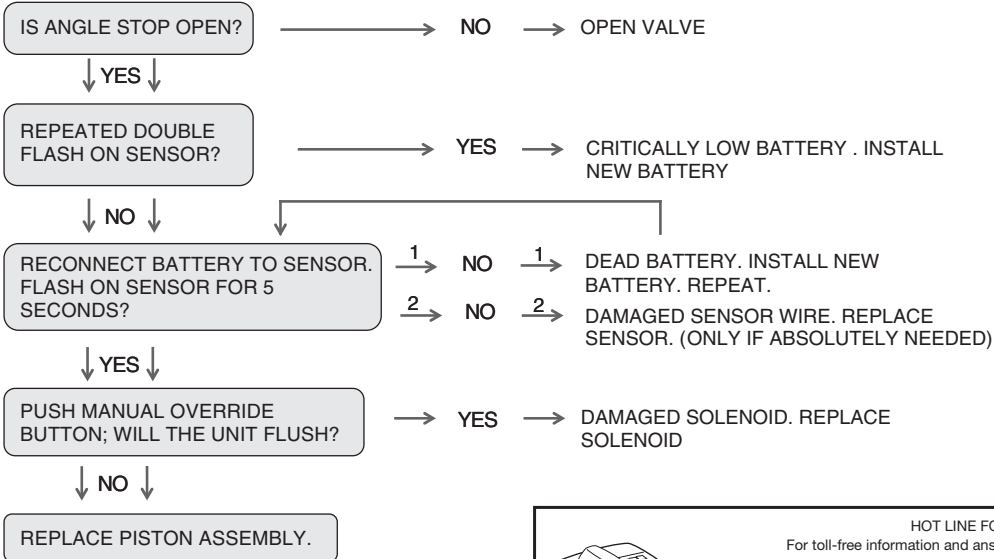



HOT LINE FOR HELP
 For toll-free information and answers to your questions, call:
 (844) CRT-TEAM / (844) 278-8326
 Mon. - Fri. 8:00 a.m. to 8:00 p.m. EST Saturday 10:00 a.m. to 4:00 p.m. EST
 IN MEXICO 01-800-839-1200
 IN CANADA 1-800-387-0369 (TORONTO 1-905-306-1093)
 Weekdays 8:00 a.m. to 7:00 p.m. EST

Product names listed herein are trademarks of AS America, Inc. ©2015

To learn more about American Standard Selectronic® Products visit our website at: www.americanstandard-us.com or e-mail us at: CRTTEAM@americanstandard.com

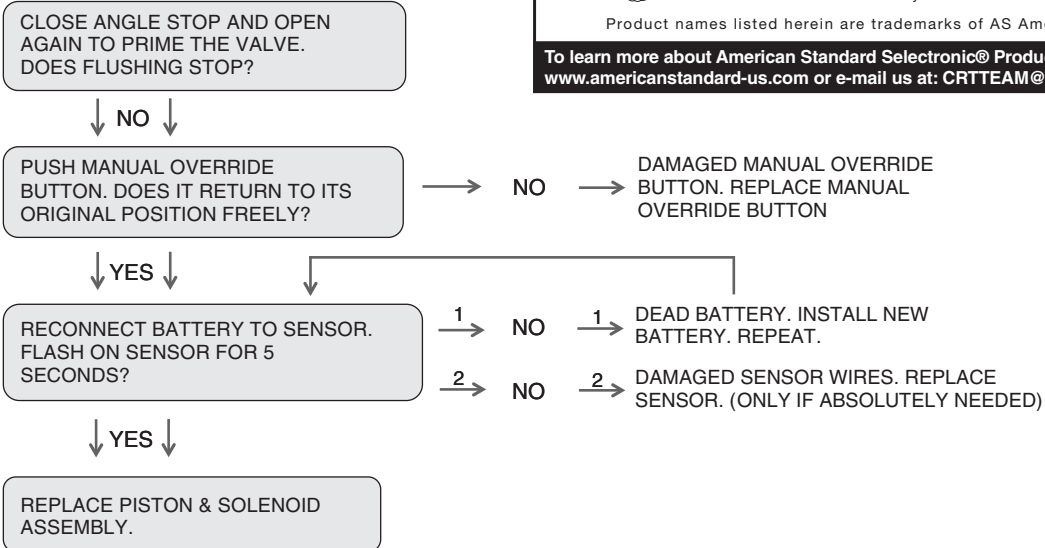
UNIT WILL ONLY FLUSH MANUALLY



UNIT IS CONTINUOUSLY FLUSHING

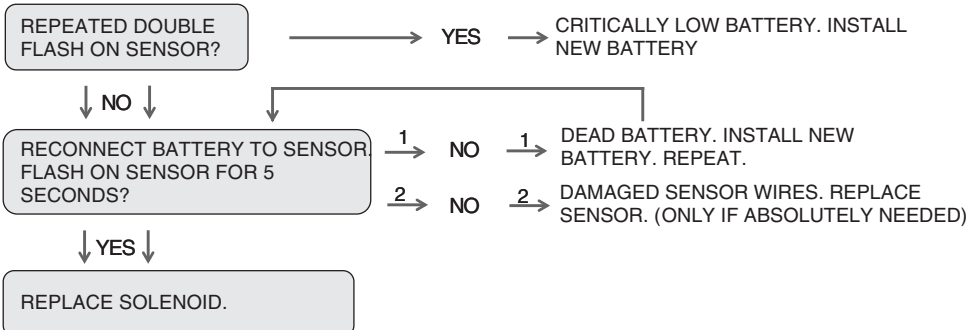

SELECTRONIC® DC POWERED PROXIMITY EXPOSED URINAL FLUSH VALVE 0.125, 0.25, 0.5 & 1.0 GPF

Standard Battery (6063. Series)	Long Life Power Pack (6064. Series)
<p>M964942-0020130A COVER ASSEMBLY (0.125 gpf)</p> <p>M964942-0020250A COVER ASSEMBLY (0.25 gpf)</p> <p>M964942-0020500A COVER ASSEMBLY (0.5 gpf)</p> <p>M964942-0021000A COVER ASSEMBLY (1.0 gpf)</p>	<p>M964949-0020130A COVER ASSEMBLY (0.125 gpf)</p> <p>M964949-0020250A COVER ASSEMBLY (0.25 gpf)</p> <p>M964949-0020500A COVER ASSEMBLY (0.5 gpf)</p> <p>M964949-0021000A COVER ASSEMBLY (1.0 gpf)</p>
<p>A917376-0070A SET SCREW</p> <p>M906684-0070A BONNET NUT</p>	<p>A917376-0070A SET SCREW</p> <p>M906684-0070A BONNET NUT</p>
<p>M964802-0070A SOLENOID & PISTON SUBASSEMBLY</p> <p>M964302-0070A SOLENOID ASSEMBLY</p> <p>M964801-0070A PISTON ASSEMBLY</p>	<p>M964947-0070A SOLENOID & PISTON SUBASSEMBLY</p> <p>M964948-0070A SOLENOID ASSEMBLY</p> <p>M964946-0070A PISTON ASSEMBLY</p>

MODEL NUMBERS		
6063.013	6064.013	6062.601
6063.025	6064.025	6063.505
6063.051	6064.051	6063.510
6063.101	6064.101	6063.513

M950319-0070130A
SENSOR ASSEMBLY (0.125 gpf)

M950319-0070300A
SENSOR ASSEMBLY (0.25 gpf)

M950319-0070500A
SENSOR ASSEMBLY (0.5 gpf)

M950319-0071000A
SENSOR ASSEMBLY (1.0 gpf)



Power Source

Standard Battery 6063. Series

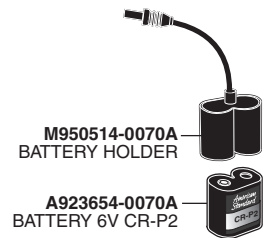

Long Life Power Pack 6064. Series



M950354-0020A
MANUAL VALVE

M964402-0070A
VACUUM BREAKER KIT

M962801-0070A
FLOW REGULATOR
(Before July 2015)

M923189-0070A
FLOW REGULATOR
(After July 2015)

M964412-0020A
3/4" VACUUM
BREAKER ASSEMBLY

M955062-0020A
1-1/4" VACUUM
BREAKER ASSEMBLY
FOR (6062.601)

M952262-0020A
3/4" SPUD ASSEMBLY

M952208-0020A
1-1/4" SPUD ASSEMBLY
FOR (6062.601)

A912809-0070A
O-RING

M964945-0020A
ADJUSTABLE TAILPIECE
(4-1/4" to 5-1/4" Rough-in)

OPTIONAL ADJUSTABLE TAILPIECE
(Purchased Separately)

M962836-0020A (8-1/4" to 9-1/4" Rough-in)

M962835-0020A (7-1/4" to 8-1/4" Rough-in)

M962834-0020A (6-1/4" to 7-1/4" Rough-in)

M962833-0020A (5-1/4" to 6-1/4" Rough-in)

A955057-0020A
1" INLET PIPE ASSEMBLY
FOR (6062.601)

M952261-0020A
3/4" INLET PIPE ASSEMBLY

M962926-0070A
1" SWEAT ADAPTER

M964075-0070A
3/4" SWEAT ADAPTER

A955056-0020A
1" STOP VALVE KIT

M955058-0020A
3/4" STOP VALVE KIT

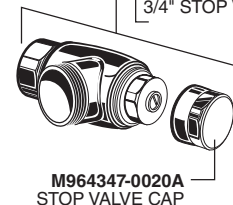

HOT LINE FOR HELP
For toll-free information and answers to your questions, call:
(844) CRT-TEAM / (844) 278-8326
Mon. - Fri. 8:00 a.m. to 8:00 p.m. EST Saturday 10:00 a.m. to 4:00 p.m. EST
IN MEXICO 01-800-839-1200
IN CANADA 1-800-387-0369 (TORONTO 1-905-306-1093)
Weekdays 8:00 a.m. to 7:00 p.m. EST

Product names listed herein are trademarks of AS America, Inc. ©2015

To learn more about American Standard Selectronic® Products visit our website at:
www.americanstandard-us.com or e-mail us at: CRTEAM@americanstandard.com