

Installation Instructions

SELECTRONIC® I.C. Faucet

MODEL NUMBERS

6053.193

6055.193

605B.193



I.C. Faucet shown installed on
American Standard 9118.111 Sink

CAUTION: Use only American Standard supplied transformers and cable sets. Using non-AS supplied cables, or cutting, splicing or modifying any components will void the warranty.

Product No.'s & Options	1
Specifications	2
Faucet Installation	2-3
Electrical Installation	4-6
Start-up / Maintenance	7-8
FAQ's / Troubleshooting	9-10
Parts	11

Certified to comply with:
• ASME A112.18.1

American Standard

NOTE TO INSTALLER: Please give this manual to the customer after installation.

To learn more about American Standard Selectronic® Products visit our website at: www.americanstandard-us.com
or e-mail us at: CRTTEAM@americanstandard.com

For Parts, Service, Warranty or other Assistance,
please call (844) CRT-TEAM / (844) 278-8326 (In Canada: 1-800-387-0369)
(In Toronto Area only: 1-905-306-1093)

American Standard
CRT
Certified Response Technician

Thank you for selecting American-Standard...the benchmark of fine quality for over 100 years. To ensure that your installation proceeds smoothly--please read these instructions carefully before you begin.

UNPACKING All American Standard Products Are Water Tested At Our Factory. Some Residual Water May Remain In The Valve During Shipping

The illustration below shows the fitting and all loose items after they have been removed from the carton. Some items may be packaged partially assembled to other items.

- 1. Installation Instructions
- 2. Spout Assembly
- 3. Mounting Kit
- 4. Control Box
- 5. Supply Hose
- 6. 4" Deck plate (optional, must be ordered separately)
- 7. 8" Deck plate (optional, must be ordered separately)
- 8. Mixing Valve (optional, must be ordered separately)
- 9. Control Box Cover Screws

Base Product	<p>PRODUCT No.s 605X.193</p>	POWER KITS SOLD SEPARATELY		
		<p>Plug-In AC Power Kit PK00.PAC</p>	<p>Hard-Wired AC Power Kit PK00.HAC</p>	<p>Multi-AC Power Kit PK00.MAC</p>
	<p>Deck Plate</p> <p>605P400</p> <p>605P800</p>			
<p>Mixing Valve</p> <p>605XTMV</p>				

Roughing-in Dimensions

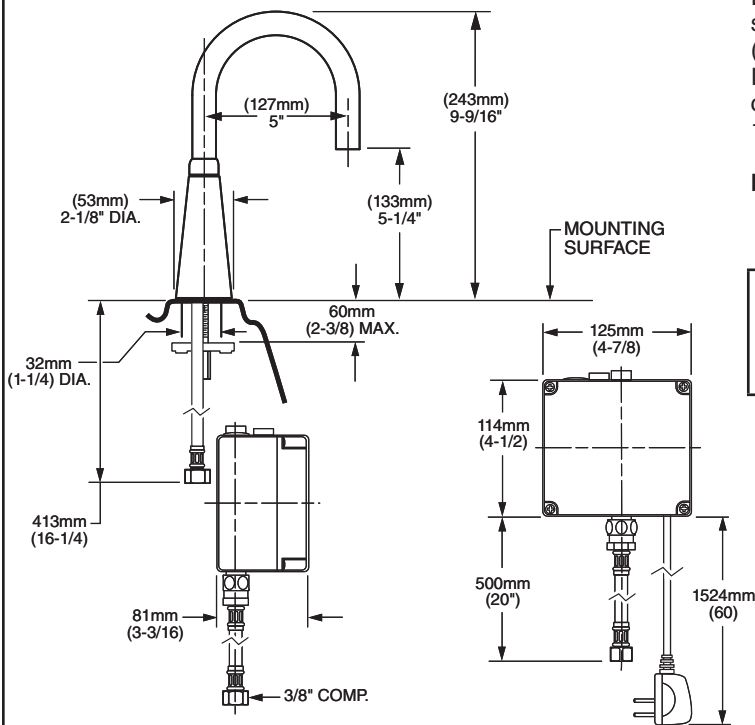

GENERAL DESCRIPTION

Electronic faucet with proximity operation. Vandal resistant, solid brass construction, single post mounting. Operates on DC (battery/power pack) or AC permanent power (plug-in/hardwire). In-line strainer for solenoid is integral. Single inlet 3/8 compression, built-in check valves, and flexible stainless steel 16-1/4" reach inlet hose for spout connection.

Note: All plumbing and electrical wiring must be installed in accordance with applicable codes, regulations and standards.

CAUTION: Use only American Standard supplied transformers and cable sets. Using non-AS supplied cables, or cutting, splicing or modifying any components will void the warranty.

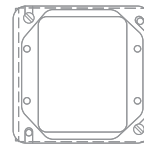

RECOMMENDED ELECTRICAL BOX OR EQUIVALENT BY OTHERS
4" (102mm) SQ. X 3-1/2" (89mm) DEEP ELECTRICAL BOX
Hubbel-RACO #256 OR EQUAL (BY OTHERS).

HARD-WIRED AND MULTI AC 10' MAX. CABLE LENGTH

RECOMMENDED TOOLS

1. Slip Joint Pliers
2. Adjustable Wrench
3. Plumbers' Putty or Caulking
4. Phillips Screwdriver
5. Flat Blade Screwdriver
6. Electric Drill & 1/4" Drill Bit
7. Tape Measure

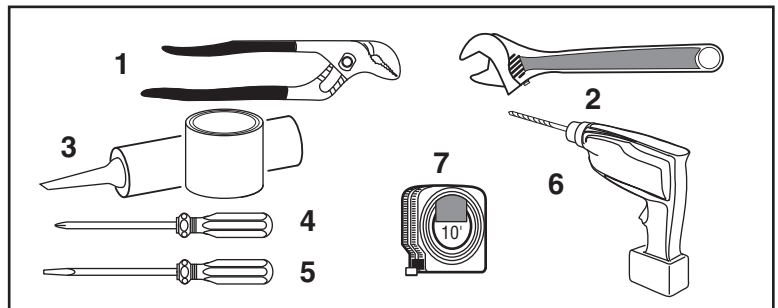

FAUCET INSTALLATION

1 SPOUT ASSEMBLY INSTALLATION; Fig. 1

CAUTION Turn off hot and cold water supplies before beginning.

1. Insert CABLES (1), FLEX HOSE (2) and SPOUT SHANK (3) through center hole of mounting surface.
2. Assemble "C" WASHER (4) and LOCKNUT (5) onto SPOUT SHANK (3) from underside of mounting surface.
3. Align FAUCET and tighten LOCKNUT (5).

Note: 4" and 8" Deck Plates are available for other installations, see page one for information.

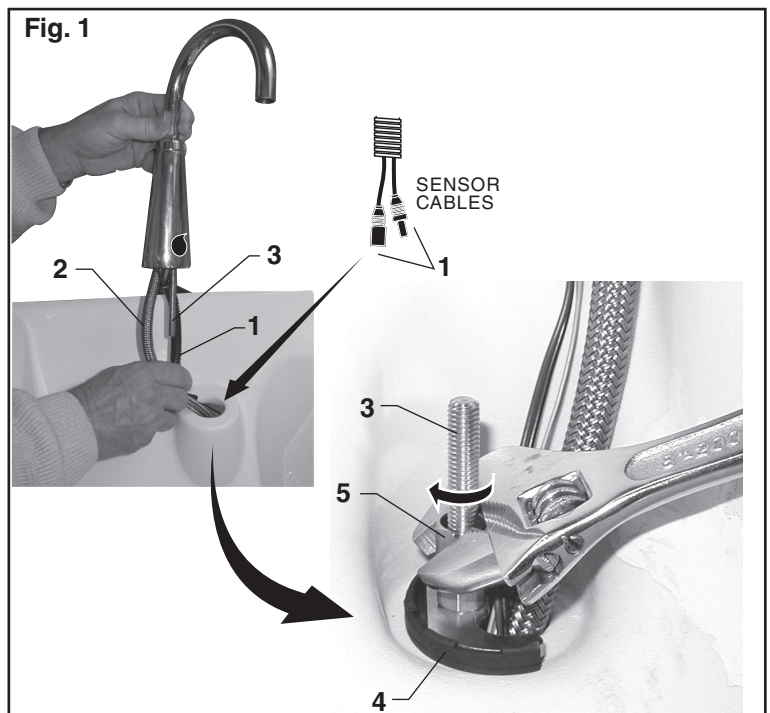

2 MOUNT CONTROL BOX; Fig. 2

NOTE: The illustration shows the Infection Control faucet mounted on the American Standard Infection Control Sink. Faucet can be installed on any sink or countertop. For further instructions regarding faucet installation on the American Standard Infection Control Sink, see instruction sheet No. 7301793-100 (Infection Control Sink System) supplied with Sink.

1. For installation on Infection Control Sink, mount CONTROL BOX (1) on MOUNTING BRACKET (2) with the SCREWS (3) provided.
2. For all other sinks or countertops, determine location of CONTROL BOX (1). It must be located within the 14" (356mm) by 21" (533mm) shaded area shown in **Figure 2** in order for electrical connections from the spout assembly to be made properly.

NOTE: CONTROL BOX SUPPLY HOSE is 20". Distance between wall supply and CONTROL BOX (1) must be taken into consideration.

3. Remove tape from CONTROL BOX COVER (6) and pull off COVER (6). Hold the CONTROL BOX (1) in desired location and mark the four mounting hole locations as shown.

NOTE: Find plastic bag containing 4 M5X16 screws to be used for securing the CONTROL BOX (1) when installation is complete.

NOTE: For AC installation, make power supply connection before mounting CONTROL BOX (1) to wall.

4. It is recommended that the CONTROL BOX (1) be secured to a wall stud or cross brace within the wall using the SCREWS (3) supplied. If the CONTROL BOX (1) is to be installed on tile or plaster walls, the ANCHORS (5) and SCREWS (4) should be used.

3 CONNECT SPOUT HOSE TO CONTROL BOX; Fig. 3

1. Connect SUPPLY NUT (1) from spout hose to nipple on top of CONTROL BOX (2). Tighten with adjustable wrench to make a water tight connection. **Fig. 3.**

4 CONNECT WATER SUPPLY TO CONTROL BOX AND WALL SUPPLY; Fig. 4, 4a

NOTE: If using the optional Mixing Valve, see sheet #M968808 for installation instructions.

1. Insert FIBER WASHER (4) into SUPPLY NUT (1) on CONTROL BOX (2).
2. Connect FLEXIBLE SUPPLY HOSE (3) to SUPPLY NUT (1) on CONTROL BOX (2). Tighten to make a water tight connection. Use two wrenches to tighten if necessary. **Fig. 4.**
3. Connect FLEXIBLE SUPPLY HOSE (3) directly to wall supply. Connection on FLEXIBLE SUPPLY HOSE (3) is 3/8" compression. Use adjustable wrench to tighten connection. Do not over tighten. **Fig. 4a.**

Note: FLEXIBLE SUPPLY HOSE (3) measures 20" from the bottom of the CONTROL BOX (2) base. If additional supply length is required, installer must purchase parts separately.

Important: If FLEXIBLE SUPPLY HOSE (3) is too long, loop to avoid kinking.

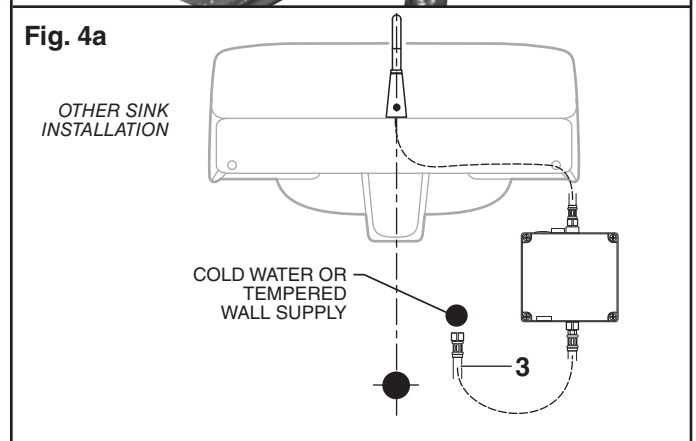
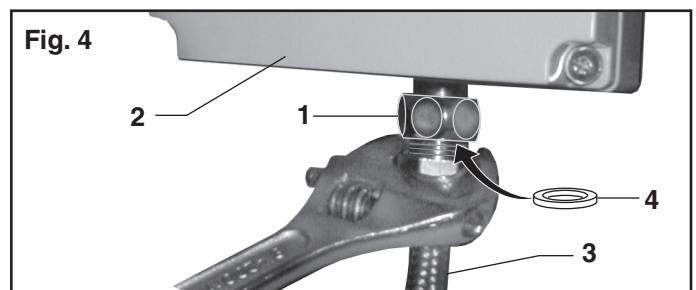
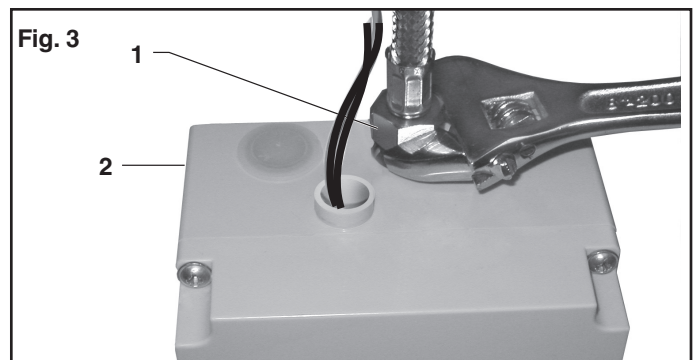
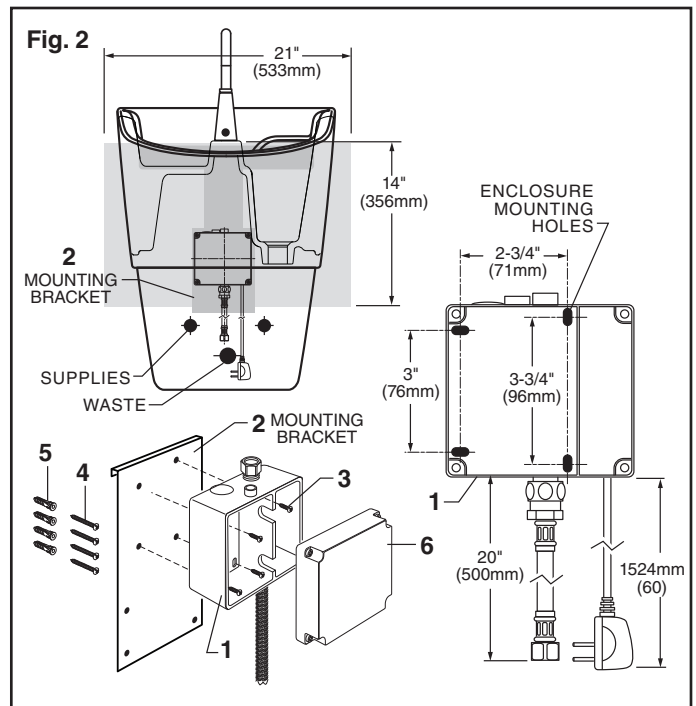

ELECTRICAL INSTALLATION

Product	Page
Plug-In AC Power Kit (PK00.PAC)	6
Hard-Wired AC Power Kit (PK00.HAC)	6
Multi-AC Power Kit (PK00.MAC)	7

A DC VERSIONS ; Fig. 1

- PWRX
- STANDARD BATTERY

1. Remove CONTROL BOX COVER (1). Fig. 1.
2. Feed the CABLES (2) through the top of CONTROL BOX (3). Fig. 1a.

FOR STANDARD BATTERY VERSION ONLY

3. Insert BATTERY (4) into BATTERY HOLDER (5), make sure the shape of the BATTERY (4) follows the shape of the BATTERY HOLDER (5) and terminal end is inserted first. Fig. 1b.

4. Insert the BATTERY CONNECTOR (5a) from the Standard Battery or PWRX BATTERY PACK through side GROMMET (6) as shown. Fig. 1c.
5. Connect SOLENOID CABLE (7) and BATTERY CONNECTOR (5a) to CABLES (2). Place Standard Battery or PWRX BATTERY PACK into housing. Fig. 1d.
6. Reinstall CONTROL BOX COVER (1). Tighten cover screws firmly.

CAUTION: Use only American Standard supplied cable sets. Using non-AS supplied cables, or cutting, splicing or modifying any components will void the warranty.

Fig. 1

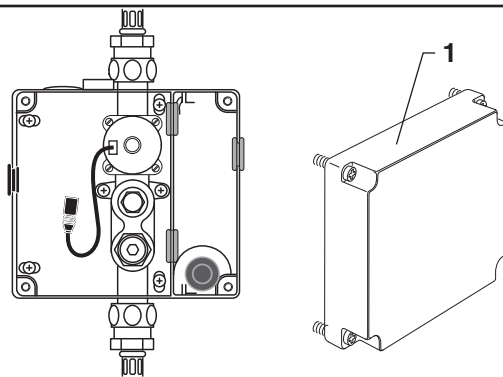

Fig. 1a

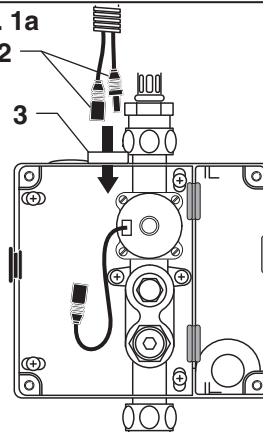

Fig. 1b

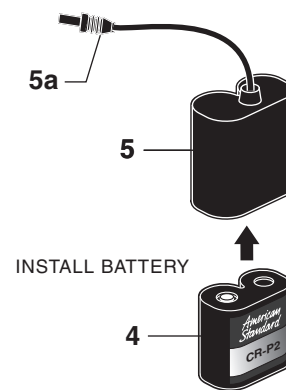

Fig. 1c

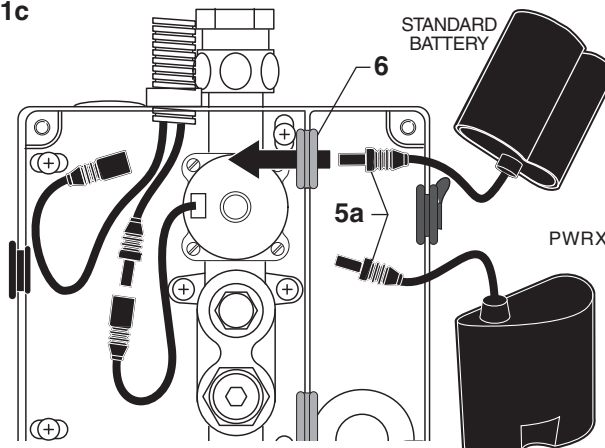
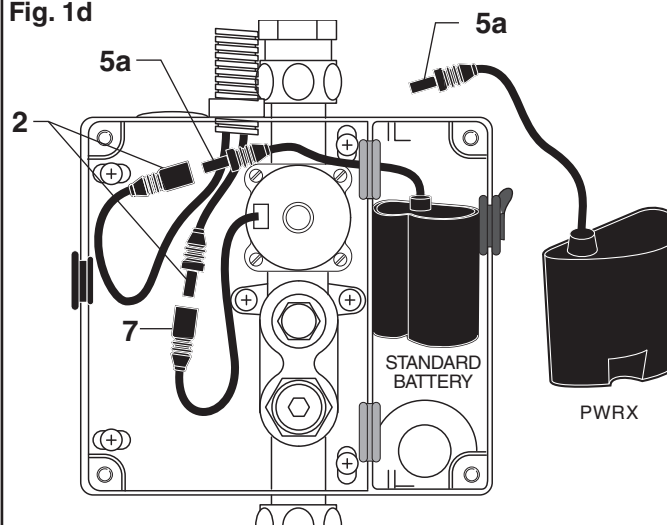

Fig. 1d



B AC VERSION; Fig. 2

- PLUG-IN
- HARDWARE

CAUTION Disconnect AC power supply before opening CONTROL BOX.

Note: For AC installation, make power supply connection before mounting CONTROL BOX (3) to wall.

1. Remove CONTROL BOX COVER (1). Feed the EXTENSION CABLES (2) from the Faucet through the top of ENCLOSURE (3).

FOR AC PLUG-IN ONLY

- 2a. Insert POWER CORD (8) through POWER SUPPLY GROMMET (9). Fig. 2a.
- 3a. Insert POWER CORD (8) through side GROMMET (6) as shown. Fig. 2a.
- 4a. Connect one of the CABLES (2) to SOLENOID CABLE (7) and the other to the SINGLE AC ADAPTER (10). Connect POWER CORD (8) to Single AC Adapter (10) and install CONNECTOR LOCKING DEVICE (16). Fig. 2a.
- 5a. Mount CONTROL BOX to wall. Replace CONTROL BOX COVER (1). Tighten cover screws firmly.
- 6a. Plug AC POWER SUPPLY into wall outlet.

FOR HARDWIRE HOOK-UP ONLY

- 2b. Insert one end of the 10' EXTENSION (10a) through POWER SUPPLY GROMMET (9). Fig. 2b.
- 3b. Insert 10' EXTENSION (10a) through side GROMMET (6) as shown. Fig. 2b.
- 4b. Connect CABLES (2) to SOLENOID CABLE (7) and the other to the 10' EXTENSION CABLE (10a). Install CONNECTOR LOCKING DEVICE (16). Fig. 2b.

Contractor to supply ELECTRICAL BOX (12) and power to POWER SUPPLY (13).

- 5b. Mount POWER SUPPLY (13) onto ELECTRICAL BOX (12). Connect connections to POWER SUPPLY CONNECTIONS (14). Fig. 2c.
- 6b. Connect the 10' EXTENSION (10b) to the POWER SUPPLY CABLE (15). Fig. 2c.

CAUTION: Use only American Standard supplied cable sets. Using non-AS supplied cables, or cutting, splicing or modifying any components will void the warranty.

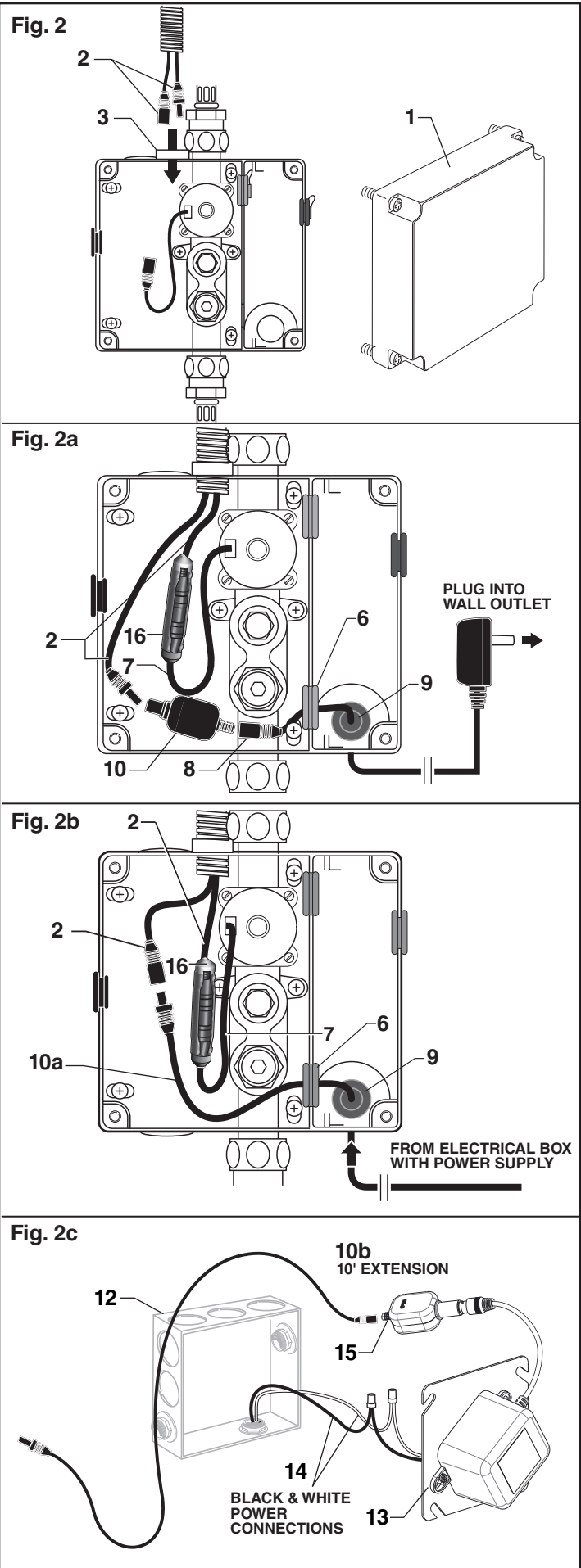

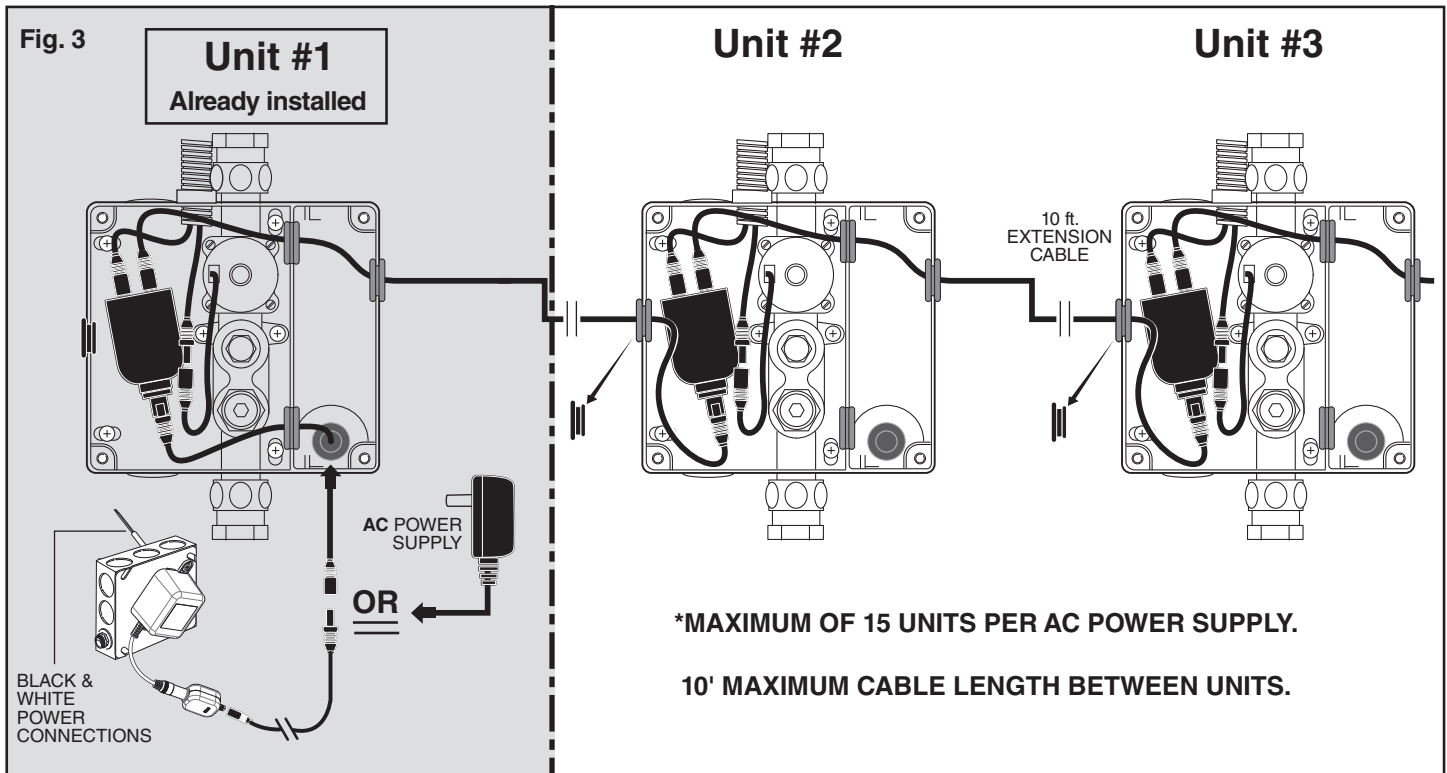

C MULTI-AC VERSION (DAISY-CHAIN); Fig. 3, 3a

Important: All control box covers must be removed before beginning to make daisy-chain connections.
Disconnect the first unit's Y-Adapter from power supply before making daisy-chain connections.

Note: For Unit #1 electrical instructions, refer to section B (page 6).
For subsequent Units, refer to instructions below...

1. Remove COVERS from all CONTROL BOXES (3).
2. Remove solid black plug grommet from left side of all CONTROL BOXES (3), and replace with GRAY GROMMET (5b). (Supplied with each Faucet).
3. Insert previous unit's 10' EXTENSION (11a) through gray GROMMET (5b) and connect to single terminal of Y-ADAPTER (11).
4. Feed CABLES (2) through the top of CONTROL BOX (3). Connect one CABLE (2) to the SOLENOID CABLE (7), and the other to either of the two available terminals of the Y-ADAPTER (11). Connect the current unit's 10' EXTENSION (10a) to available terminal of the Y-ADAPTER (11).
5. Feed the other end of the 10 ft.EXTENSION (10b) through the two GRAY GROMMETS (6a and 6b) and connect to the single terminal of the next unit's Y-ADAPTER (11). Place Y-ADAPTER (11) into CONTROL BOX (3).
6. Repeat Steps above for each additional Unit, for a Max. of 15 Units on one AC POWER SUPPLY.
7. Reinstall CONTROL BOX COVERS. Tighten cover screws firmly.

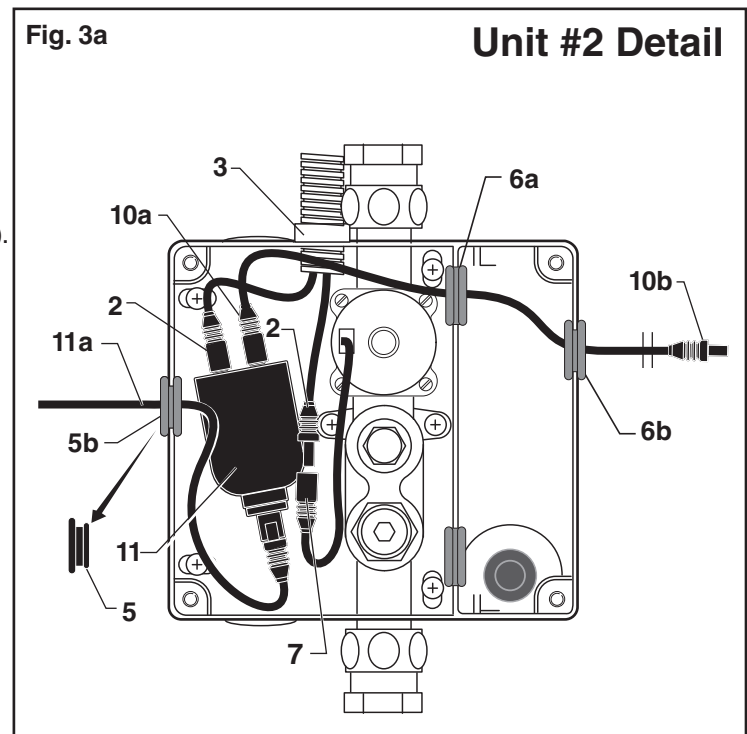

CAUTION: Use only American Standard supplied transformers and cable sets. Using non-AS supplied cables, or cutting, splicing or modifying any components will void the warranty.

TEST INSTALLED FAUCET

TO ENSURE A LAMINAR WATER FLOW, the air must be slowly purged from the spout. To do so, cover the **SENSOR (1)** while slowly opening the water supply valves. When the water flows as a solid, smooth, steady stream, uncover the **SENSOR (1)** and fully open the water supply valve. **Fig. 1.**

MAINTENANCE

A HAND WASH SENSOR OPERATION; Fig. 1

When the Sensor detects a user, the water immediately starts to flow. Water flow will stop 2 seconds after user is out of sensor range. The off delay allows the user to comfortably move his hands without the flow cycling on and off. As a precaution, a safety timer will turn off the water after the sensor has been blocked for 59 seconds. The water will stay off until the blockage is removed from the detection zone.

Detection Zone: 2" - 10" (50mm - 250mm)
Default: Set at Factory 6" (150mm)

B CHANGE SENSOR RANGE; (Factory set at 6") Fig. 2, 2a

1. Remove **CONTROL BOX COVER**. Disconnect Power Supply **(1)**, then reconnect. **Fig. 2.**
2. While the **SENSOR CONTROL LED (2)** is blinking slowly, place your hand 1 - 2 in. (30-50mm) in front of the sensor. **Fig. 2a.**
3. When the LED stops blinking and stays "ON", move your hand to the desired position and hold in place until the LED begins to blink again. **Fig. 2a.**
4. Once the **SENSOR CONTROL LED (2)** begins to blink again, remove your hand from the detection zone. When the flashing stops, the detection distance is set.
5. Reinstall **CONTROL BOX COVERS (2)**. Tighten cover screws firmly.

C CLEAN FILTER ASSEMBLY; Fig. 3

CAUTION Before opening **CONTROL BOX** disconnect AC power supply.

1. Remove **CONTROL BOX COVER**.
 2. Close **SUPPLY STOP (13)** with 4mm Hex wrench.
- Note: Activate sensor to keep water flowing out of faucet while shutting off.**
3. Unthread **FILTER ASSEMBLY (6)** using a 7/16" socket.
 4. Pull out the **FILTER ASSEMBLY (6)**, remove and clean white debris cup and filter screen.
 5. Install the **FILTER ASSEMBLY (6)** back in its place and tighten with a 7/16" socket.

Caution: Do not over tighten.

6. Open **SUPPLY STOP (13)** with 4mm Hex wrench.
7. Reinstall **CONTROL BOX COVER**. Tighten cover screws firmly.

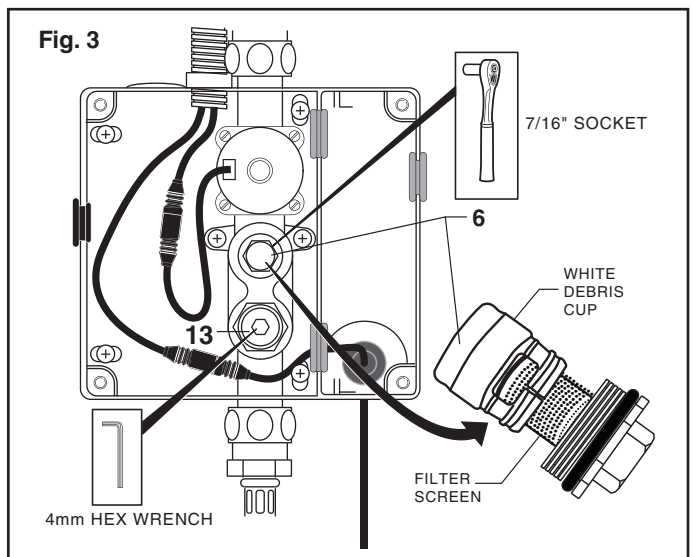
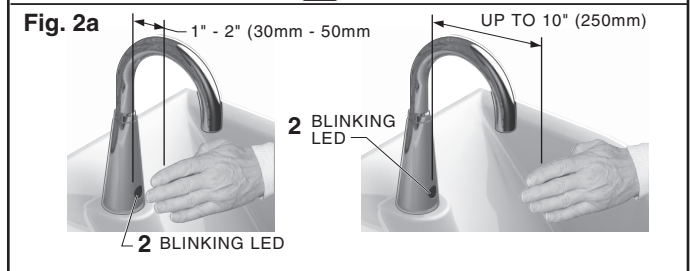
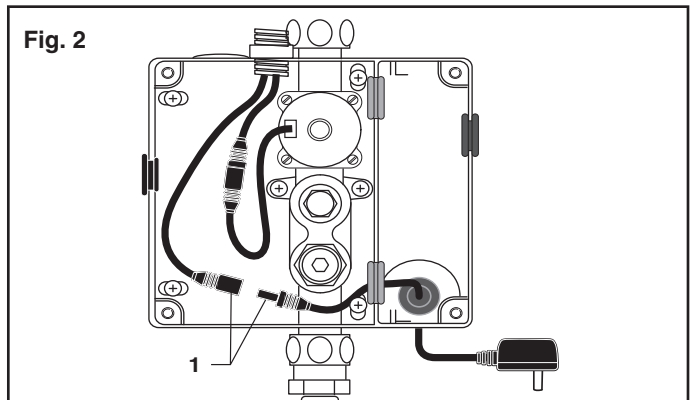
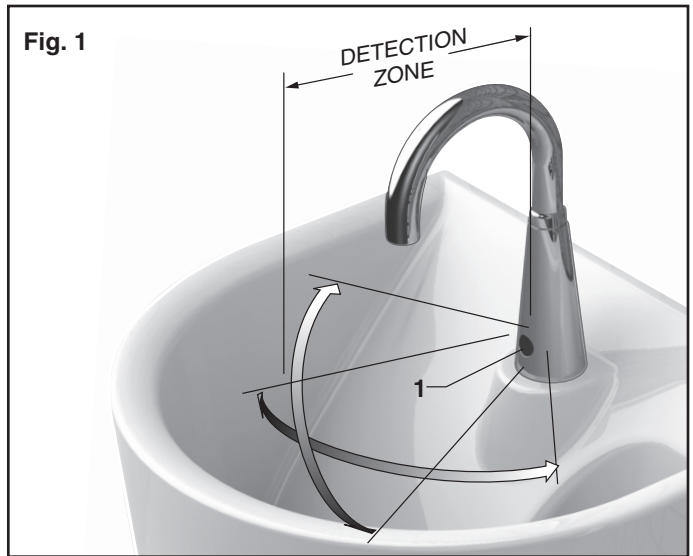

D INSTALL / REPLACE THE BATTERY or PWRX BATTERY PACK; Fig. 4

1. Remove CONTROL BOX COVER (1).
2. Disconnect Battery Holder (3) from CABLE (5).
3. Remove old BATTERY from Battery Holder (3). Install new BATTERY (2) making sure the terminal side is inserted first and shape of the battery follows the shape of the BATTERY HOLDER (3).
4. Reconnect BATTERY HOLDER (3) to CABLE (5).
5. To replace PWRX BATTERY PACK (4), unplug and replace with new Power Pack.
6. Reinstall CONTROL BOX COVER. Tighten cover screws firmly.

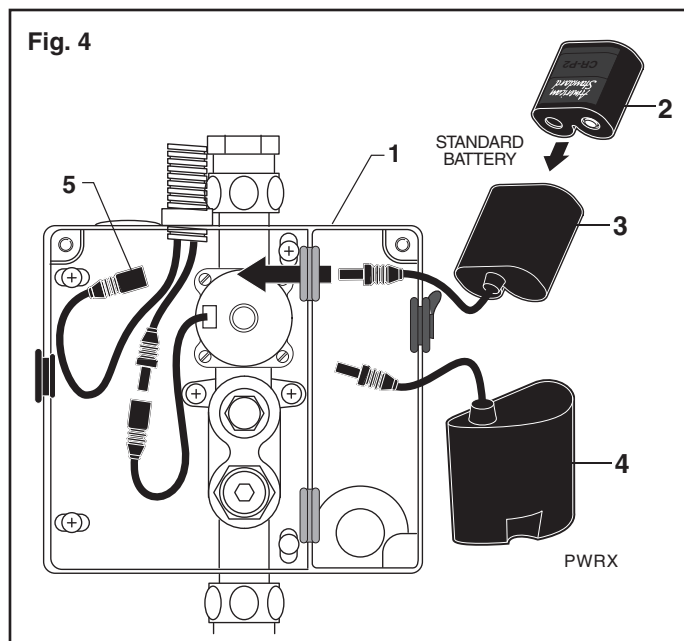

E CLEAN AND REMOVE FLOW RESTRICTOR; Fig. 5

1. Remove SET SCREW (1) with FLAT BLADE SCREWDRIVER (2). Pull off SPOUT (3) from faucet base. Fig. 5.
2. Remove HOUSING (4) and remove FLOW RESTRICTOR (5). Fig. 5a.
3. Clean FLOW RESTRICTOR (5). Reassemble and install into SPOUT BASE (6). Reassemble SPOUT (3) onto SPOUT BASE (6) and tighten SET SCREW (1). Fig. 5.

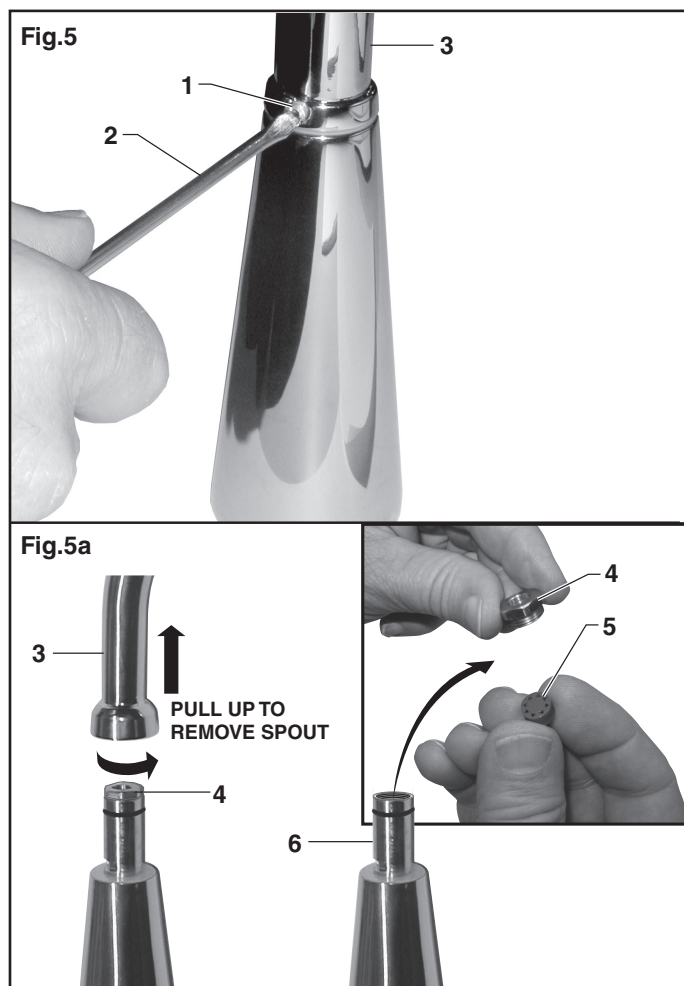

F GENERAL CLEANING; Fig. 5

1. Only use a damp, soft cloth to clean the spout and the sensor.
2. For tougher dirt, use a soft cloth with diluted dish washing detergent. Wipe the area using a wet cloth.

CAUTION Do not scratch the sensor when cleaning. Avoid using any abrasives or harsh detergents or chemicals.

Fig.6



FAQ'S

Q: How will I know if the battery needs to be replaced?

A: Valve will not open and sensor will continuously blink 2 times interrupted by a pause, for up to 7 days.

Q: Why has the flow rate of the faucet reduced significantly?

A: The filter assembly, flow regulator or areator/spray may be clogged. Check and clean. Refer to Start-up/ Maintenance, sections C, D and E.

Q: Why doesn't water flow out of faucet when I'm within the sensor detection zone?

A: Battery may need replacement. If sensor continuously blinks 2 times interrupted by pause, replace battery or call (844) CRT-TEAM / (844) 278-8326.Z

Q: What is the normal operating pressure range?

A: Faucet will operate with supply pressures ranging from 20-80 psi.

TROUBLESHOOTING FLOW CHARTS

UNIT DOES NOT FUNCTION

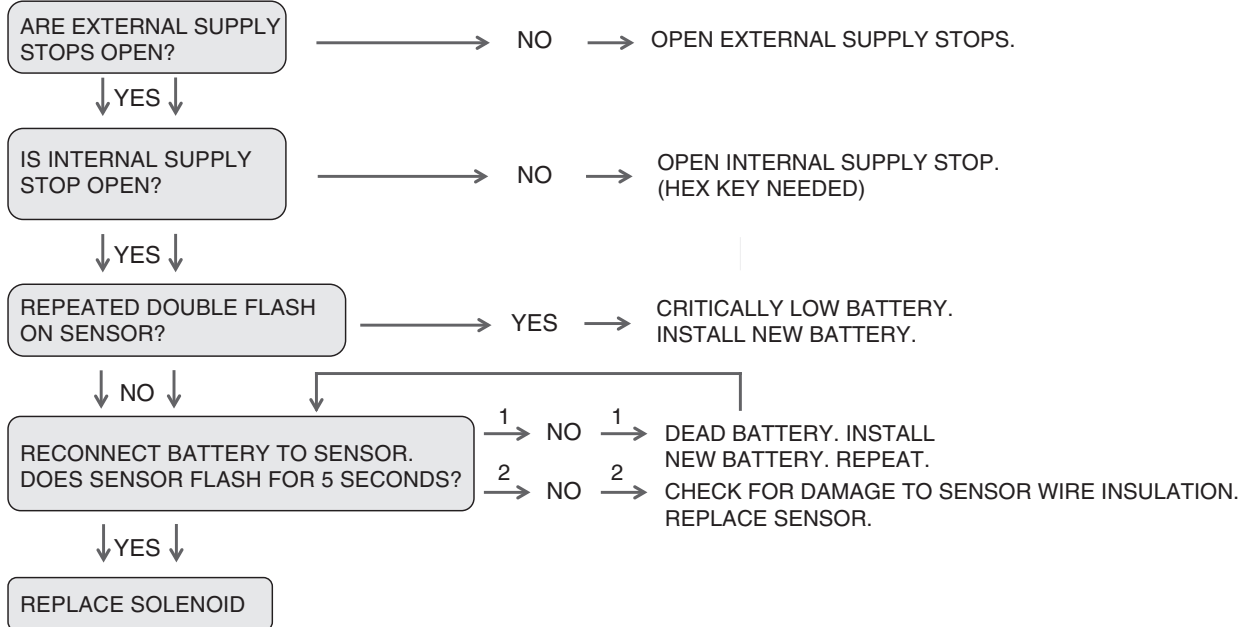

WATER IS CONTINUOUSLY RUNNING

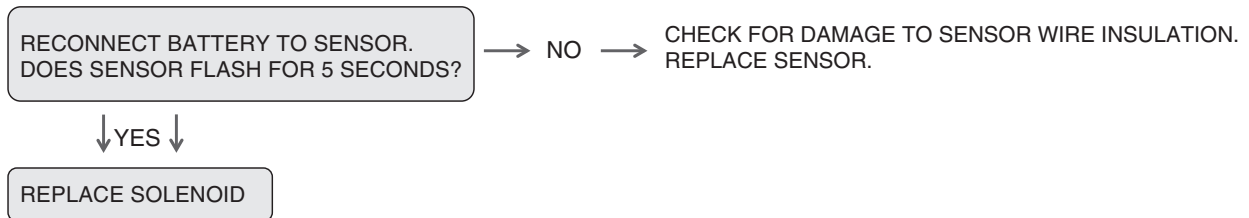

LOW FLOW ISSUES

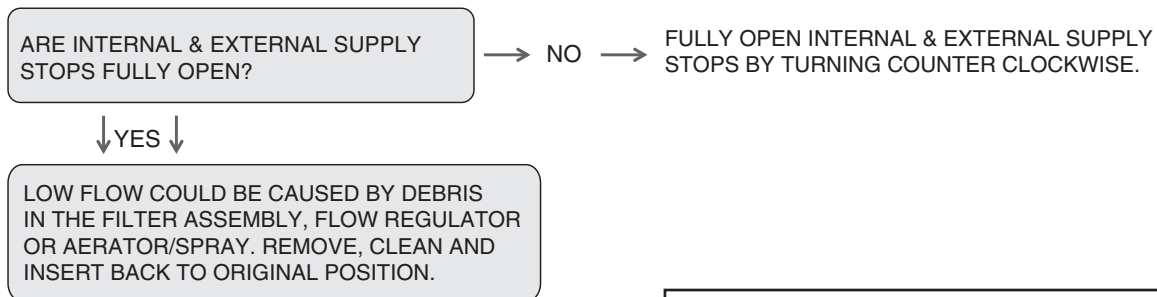

HOT LINE FOR HELP
For toll-free information and answers to your questions, call:
(844) CRT-TEAM / (844) 278-8326
Mon. - Fri. 8:00 a.m. to 8:00 p.m. EST Saturday 10:00 a.m. to 4:00 p.m. EST
IN MEXICO 01-800-839-1200
IN CANADA 1-800-387-0369 (TORONTO 1-905-306-1093)
Weekdays 8:00 a.m. to 7:00 p.m. EST

Product names listed herein are trademarks of AS America, Inc. ©2019

To learn more about American Standard Selectronic® Products visit our website at:
www.americanstandard-us.com or e-mail us at: CRTTEAM@lixilamericas.com