

WALK-IN BATH 3260.219 LUXURY SERIES



American Standard

The American Standard 32" x 60" Acrylic walk-in bath provides the maximum in therapeutic soaking pleasure with the largest water capacity in our product line. The full sized, contoured door with a low door threshold allows ease of entry and exit.

Fully equipped, the 219 Luxury Series offers all the latest in safety and comfort features with the most advanced therapeutic options and backed by a lifetime warranty on the door seal, a 15 year warranty on the tub shell and a 10 year warranty on all other components.

Whirlpool Massage



A soothing and invigorating water jet massage system, the Whirlpool massage features an in-line heater, an automatic tub cleaning system and Legs-Only massage. Customize back and leg muscle therapies with 13 different water jets. The Whirlpool Spa is combined with all of the features of the Soaker Tub providing an enhanced therapeutic bathing experience.

Air Spa Massage



Experience a soft and caressing all-over body massage powered by a variable speed heated blower that releases thousands of air bubbles rising throughout the water from 26 different air jets. The automatic purge cycle helps keep the system running efficient and clean. The Air Spa is combined with all of the features of the Soaker Tub providing an enhanced therapeutic bathing experience.

Combination System



Combines all of the features of the Soaker Tub, the Whirlpool Massage and the Air Spa Systems, plus a multi-colored Chromatherapy light system for the ultimate therapeutic bathing experience.

Quick Drain® System



Spend less time waiting with this patented innovation, that requires no additional plumbing, once activated it rapidly pumps the water out from within the tub-making it safe to open the door and exit the tub. Included in all systems.

3260.219 LUXURY SERIES 32" X 60" WALK-IN BATH

3260.219.SXX Soaking Tub

- Available in White or Linen and in Left Hand or Right Hand Door/Drain Configuration
- Patented watertight door system with a lifetime warranty on the door seal
- Built-in chair height seat
- Color matched trim and cable driven waste and overflow
- Built-in safety bar and textured tub floor
- Cushioned neck rest
- Patented Quick Drain® fast water removal system
- Premium fast-fill tub faucet and handheld showering wand

3260.219.WXX Whirlpool Massage System

Combines all of the features of the Soaking Tub, plus:

- 13 massage jets with variable flow
- Legs-only massage
- Whirlpool in-line heater
- Self-cleaning sanitation system

3260.219.AXX Air Spa System

Combines all of the features of the Soaking Tub, plus:

- 26 seat and floor air injectors
- Variable speed heated blower
- Automatic purge cycle

3260.219.CXX Combination System

Combines all of the features of the Soaker Tub, the Whirlpool Massage and the Air Spa Systems for the ultimate therapeutic bathing experience, plus:

- Multi-colored Chromatherapy light system positioned at the bottom of the bath that creates a peaceful bathing experience

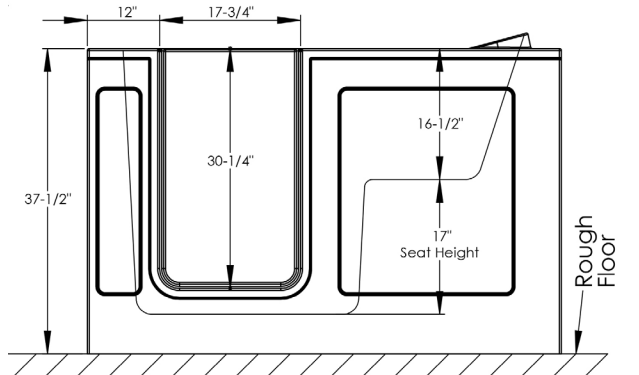
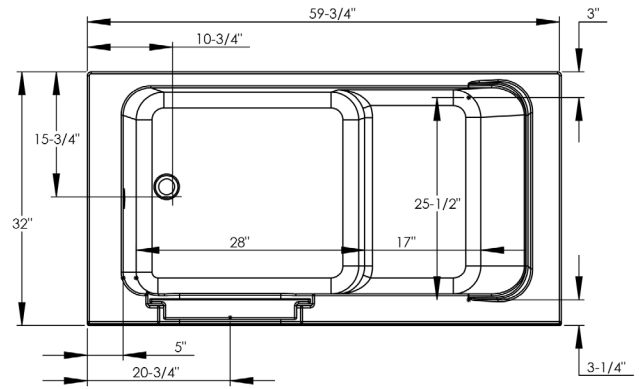

GENERAL SPECIFICATIONS FOR 3260.219.XXX WALK-IN BATHTUB

INSTALLED SIZE _____ 60 x 32 x 37 In. (1524 x 813 x 940mm)
 WEIGHT _____ 234 Lbs. (106 Kg.)
 WEIGHT w/WATER _____ 900 Lbs. (408 Kg.)
 OPERATING GALLON _____ 80 Gal. (303 L.)
 FLOOR LOADING _____ 58 Lbs./Sq. Ft. (240.25 Kgs/Sq. m.)
 (PROJECTED AREA)
 CUBE (FT³) _____ 41.1

To Be Specified - Required:

- Drain Configuration: Left (L) or Right (R)
- Color: White (W) or Linen (L)

Options:

- Handshower Glide Bar: 9HSB
- 24 inch Grab Bar: 9GB-24
- End Panel for Seat Side
- End Panel for Faucet Side
- End Panel for Backside



**Designed
for pain relief
& easy use**

Notes: The whirlpool heater is designed to maintain water temperature during operation. It will not heat cold water to desired bathing temperature. Tub is supported by the frame and five integrated adjustable feet, no additional support required. Refer to installation instructions supplied with tub for additional information. Provide suitable reinforcement to sub floor for all supports.

Our products are in compliance with the following codes: Uniform Plumbing Code UPC®; National Plumbing Code of Canada; International Plumbing Code IPC®

Our products conform to the following standards: ASME A112.19.7, ASME A112.19.15; CSA B45, CSA B45.5; CSA C22.2 No. 218.2; UL-1795; ANSI Z124.1.2

Our products are listed with: c ETL us

IMPORTANT: Dimensions of fixtures are nominal, may vary and are subject to change or cancellation. No responsibility is assumed for use of superseded or voided leaflet.

American Standard