

## SELECTRONIC™ PROXIMITY TOILET FLUSH VALVE 1.28 & 1.6 GPF



MODEL NUMBERS	
6065.161	6065.162
6065.121	6065.122
6065.565	6065.525

**Exposed Flushometer  
for 1-1/2" Top Spud Bowls**

**CLOG RESISTANT**

- Self-cleaning piston valve prevents clogging and reduces maintenance.

**ONE SENSOR FITS ALL**

- Only 1 sensor for entire Selectronic™ line of faucets, urinals, and flush valves.
- Range can be adjusted manually or with optional remote control.
- Sensor Features Low Battery Indicator.

Certified to comply with ASME A112.19.2M  
© 2008 AS America, Inc.

M968699 Rev.1.6

*American Standard*

**NOTE TO INSTALLER: Please give this manual to the customer after installation.**

To learn more about American Standard Faucets visit our website at: [www.americanstandard-us.com](http://www.americanstandard-us.com)  
or U.S. customer's e-mail us at: [faucetsupport@americanstandard.com](mailto:faucetsupport@americanstandard.com)

**For Parts, Service, Warranty or other Assistance,**  
please call **1-800-442-1902 (In Canada: 1-800-387-0369)**  
(In Toronto Area only: 1-905-3061093)

Thank you for selecting American-Standard...the benchmark of fine quality for over 100 years. To ensure that your installation proceeds smoothly--please read these instructions carefully before you begin.

## UNPACKING

All American Standard Products Are Water Tested At Our Factory. Some Residual Water May Remain In The Valve During Shipping.

1. Remove the Flush Valve items from the carton. The illustration below shows all items after they have been removed from the carton. Some items may be packaged partially assembled to other items.

- |                                  |                              |
|----------------------------------|------------------------------|
| 1. Flush Valve Assembly          | 5. Sweat Solder Adapter      |
| 2. Down Tube and Vacuum Breaker  | 6. Cover Tube                |
| 3. Spud Coupling Nut and Washers | 7. Wall Escutcheon           |
| 4. Spud Flange                   | 8. Supply Stop               |
|                                  | 9. Installation Instructions |

### CARE INSTRUCTIONS:

**DO: SIMPLY RINSE THE PRODUCT CLEAN WITH CLEAR WATER. DRY WITH A SOFT COTTON FLANNEL CLOTH.**

**DO NOT: DO NOT CLEAN THE PRODUCT WITH SOAPS, ACID, POLISH, ABRASIVES, HARSH CLEANERS, OR A CLOTH WITH A COARSE SURFACE.**

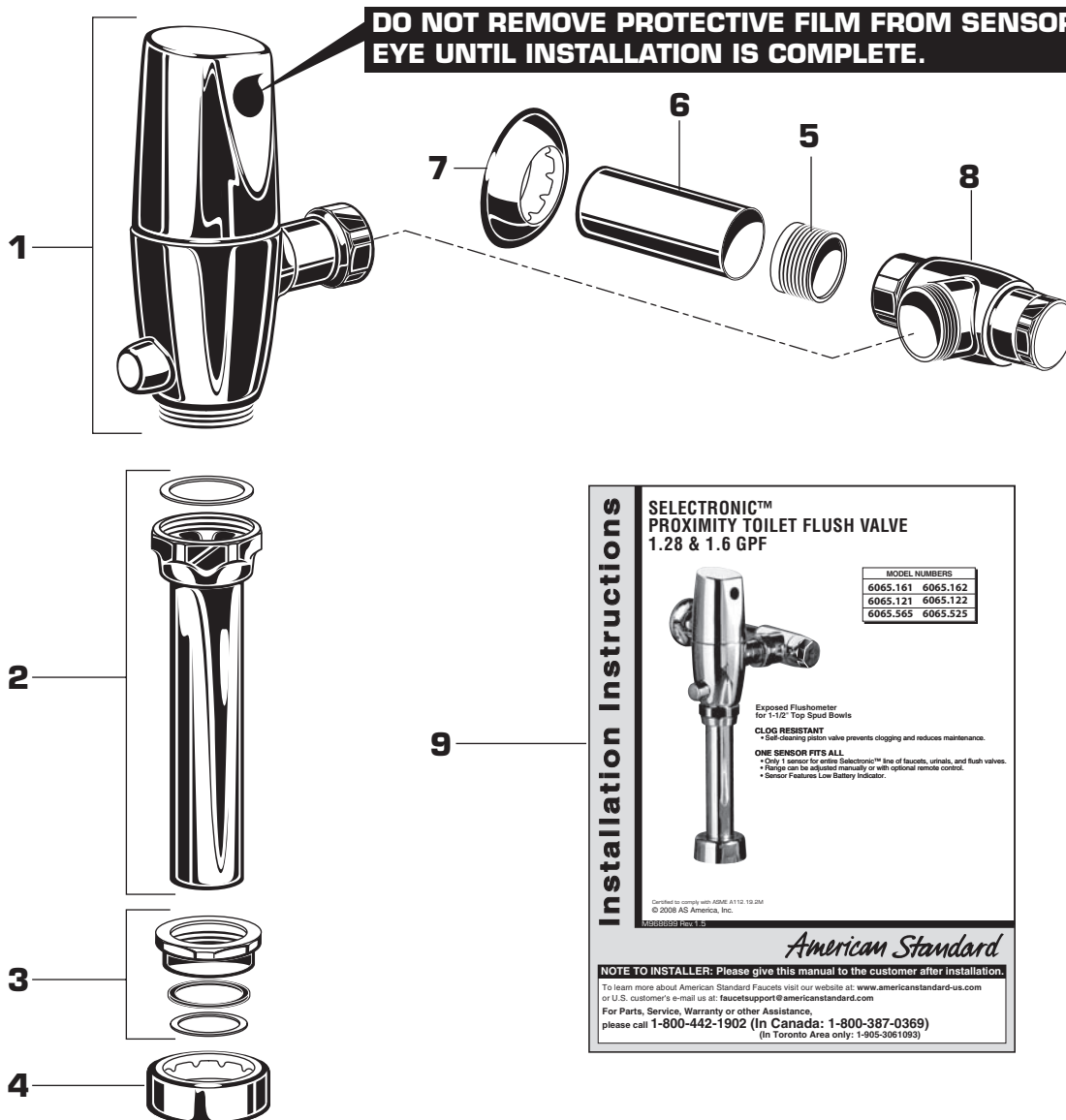

**Installation Instructions**

**SELECTRONIC™ PROXIMITY TOILET FLUSH VALVE**  
1.28 & 1.6 GPF

MODEL NUMBERS	
6065.161	6065.162
6065.121	6065.122
6065.565	6065.525

Exposed Flushometer for 1-1/2" Top Spud Bolts

**CLOG RESISTANT**  
• Self-cleaning piston valve prevents clogging and reduces maintenance.

**ONE SENSOR FITS ALL**  
• Only 1 sensor for entire Selectronic™ line of faucets, urinals, and flush valves.  
• Range can be adjusted manually or with optional remote control.  
• Sensor Features Low Battery Indicator.

Certified to comply with ASME A112.19.2M  
© 2008 AS America, Inc.  
M968699 Rev. 1.6

American Standard

**NOTE TO INSTALLER: Please give this manual to the customer after installation.**  
To learn more about American Standard Faucets visit our website at: [www.americanstandard-us.com](http://www.americanstandard-us.com)  
or U.S. customer's e-mail us at: [faucetsupport@americanstandard.com](mailto:faucetsupport@americanstandard.com)  
For Parts, Service, Warranty or other Assistance, please call 1-800-442-1902 (In Canada: 1-800-387-0369)  
(In Toronto Area only: 1-905-3061093)

**Fig. 1**  
**Roughing-in Dimensions**

**GENERAL DESCRIPTION:**

**SELECTRONIC™  
PROXIMITY TOILET  
FLUSH VALVE**

**Exposed Flushometer  
for 1-1/2" Top Spud Fixtures**

Exclusive, self cleaning piston-type flush valve with proximity operation and manual override. Operates on DC (battery) power. Recommended operating pressure 35 to 80 psi. Can install left or right-handed. Detection Zone can also be adjusted manually, or with optional remote control.

**Right or Left Hand Installation**

See (Section 5) for converting Flush Valve to Left Hand Installation.

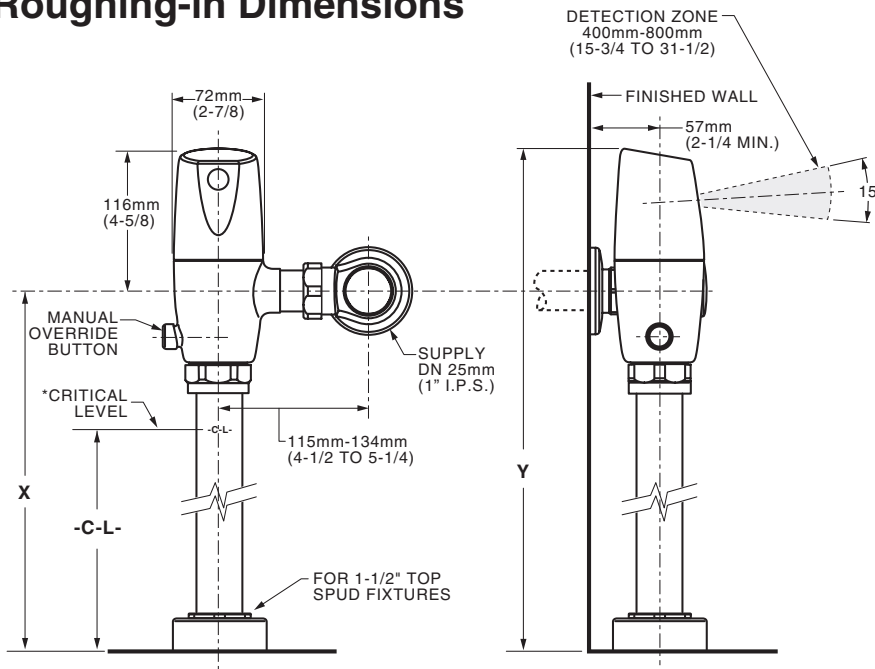
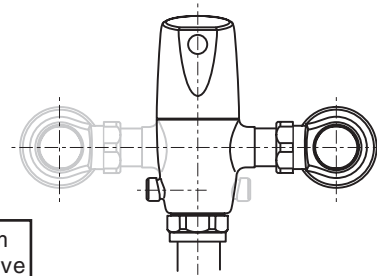

MODEL	X	Y	-C-L-
6065.121 6065.161	293mm (11-1/2)	409mm (16-1/8)	165mm (6-1/2)
6065.122 6065.162	683mm (27)	799mm (31-1/2)	565mm (22-1/4)

\*Note: The Critical Line (-C-L-) on Vacuum Breaker must typically be 6" (152mm) above fixture. Consult Codes for details.

**RECOMMENDED TOOLS; Fig. 2**

1. Teflon Tape
2. Flat Blade Screwdriver
3. Adjustable Wrench
4. Tape Measure
5. Hacksaw
6. Tubing Cutter
7. File
8. For Sweat Connection; Solder and Torch
9. 2.5mm Hex Wrench
10. 1.5mm Hex Wrench

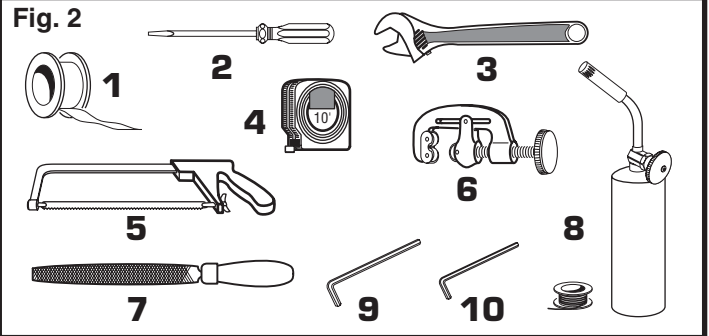

**PRIOR TO INSTALLATION**

**Note:** Prior to installing the Selectronic™ Flush Valve the following items must be installed.

1. Water Closet
2. Drain line
3. Water supply line

**IMPORTANT:**

- All plumbing must be installed in accordance with applicable codes and regulations.
- Water supply lines must be sized to provide an adequate volume of water for each fixture.

- Flush all water lines prior to operation (See Step 4). Dirt and debris can cause flush valve to run continuously.
- With the exception of Supply Stop Inlet, DO NOT use pipe sealant or plumbing grease on any valve component or coupling!
- Protect the chrome or special finish on the Flushometer. DO NOT USE toothed tools on finished surfaces to install or service these valves. Also see "Care and Cleaning" section of this manual.
- This product contains mechanical and/or electrical components that are subject to normal wear. These components should be checked on a regular basis and replaced as needed to maintain the valve's performance.

## 1 INSTALL THE SWEAT SOLDER ADAPTER; Fig. 3

**CAUTION** Turn water supplies off before beginning

**Note:** Install Optional Sweat Solder Adapter (Supplied) for copper pipe supply line. Fig. 3.

1. Measure the distance (A) from the finished wall to the center of the inlet spud on the fixture.
2. Cut the supply pipe 1-1/4" (A-B=C) shorter than the measurement taken in Step 1. File any rough edges off the end of the supply pipe.
3. Clean the end of the supply pipe. Push the threaded Adapter on until it is seated against the internal stop. Sweat the Adapter to the pipe.

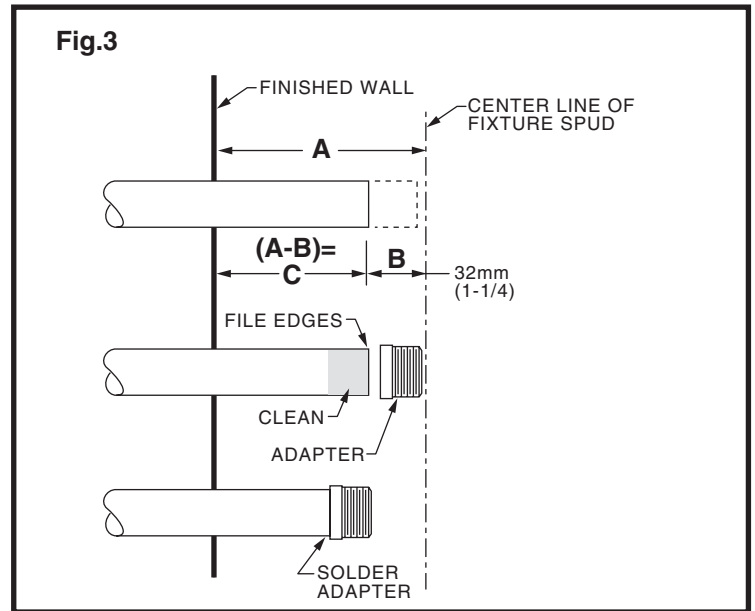

## 2 INSTALL COVER TUBE, WALL ESCUTCHEON and SUPPLY STOP; Fig. 4

1. Measure from finished wall to first thread of Adapter or threaded supply pipe (dimension "X"). Cut COVER TUBE (1) to length (X). Apply Teflon Tape to the threaded end of the Adapter or supply pipe. Fig. 4a.
2. Push the COVER TUBE (1) into the WALL ESCUTCHEON (2). Slide both onto the SUPPLY PIPE (3). Fig. 4b.
3. Push the COVER TUBE (1) in to expose the threads of the supply pipe. Fig. 4c. With a wrench thread the SUPPLY STOP (4) onto the SUPPLY PIPE (3). Align and tighten. Fig. 4c.
4. Pull COVER TUBE (1) against SUPPLY STOP (4) and push WALL ESCUTCHEON (2) against finished wall.

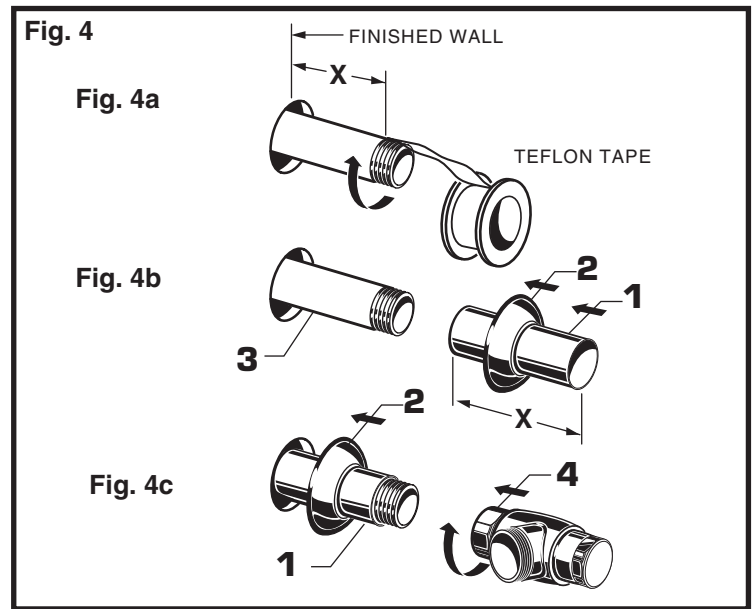

## 3 INSTALL DOWN TUBE AND VACUUM BREAKER; Fig. 5

1. Place the SPUD FLANGE (1) over the spud on the Fixture.
2. Thread SPUD COUPLING NUT (2) onto Spud. Make sure SEAL WASHER (3) and FRICTION WASHER (4) are installed. Do not tighten fully.
3. Insert the DOWN TUBE (5) into the SPUD COUPLING NUT (2) and push it down.

**Note:** If cutting Down Tube (5) to size, note that Critical Line (C/L) on Vacuum Breaker must typically be 6" (152mm) above fixture. Consult Code for details.

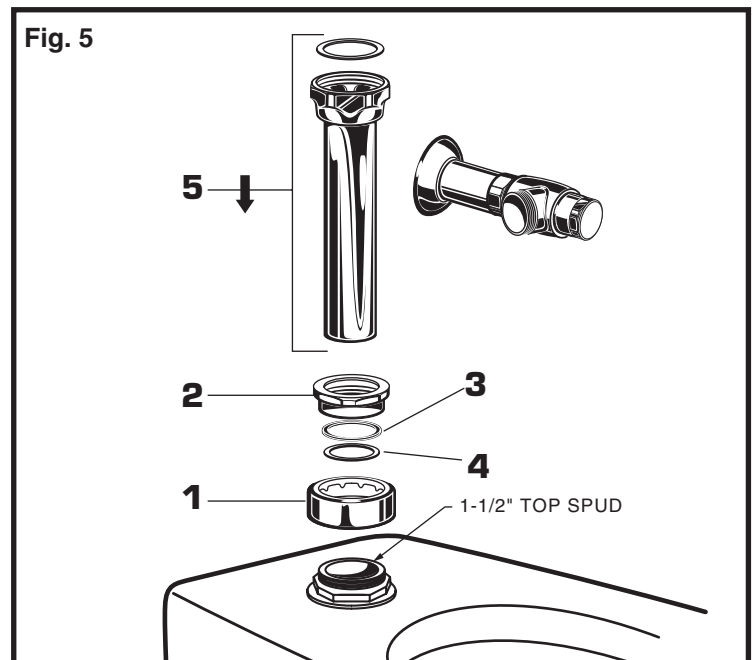

#### 4 FLUSH OUT SUPPLY LINES; Fig. 6

1. Remove COVER (1) from SUPPLY STOP (2).
2. With a flat blade screwdriver open SUPPLY STOP (2).
3. Turn on water supply to flush line of any debris or sediment.
4. Close SUPPLY STOP (2) and replace COVER (1).

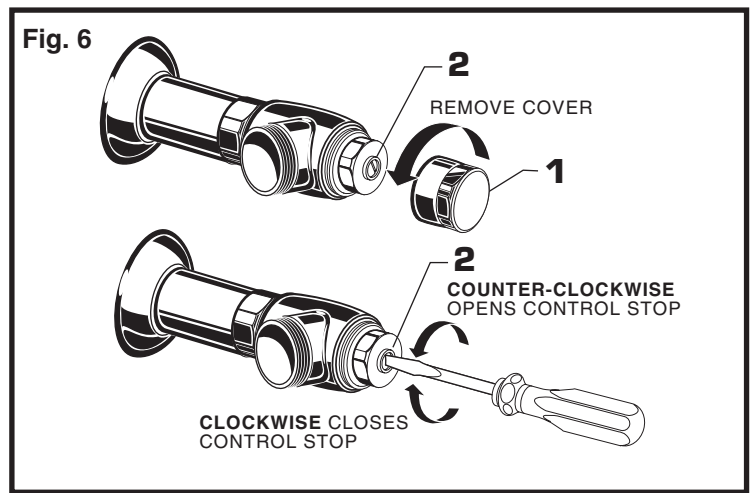

#### 5 LEFT OR RIGHT HAND INSTALLATION; Fig. 7

The UNIT is shipped with the inlet flange on the right side. If needed, the orientation can be reversed by following the steps below.

1. Loosen SET SCREW (1) with 2.5mm Hex Wrench (4) in back of top half of FLUSH VALVE (2). Fig. 7a.
2. Rotate TOP (2) to the right and pull off. Fig. 7b.
3. Rotate bottom half of FLUSH VALVE (3) 180°. Fig. 7b.
4. Replace TOP (2) and rotate until key engages then tighten SET SCREW (1). Fig. 7c, 7d.

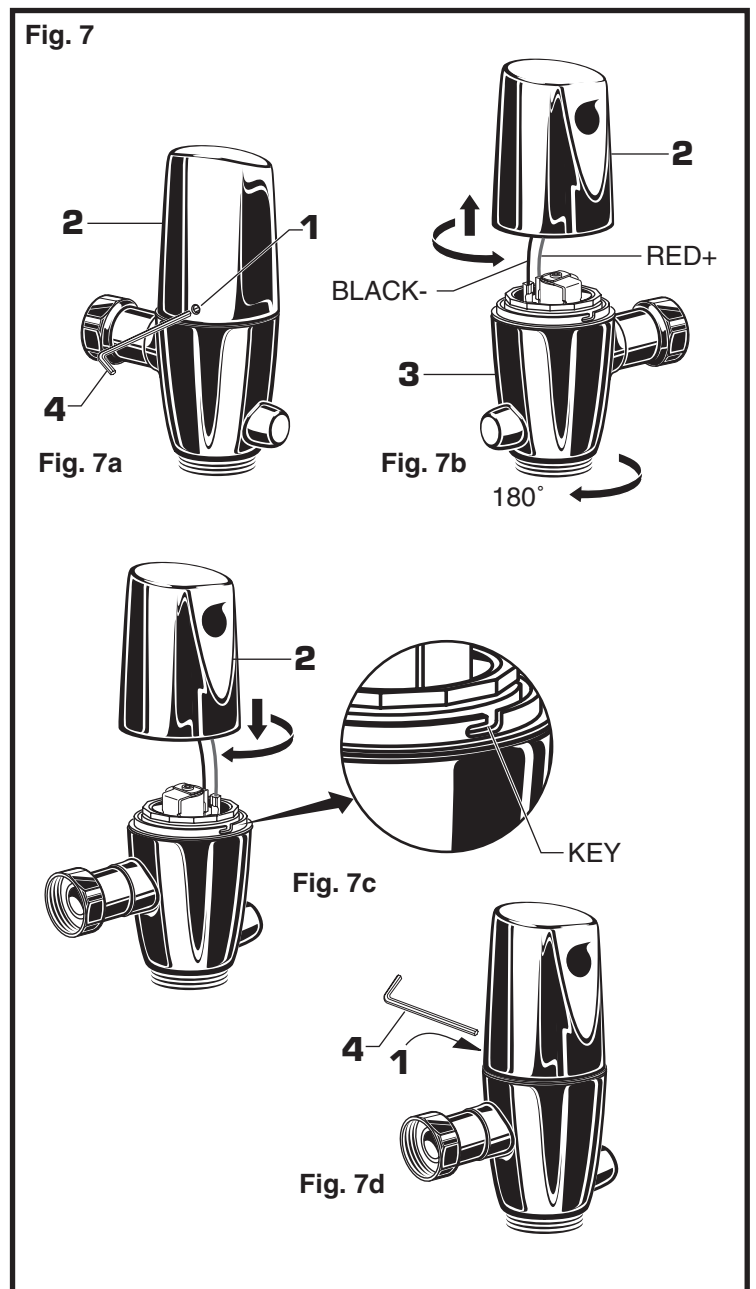

## 6 INSTALL FLUSH VALVE;

### Fig. 8a & 8b

1. As shown in **Fig. 8a**, insert the side INLET FLANGE (1) on the FLUSH VALVE (2) into the SUPPLY STOP (3). Lubricate the INLET FLANGE O-RING (4) with water if necessary. Lightly tighten COUPLING NUT (5). **Fig. 8a.** **Important: Do not use lubricants (other than water) or any type of thread sealing paste or tape.**

2. Align the FLUSH VALVE (2) (**Fig. 8b**) directly above the DOWN TUBE (7) and VACUUM BREAKER COUPLING NUT (6). Make sure that GASKET (10) is installed.

**Note: There is a +13mm, -6mm (+1/2, -1/4) tolerance for the 121mm (4-3/4) dimension. Fig. 8b.**

3. Pull the DOWN TUBE (7) up to meet the threaded FLUSH VALVE CONNECTION (8) and hand tighten the VACUUM BREAKER COUPLING NUT (6). Align all components of the flush valve assembly. **Fig. 8b.**

4. Lightly tighten the COUPLING NUT (5) connection first, then the VACUUM BREAKER COUPLING NUT (6) and finally the SPUD COUPLING NUT (9). Once aligned correctly, use a wrench to tighten couplings to make water tight connections. **Fig. 8b.**

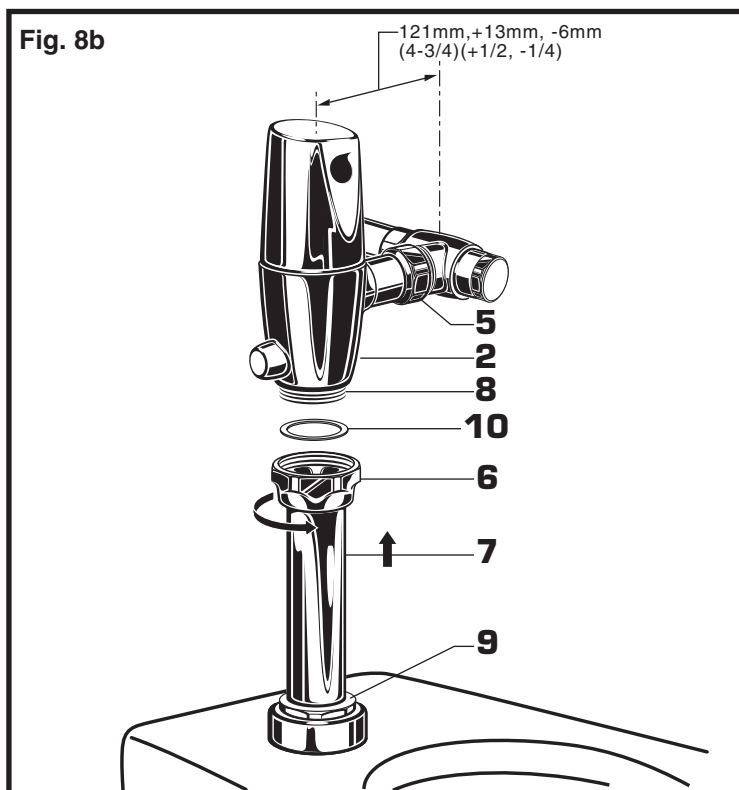
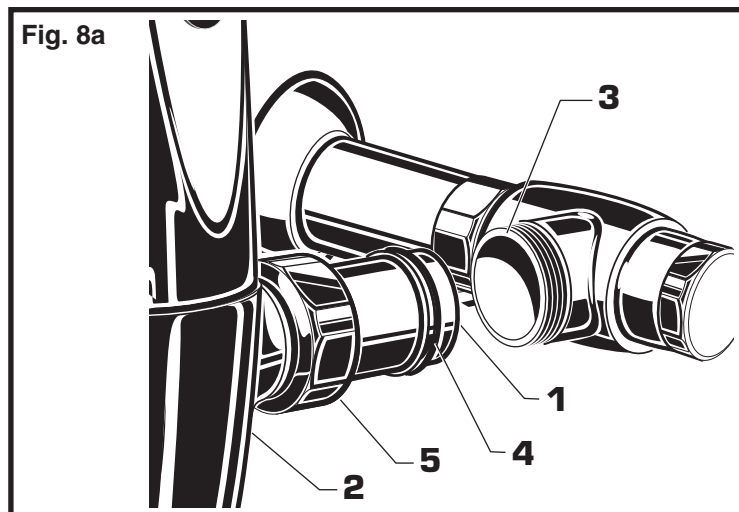

## 7 ADJUST SUPPLY STOP; Fig. 9

**IMPORTANT: To avoid overflowing, the SUPPLY STOP (3) must never be opened to the point where the flow from the valve exceeds the flow capacity of the fixture. The fixture must be able to handle a continuous flow in case of a flush valve failure.**

1. After installation is complete, peel off the PROTECTIVE FILM (1) from the sensor. Standing to one side, block the sensor with your hand for 10 seconds. **Remove your hand and listen for audible "click" from within the valve.**

2. Remove COVER (2) from SUPPLY STOP (3). Turn on water supply 1/4 turn to 1/2 turn (CCW) and test for leaks. **Note: Unit may flush for approximately 5 to 10 sec. when water is first turned on. If flow persists, turn water off and repeat step #1 above.**

3. Actuate the FLUSH VALVE:  
A) Cover sensor with hand for 10 seconds.  
**NOTE: Stand outside of sensor detection area.**  
B) Remove hand from in front of the sensor; unit will flush in approximately 3 seconds.

4. Adjust SUPPLY STOP (3) after each flush until the stated flush volume is achieved, no splashing occurs and the fixture is properly cleansed.

5. When adjustment is complete, replace COVER (2) and tighten to ensure vandal-resistance.

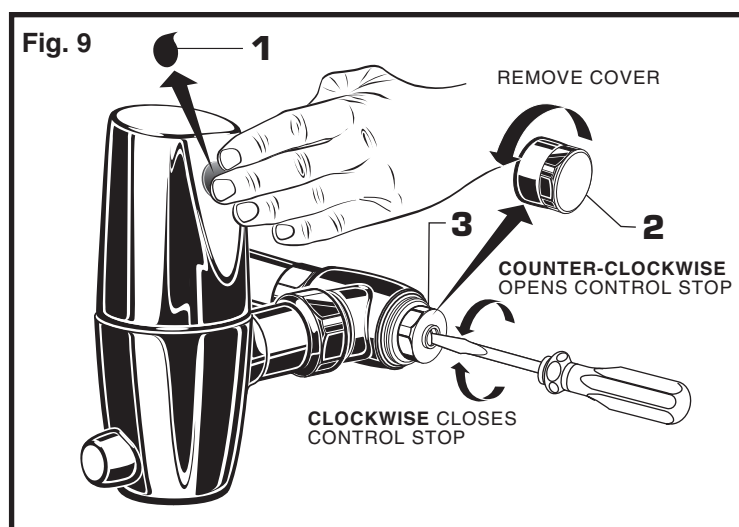

## 8 HOW TO RETROFIT OUR VALVE;

### Fig. 10

(Replaces Industry Standard Manual and Electronic Valves)

**Note:** In most Retrofits the wall escutcheon, supply stop, cover tube and vacuum breaker do not have to be replaced. If these items do need replacement they must be purchased separately or order the complete flush valve assembly from American Standard.

1. Remove COVER (1) from SUPPLY STOP (2) if installed. **Fig. 10.**

2. Turn water supply off. **Fig. 10.**

3. Loosen SPUD COUPLING NUT (3). Unthread COUPLING NUT (4) and VACUUM BREAKER COUPLING NUT (5). Remove FLUSH VALVE (6). **Fig. 10.**

4. Clean all threaded connections before installing the new flush valve. **Fig. 10a.**

5. Refer to **Sections 5,6 and 7** to complete the retrofit installation. **Fig. 10b.**

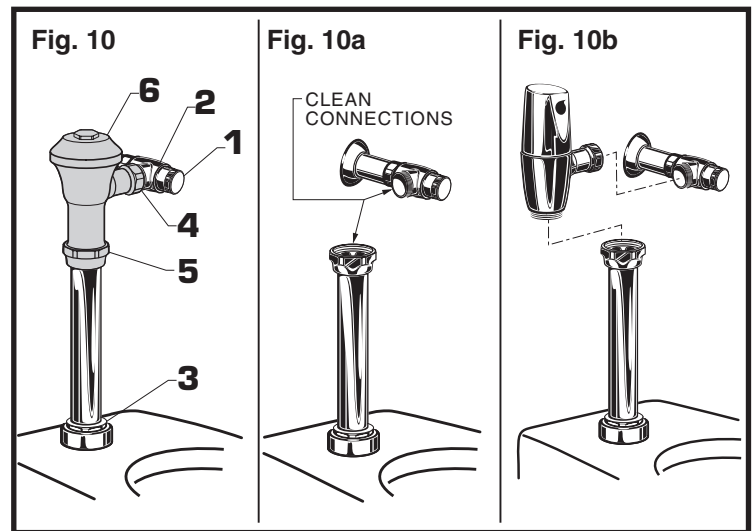

## 9 HOW TO CHANGE THE BATTERY;

### Fig. 12

1. Loosen SET SCREW (1) with 2.5mm Hex Wrench (2) in back of top half of FLUSH VALVE CAP (3). **Fig. 12a.**

2. Rotate CAP (3) to the right and pull off. **Fig. 12b.**

3. Turn CAP (3) over and remove the two SCREWS (4). Remove the BATTERY COVER (5) to expose the battery (6). Remove old BATTERY (6). **Fig. 12c.**

4. Install the new BATTERY (7) making sure the + & - are facing up towards the open end of the cover. **Fig. 12d.**

5. Replace the BATTERY COVER (5), reverse the above steps to assembly flush valve.

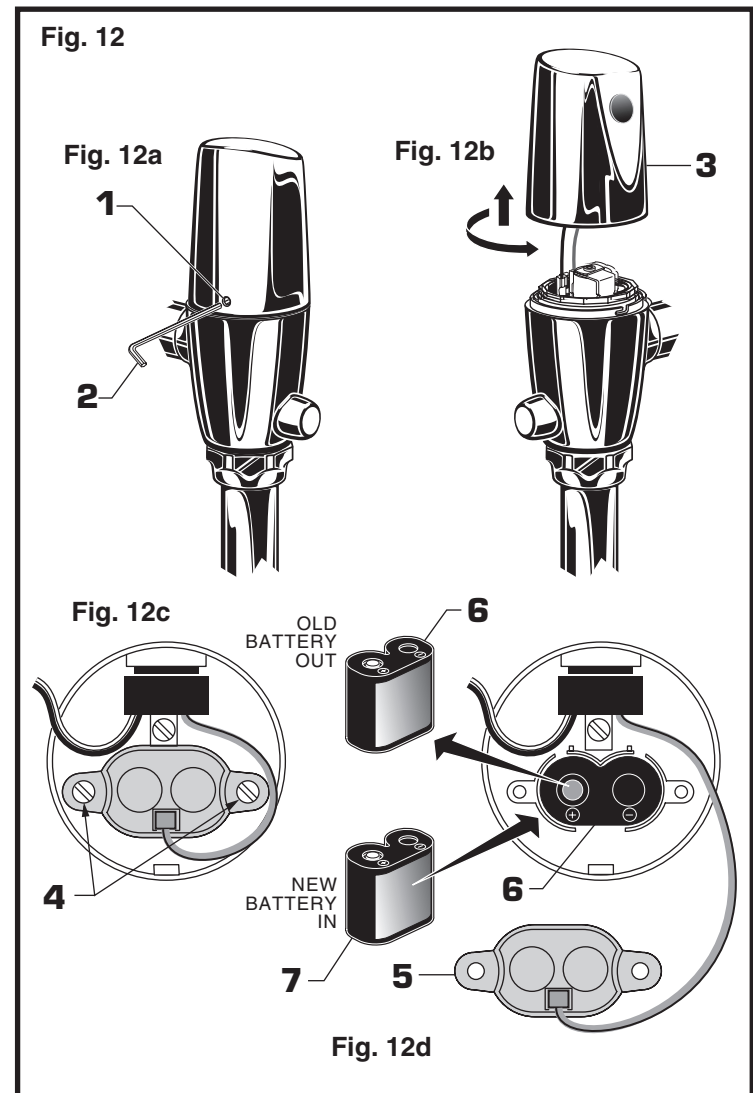

## 10 HOW TO SET DETECTION RANGE (If Required) ; Fig. 13 & 14

**Note:** The detection distance is preset and is ideal for most installations. Should an adjustment be required follow the steps below.

1. Loosen SET SCREW (1) with 2.5mm Hex Wrench (2) in back of top half of FLUSH VALVE (3). Fig. 13a.
2. Rotate CAP (3) to the right and pull off. Fig. 13b.
3. Turn CAP (3) over and disconnect GREY SENSOR WIRE (4) from BATTERY COVER (5).
4. Keeping hands away from the front of the sensor, reconnect the GREY SENSOR WIRE (4) and quickly place the CAP (3) on the valve. Do not secure the CAP (3) at this time. **Note: You have 5 seconds after connecting cable to enter program code.**
5. While the SENSOR CONTROL LED (6) is blinking slowly, place your hand 1 to 2 in. (30-50mm.) in front of the sensor. Fig. 14a.
6. When the LED (6) stops blinking and stays "ON", move your hand to the desired position from sensor (detection zone, 1-1/2" to 31", 38 to 787mm.) and hold in place until the LED (6) begins to blink again. Fig. 14b. **Note: Detection Zone is 1-1/2" to 31", 38 to 787mm from sensor.**
7. Once the SENSOR CONTROL LED (6) begins to blink again, remove your hand from the detection zone. When the flashing stops, the detection distance is set.
8. Replace and secure CAP (3) onto valve.
9. Actuate the FLUSH VALVE:
  - A) Cover sensor with hand for 10 seconds. **NOTE: Stand outside of sensor detection area.**
  - B) Remove hand from in front of the sensor; unit will flush in approximately 3 seconds.

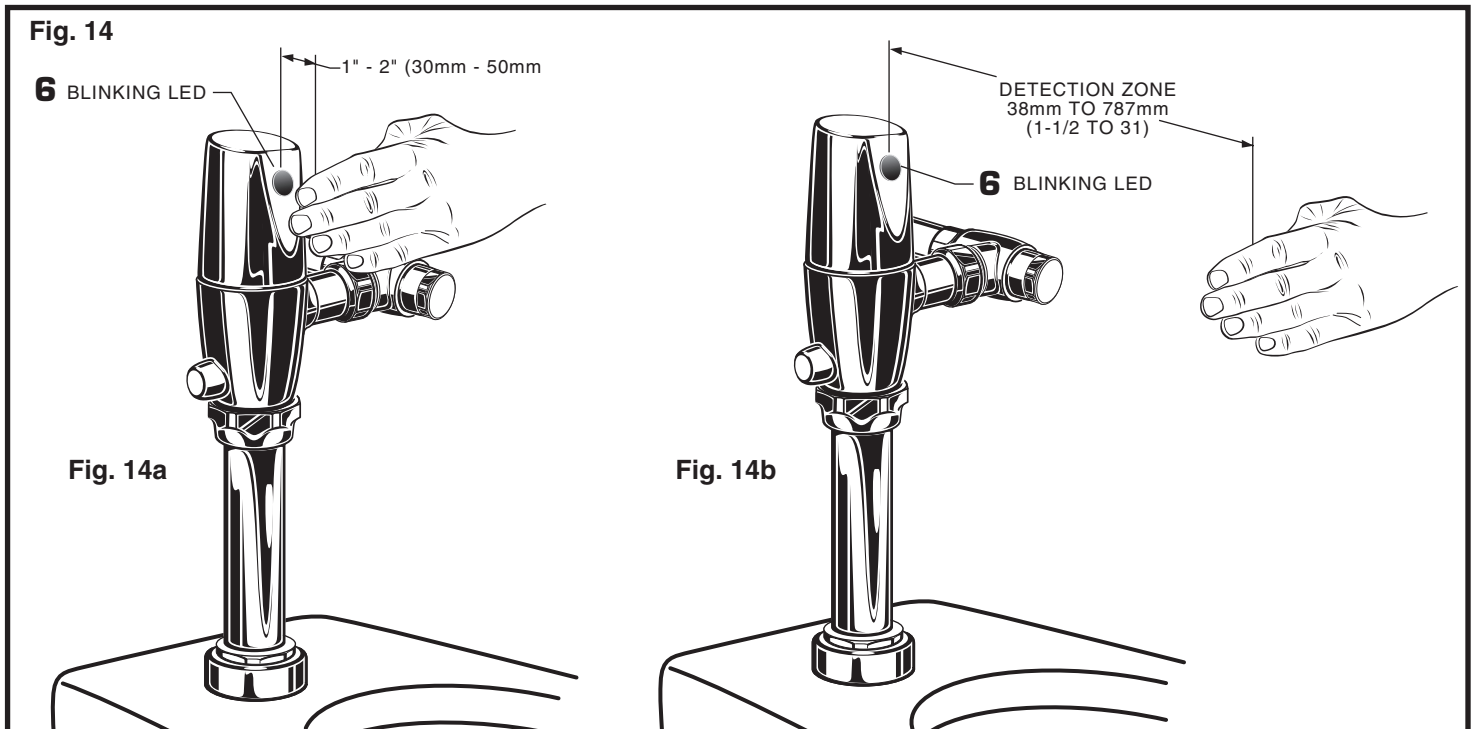
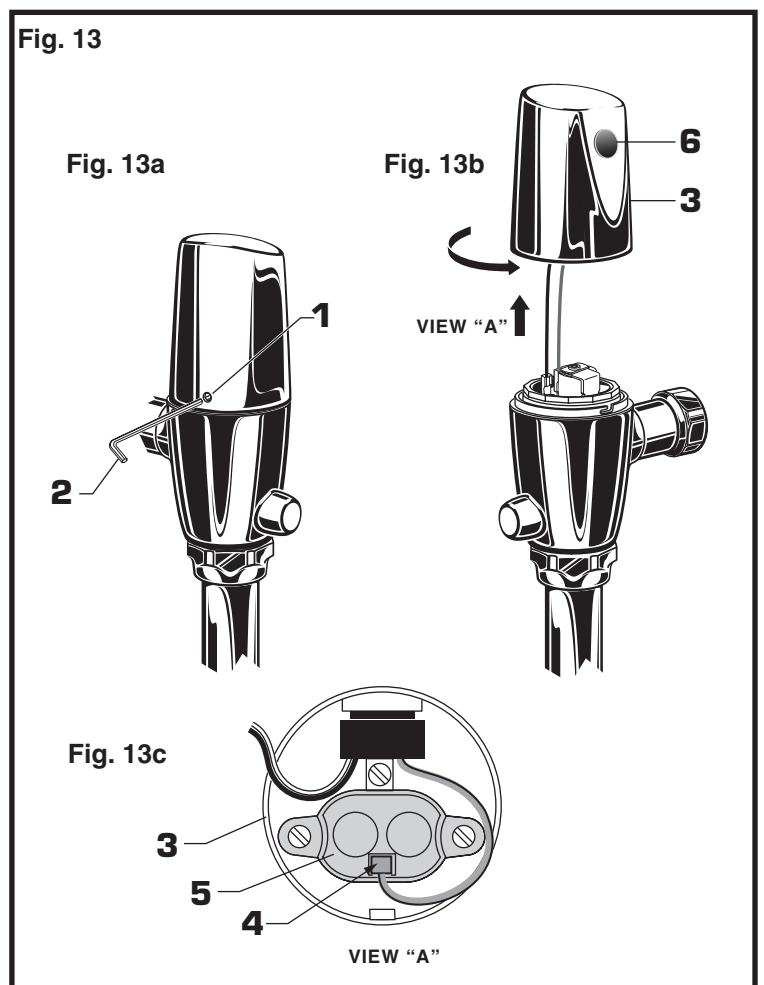



**UNIT DOES NOT FLUSH AT ALL**

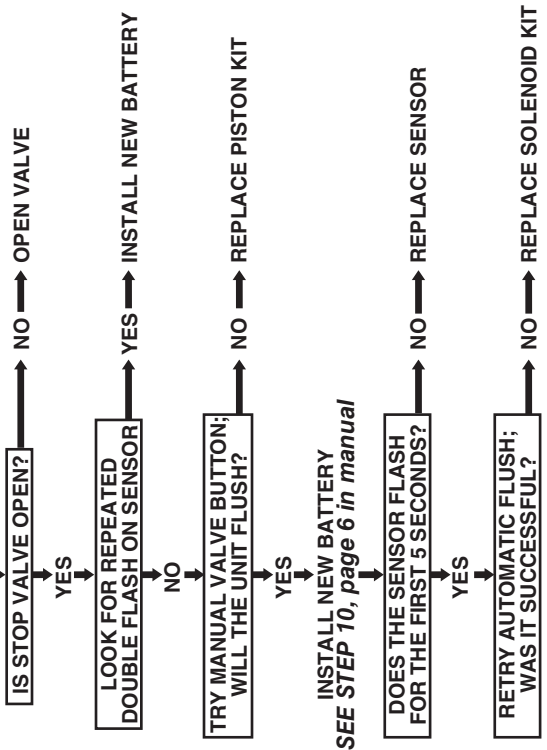

**UNIT IS CONTINUOUSLY FLUSHING**

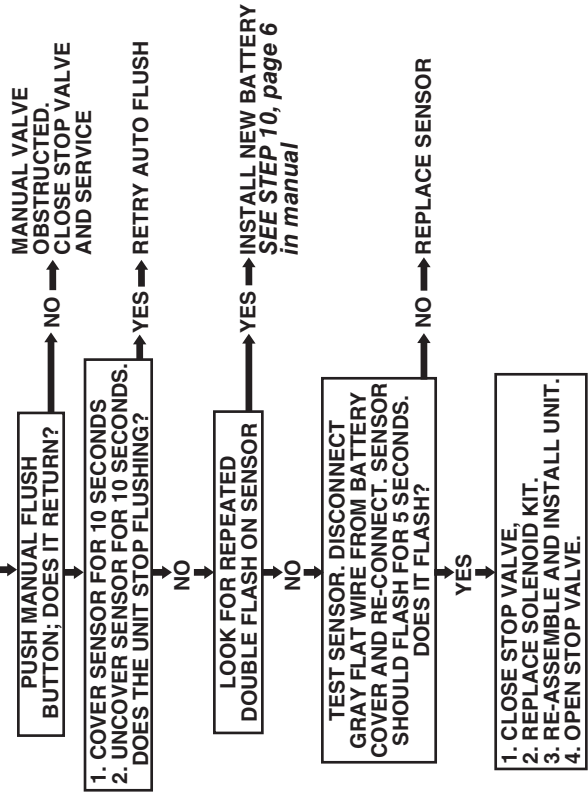

**UNIT WILL ONLY FLUSH MANUALLY**

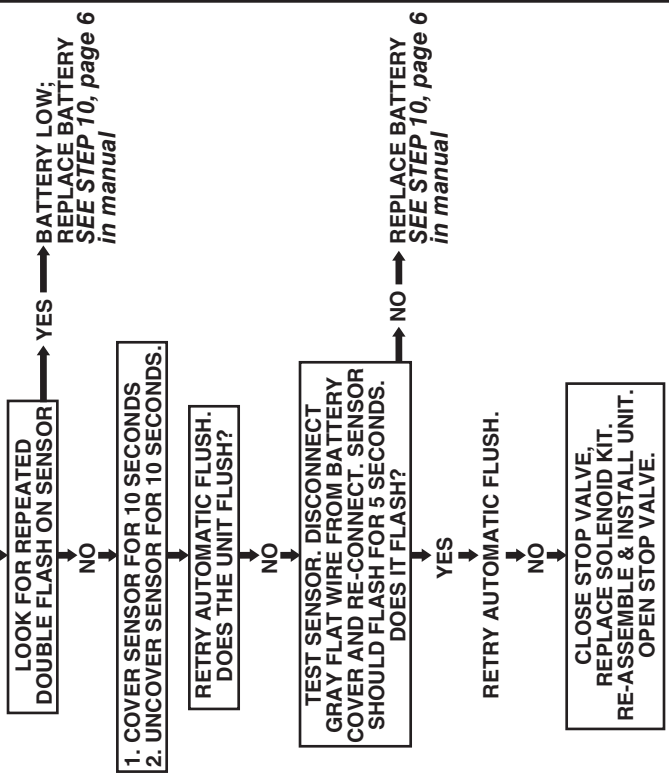

**TROUBLESHOOTING FLOW CHARTS**



**HOT LINE FOR HELP**  
 For toll-free information and answers to your questions, call:  
 1 (800) 442-1902  
 Weekdays 8:00 a.m. to 6:00 p.m. EST  
 IN MEXICO 01-800-839-1200  
 IN CANADA 1-800-387-0369 (TORONTO 1-905-306-1093)  
 Weekdays 8:00 a.m. to 7:00 p.m. EST  
 Product names listed herein are trademarks of AS America, Inc.

# American Standard

## SELECTRONIC™ PROXIMITY TOILET FLUSH VALVE 1.6 & 1.28 GPF

PRODUCT NUMBERS

6065.161	6065.162
6065.121	6065.122
6065.565	6065.525

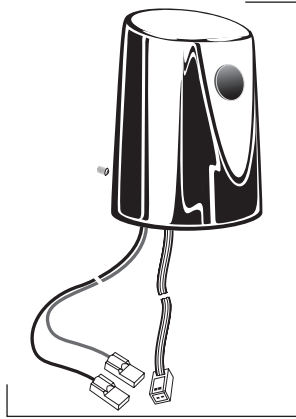

**M962665-0021600A**  
COVER ASSEMBLY FOR  
FLUSH VALVE WITH 1.6 gpf  
(BATTERY INCLUDED)

**M962665-0021280A**  
COVER ASSEMBLY FOR  
FLUSH VALVE WITH 1.28 gpf  
(BATTERY INCLUDED)



**A923654-0070A**  
BATTERY 6VCR-P2

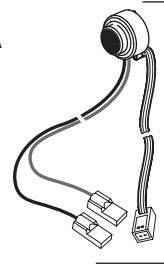

**A950223-0071600A**  
SENSOR ASSEMBLY  
W/MTG. KIT.  
FOR FLUSH VALVE  
WITH 1.6 gpf

**A950223-0071280A**  
SENSOR ASSEMBLY  
W/MTG. KIT.  
FOR FLUSH VALVE  
WITH 1.28 gpf

**A906680-0070A**  
BONNET NUT



**M962664-0070A**  
SOLENOID ASSEMBLY

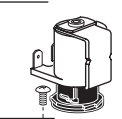

**M962663-0070A**  
PISTON ASSEMBLY

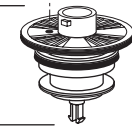

OPTIONAL ADJUSTABLE TAILPIECE  
(Purchased Separately)

**M962836-0020A** (8-1/2 to 9-1/4 Rough-in)  
**M962835-0020A** (7-1/2 to 8-1/4 Rough-in)  
**M962834-0020A** (6-1/2 to 7-1/4 Rough-in)  
**M962833-0020A** (5-1/2 to 6-1/4 Rough-in)

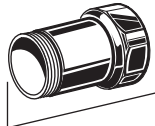

**A955066-0020A**  
ADJUSTABLE TAILPIECE  
(4-1/2 to 5-1/4 Rough-in)

**M962666-0020A**  
MANUAL VALVE

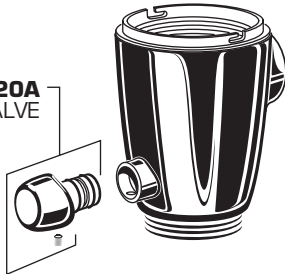

**A955057-0020A**  
INLET PIPE ASSEMBLY

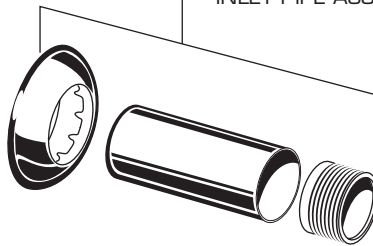

**A955056-0020A**  
1" SUPPLY STOP

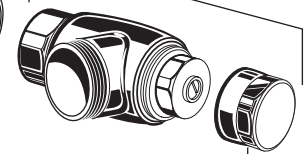

**A924349-0020A**  
CAP FOR 1" SUPPLY

**A955054-0020A**  
VACUUM BREAKER  
ASSEMBLY 11-1/2"  
(220mm) ROUGH-IN



**A955068-0020A**  
VACUUM BREAKER  
ASSEMBLY 27"  
(610mm) ROUGH-IN

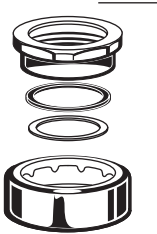

**M952269-0020A**  
ESCUTCHEON KIT



HOT LINE FOR HELP  
For toll-free information and answers to your questions, call:  
1 (800) 442-1902  
Weekdays 8:00 a.m. to 6:00 p.m. EST  
IN MEXICO 01-800-839-12-00  
IN CANADA 1-800-387-0369 (TORONTO 1-905-306-1093)  
Weekdays 8:00 a.m. to 7:00 p.m. EST

Product names listed herein are trademarks of AS America, Inc.

# Installation Instructions

## COMMERCIAL TOILET SEATS

MODELS: 5901 Elongated Heavy Duty  
5905 Elongated Extra Heavy Duty  
5910 Elongated Extra Heavy Duty Plus

Thank you for selecting American-Standard...the benchmark of fine quality for over 100 years. To ensure that your installation proceeds smoothly — please read these instructions carefully before you begin.

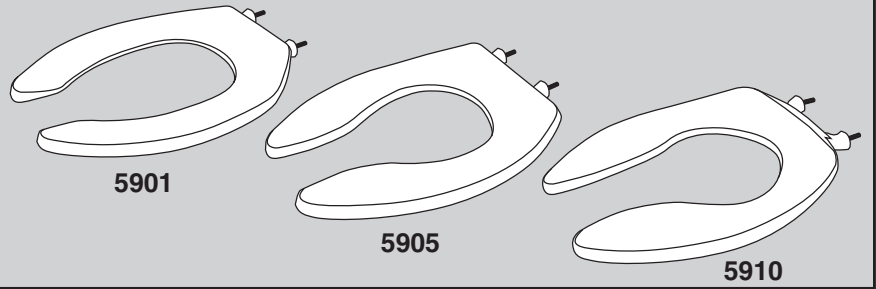

### Side View of the toilet seat installation parts.

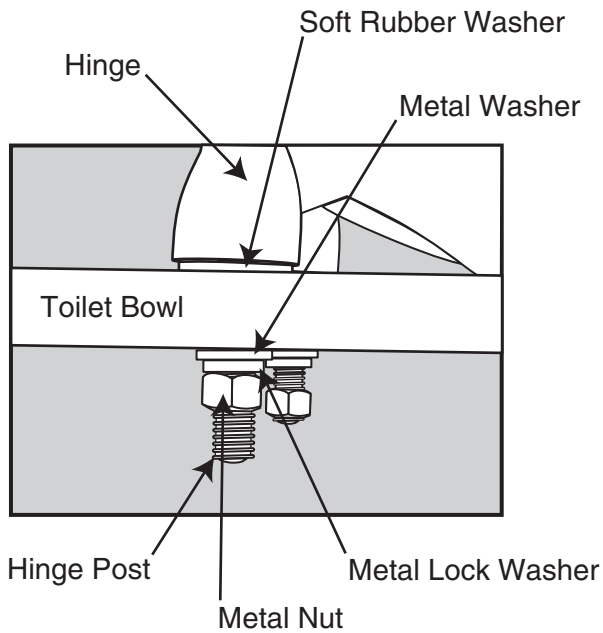

1

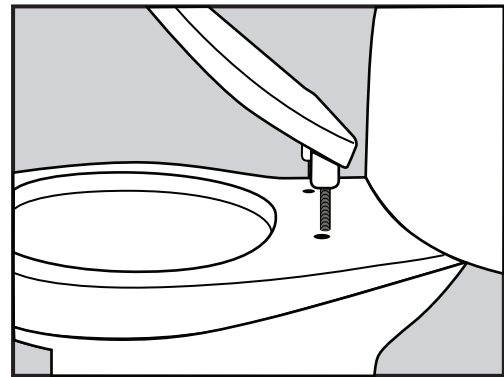

1. Insert the hinge posts into the bowl bolt holes making sure that the soft rubber washer is beneath the hinge and on top of the toilet bowl.

2

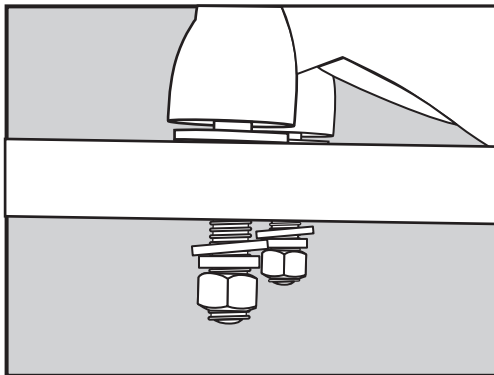

2. Properly align the toilet seat and install the metal washer, metal lock washer and metal nut onto the hinge post.

3

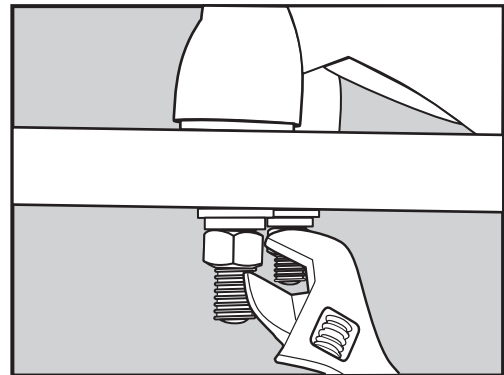

3. Tighten the nut on the hinge post using a wrench. **Caution:** Do not over-tighten the bolts as it could crack the toilet bowl.

## Care and Cleaning

When cleaning your toilet seat wash it with a mild, soapy water: rinse the seat thoroughly with clear water and dry with a soft cloth.

Avoid detergents, disinfectants, or cleaning products in aerosol cans. Never use abrasive scouring powders on your seat. Some bathroom chemicals and cosmetics may damage the seat's finish. After installation, check the tightness of the bolts from time to time to ensure a tight fit.

## AMERICAN STANDARD ONE-YEAR LIMITED WARRANTY

If inspection of this American Standard plumbing product, within one year after its initial installation, confirms that it is defective in materials or workmanship, American Standard will repair or, at its option, exchange the product for a similar model.

This limited warranty does not apply to local building code compliance; since local building codes vary considerably, the purchaser of this product should check with a local building or plumbing contractor to ensure local code compliance before installation.

This warranty shall be void if the product has been moved from its initial place of installation; if it has been subjected to faulty maintenance, abuse, misuse, accident, or other damage; if it was not installed in accordance with American Standard's instructions, or if it has been modified in a manner inconsistent with the product as shipped by American Standard.

American Standard's option to repair or exchange the product under this warranty does not cover any labor or other costs of removal or installation, nor shall American Standard be responsible for any other incidental or consequential damages attributable to a product defect or to the repair or exchange of a defective product, all of which are expressly excluded from this warranty. (Some states or provinces do not allow the exclusion or limitation of implied warranties, so this exclusion may not apply to you.)

This warranty gives you specific legal rights. You may have other statutory rights that vary from state to state or from province to province, in which case this warranty does not affect such statutory rights.

For service under this warranty, it is suggested that a claim be made through the contractor or dealer from or through whom the product was purchased, or that a service request (including a description of the product model and of the defect) be sent to the following address:

### **In the United States:**

American Standard Inc.,  
P.O. Box 6820  
Piscataway, New Jersey 08855  
Attention: Director of Consumer Affairs

For residents of the United States, warranty information may also be obtained by calling the following toll free number: (800) 442-1902  
[www.americanstandard-us.com](http://www.americanstandard-us.com)

### **In Canada:**

American-Standard,  
2480 Stanfield Rd.,  
Mississauga, Ontario  
Canada L4Y 1S2

Toll Free: (800) 387-0369  
[www.americanstandard.ca](http://www.americanstandard.ca)

### **In Mexico:**

Customer Service Manager  
Ideal Standard, S.A. de C.V.  
Via Morelos #330  
Col. Santa Clara  
Ecatepec 55540 Edo. Mexico  
[www.americanstandard.com.mx](http://www.americanstandard.com.mx)