

INSTALLATION INSTRUCTIONS PE-VERGE

⚠ WARNING

This product may represent a possible shock or fire hazard if improperly installed or attached in any way. Products should be installed in accordance with these instructions, current electrical codes, and/or the current National Electric Code (NEC).

SAFETY INFORMATION

- Read all instructions before beginning. Save these instructions for future use.
- To reduce the risk of fire, electric shock, or injury to persons, pay close attention to this manual. Stay within its guidelines when using this product.
- All units must be unplugged before installing or servicing in any way.
- Do not route cords or units through walls, doors, windows, or any similar part of a building structure.
- Do not use if there is any damage to the unit. Inspect periodically.
- Secure units with mounting hardware appropriate for the mounting surface.

BEFORE INSTALLATION:

1. Get familiar with the key parts of the PE-VERGE extrusion. See FIGURE 1.
2. Determine installation location and ensure there is enough space for the extrusions, tapelight, and any cables involved.
3. Determine mounting method and fasteners required.
4. Make sure all measurements are correct. This extrusion is designed to be installed directly into drywall or stud via a mud-in method and is not easily re-installed.

FIGURE 1

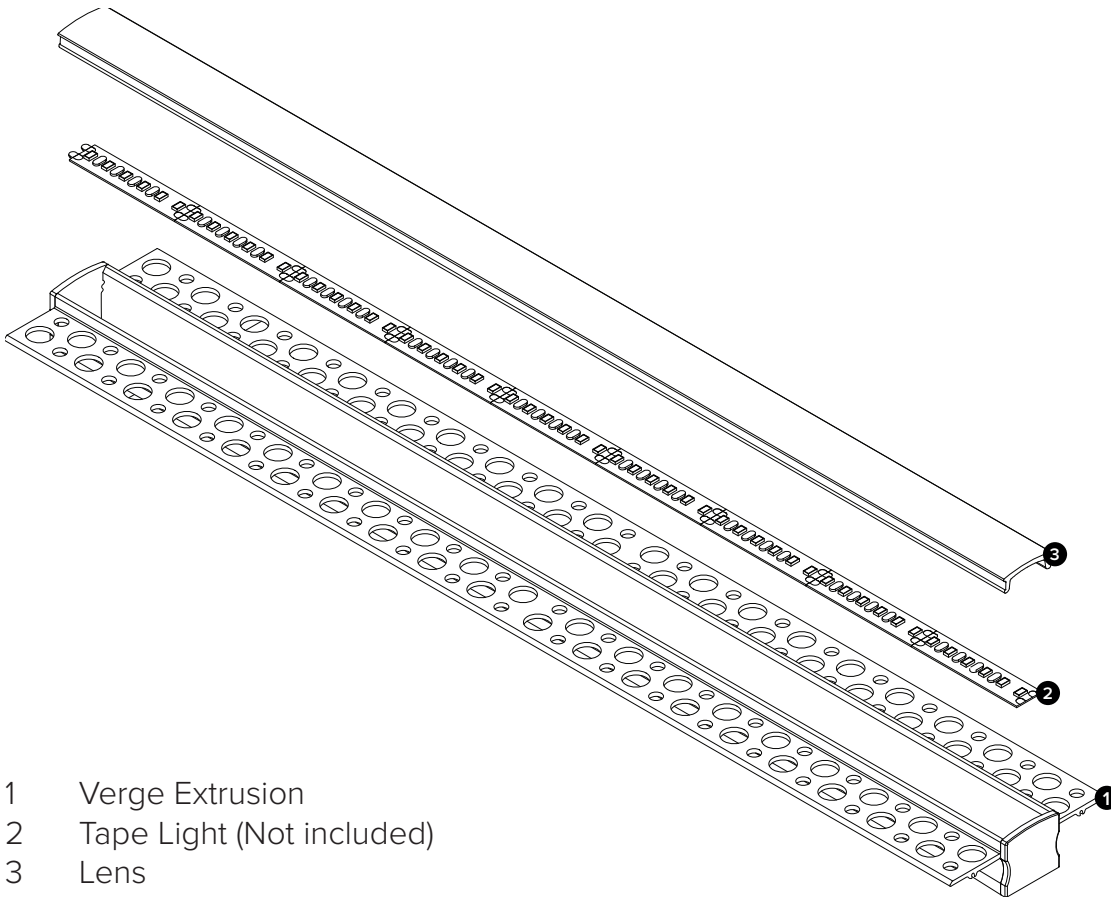

- 1 Verge Extrusion
- 2 Tape Light (Not included)
- 3 Lens

REQUIRED MOUNTING MATERIALS (Not included):

Stainless Steel Screw

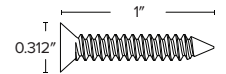

#8 x 1" Flat Head Screw

- Stainless Steel
- Indoor/Outdoor

Note: For Stud Mounting

Drywall "mud" Joint Compound



- Strong Adhesive
- Non Submersible, for Dry & Wet locations

832 Adhesive



- Strong Adhesive
- Non Submersible, for Dry & Wet locations

INSTALLATION INSTRUCTIONS

PE-VERGE

DRYWALL MOUNTING INSTALLATION:

1. Per section dimensions on product spec sheet (template recommended on ends to ensure straight cuts) cut a 3.35" parallel opening on the drywall using a jabsaw or "rotozip" tool.
2. Mount extrusion into drywall opening using 1in screws (figure 2)
 - Remove lens from extrusion
 - Mount extrusion with endcaps into 1/2" drywall
 - Drywall anchors not included
 - Make sure to leave enough space for wire exit, jumper cables, and end caps.

FIGURE 2

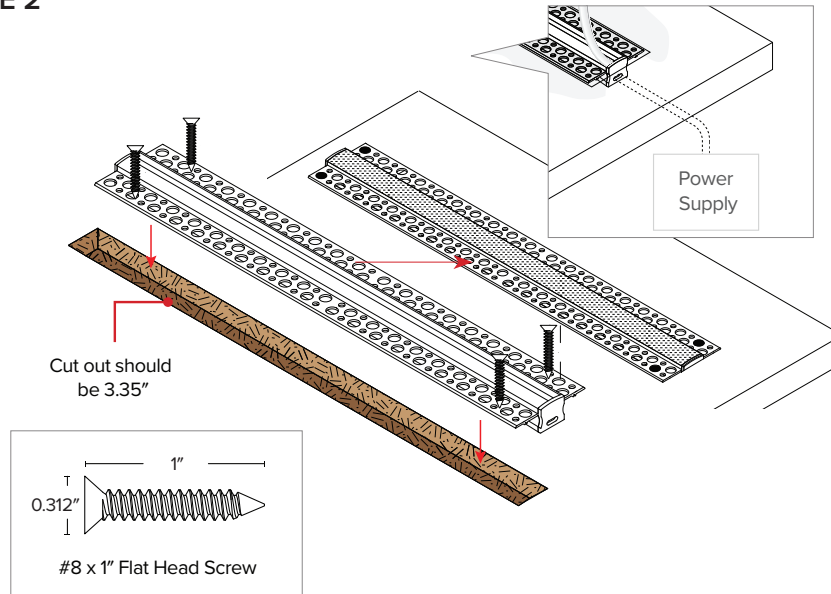

3. Prepare extrusion for mud-in plaster (figure 3)
 - Use drywall tape to cover flanges
 - Use masking tape to cover the inside of the extrusion channel

FIGURE 3

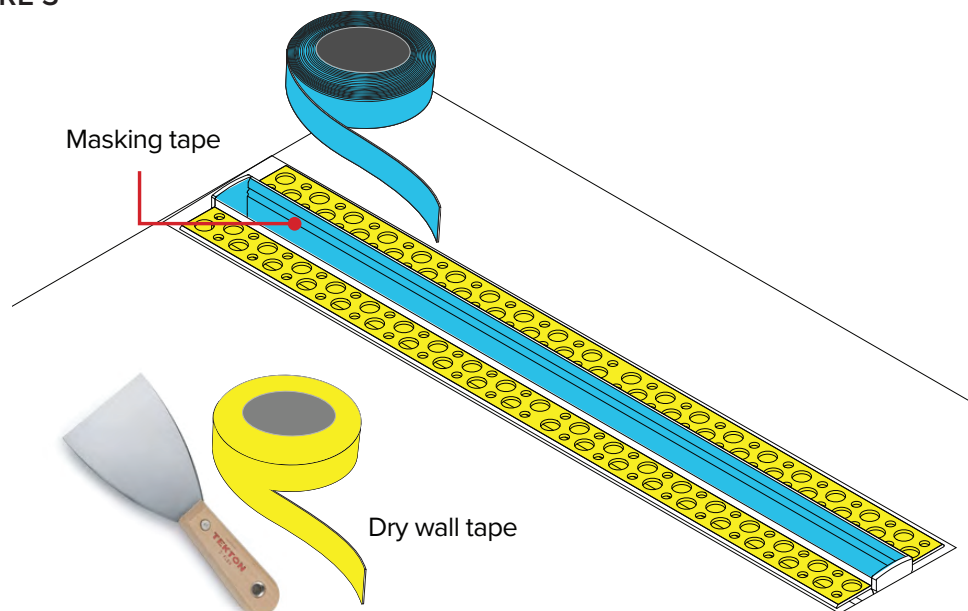

INSTALLATION INSTRUCTIONS

PE-VERGE

DRYWALL MOUNTING INSTALLATION CONT:

4. Apply mud-in plaster (figure 4)
 - Use an adequate to generous amount of mud to cover the extrusion wings and additional area surrounding extrusion wings
 - Ensure mud is at least as deep after finishing as the lens regression of the recess in the extrusion.
5. Use extensive amount of mud thickness past the extrusion wings. Taper as far as necessary to ensure smooth finish with no apparent elevation change or bump.

FIGURE 4

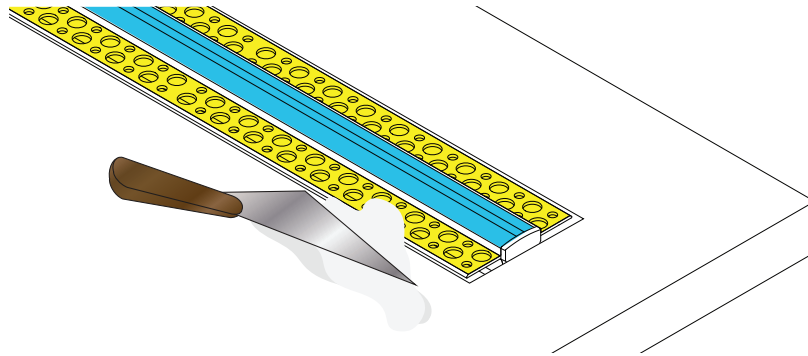

6. Remove masking tape and clean the inner channel (figure 5)
 - Using a 50/50 alcohol mix, thoroughly clean the surface of the extrusion allow time to dry (about 5 minutes)

FIGURE 5

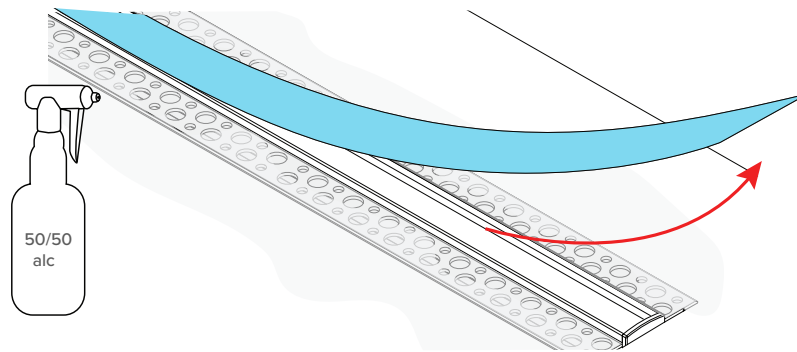

7. Install LED tape light (figures 6 & 7)
 - Feed the wire to the power supply, then install the LED strip
 - Insert the lens, paint wall, then remove protective film after painting

FIGURE 6

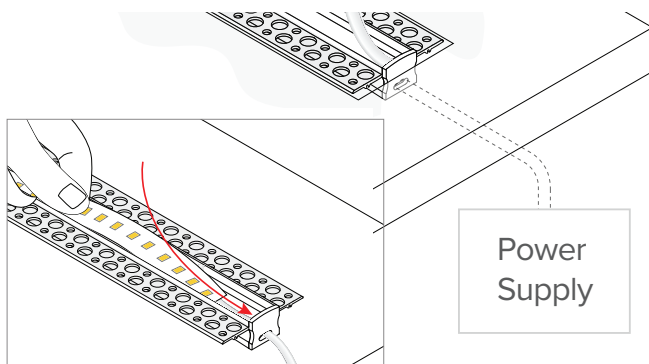
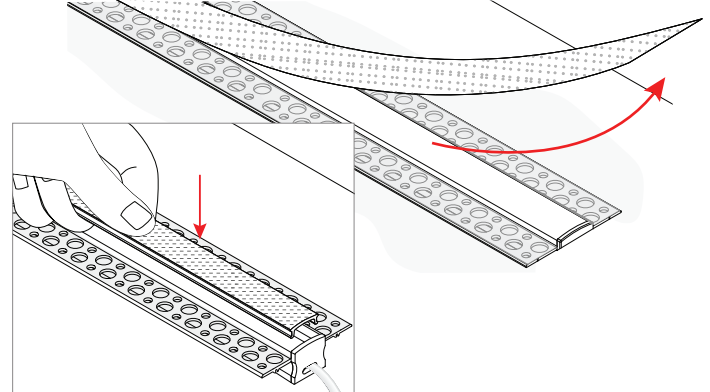

FIGURE 7



INSTALLATION INSTRUCTIONS

PE-VERGE

STUD MOUNTING INSTALLATION:

1. Per section dimensions on product spec sheet (template recommended on ends to ensure straight cuts) cut a 3.35" parallel opening in drywall above stud using a jabsaw or "rotozip" tool.
2. Mount extrusion directly into stud via opening (figure 8)
 - Remove lens from extrusion
 - Mount extrusion with endcaps into 1/2" drywall
 - Drill holes in back of extrusion and screw directly into the stud
 - Make sure to leave enough space for wire exit, jumper cables, and end caps.

FIGURE 8

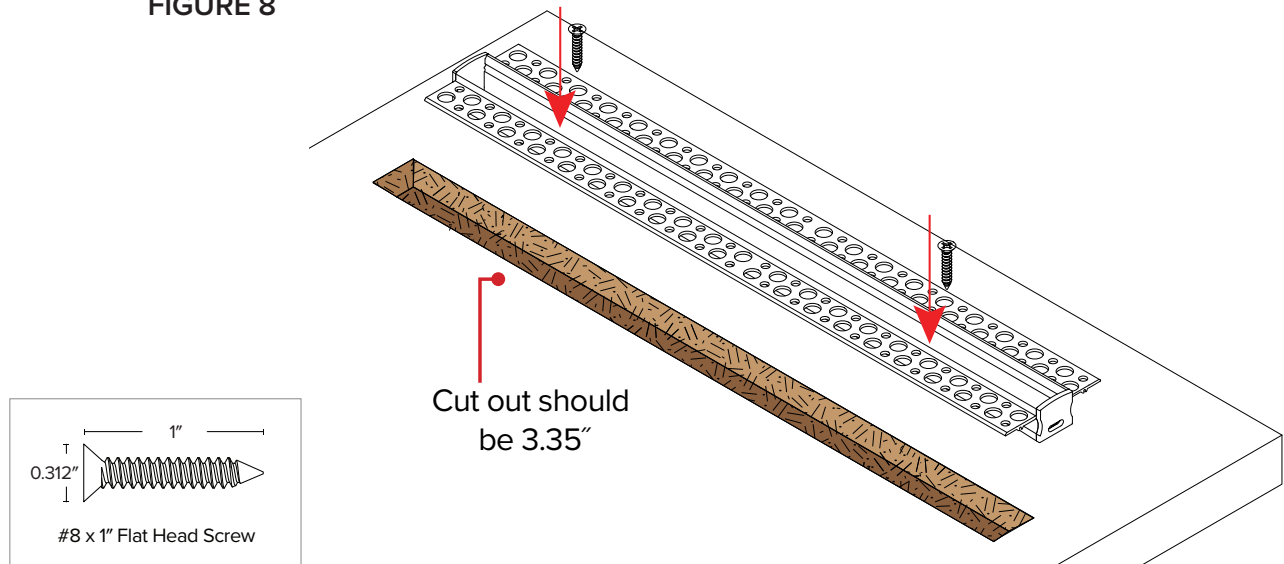

3. Prepare extrusion for mud-in plaster (figure 9)

- Use drywall tape to cover flanges
- Use masking tape to cover the inside of the extrusion channel

FIGURE 9

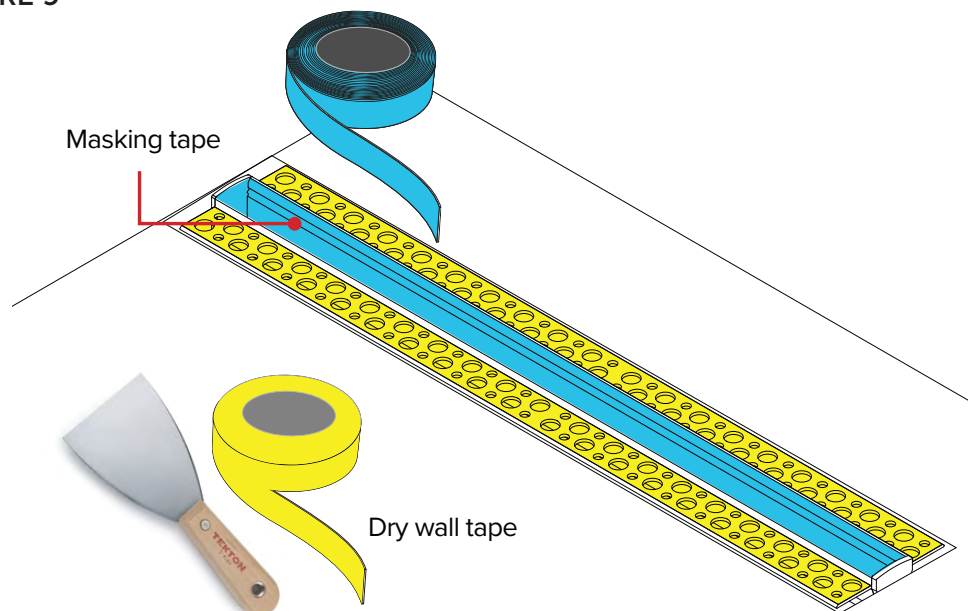

INSTALLATION INSTRUCTIONS

PE-VERGE

STUD MOUNTING INSTALLATION CONT:

4. Apply mud-in plaster (figure 10)
 - Use an adequate to generous amount of mud to cover the extrusion wings and additional area surrounding extrusion wings
 - Ensure mud is at least as deep after finishing as the lens regression of the recess in the extrusion.
5. Use extensive amount of mud thickness past the extrusion wings. Taper as far as necessary to ensure smooth finish with no apparent elevation change or bump.

FIGURE 10

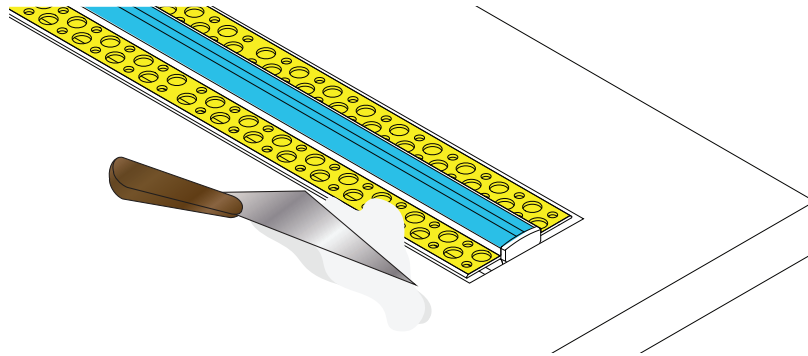

6. Remove masking tape and clean the inner channel (figure 11)

- Using a 50/50 alcohol mix, thoroughly clean the surface of the extrusion allow time to dry (about 5 minutes)

FIGURE 11

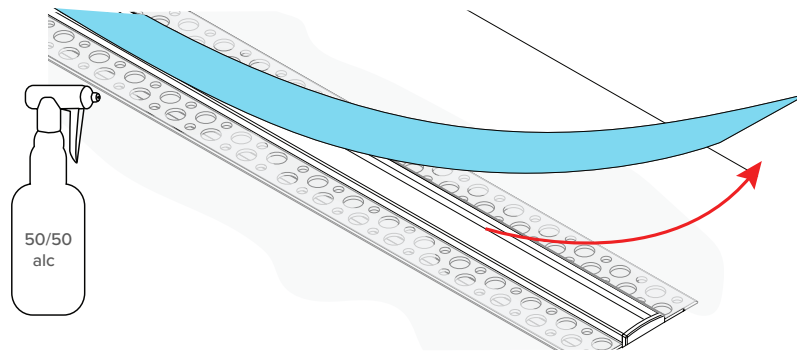

7. Install LED tape light (figures 12 & 13)

- Feed the wire to the power supply, then install the LED strip
- Insert the lens, paint wall, then remove protective film after painting

FIGURE 12

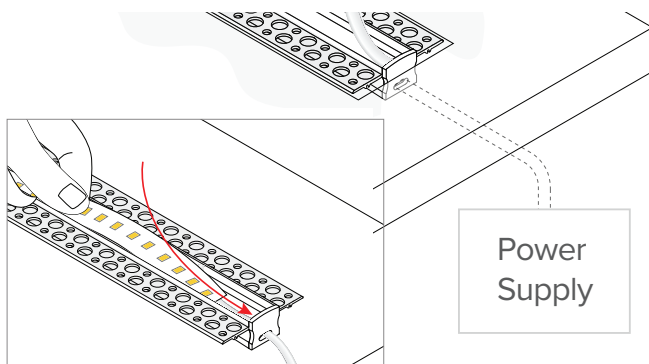

FIGURE 13

