

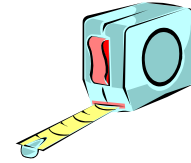

IMPORTANT



Templates must be printed without size modifications and verified for dimensional accuracy.

- Before printing, select the printing options necessary to ensure that copies are produced without size adjustments.
- After printing, measure the dimensions indicated on the template to ensure correct scale.

ET-PDL

Trilogy® Panic Exit Device Trim



INSTRUCTIONS & TEMPLATE

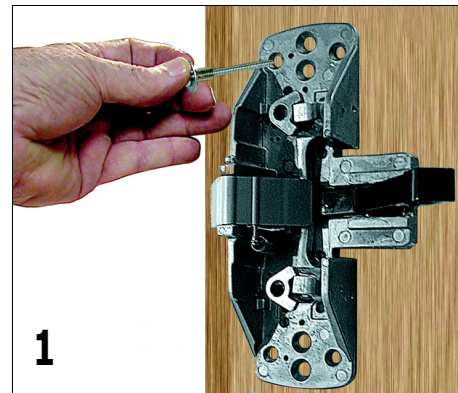

1. Existing Installation: Remove Exit device from door.



3. Position Exterior assembly on door.

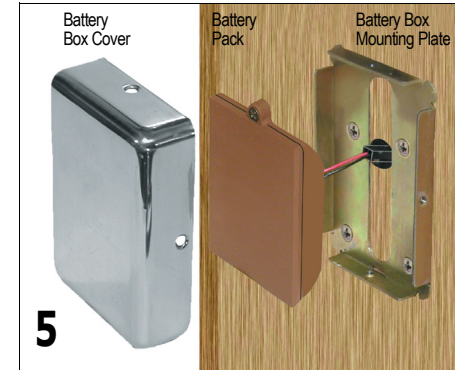

5. Connect battery pack and place inside of battery mounting plate. Position cover and fasten with three #6-32 x 5/16" screws.

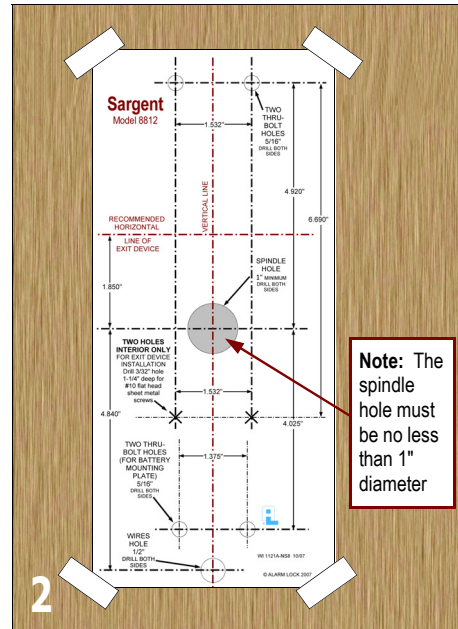

2. Existing Installation: Position Alarm Lock template on horizontal & vertical lines of existing spindle hole.
New Installation: Locate and mark horizontal and vertical lines indicated in Exit Device Instructions/Template. Line up Alarm Lock template with horizontal and vertical lines and tape on door.
Existing and New Installations: Mark all hole centers on each side of door. Drill all holes from both sides of door to avoid splintering.

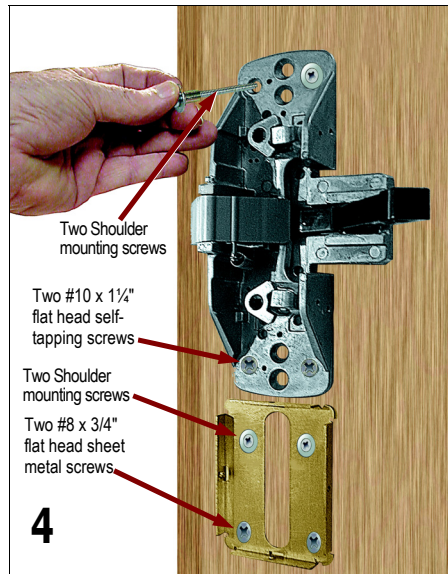

4. Replace Exit Device, insert and fasten with 2 new Shoulder mounting screws, on top of Exit Device into mounting posts. Fasten two #10 x 1-1/4" flat head sheet metal screws in lower mounting holes. Do not over-tighten. Pull wires from door through Battery Mounting Plate. Do not pinch or cut wires. Position plate below Exit Device and fasten with two Shoulder screws on top, into mounting posts and two #8 x 3/4" flat head sheet metal screws on the bottom.



6. Replace and fasten Exit device & Battery box covers.

Check lock for proper operation before closing door.

Sargent Model 8812

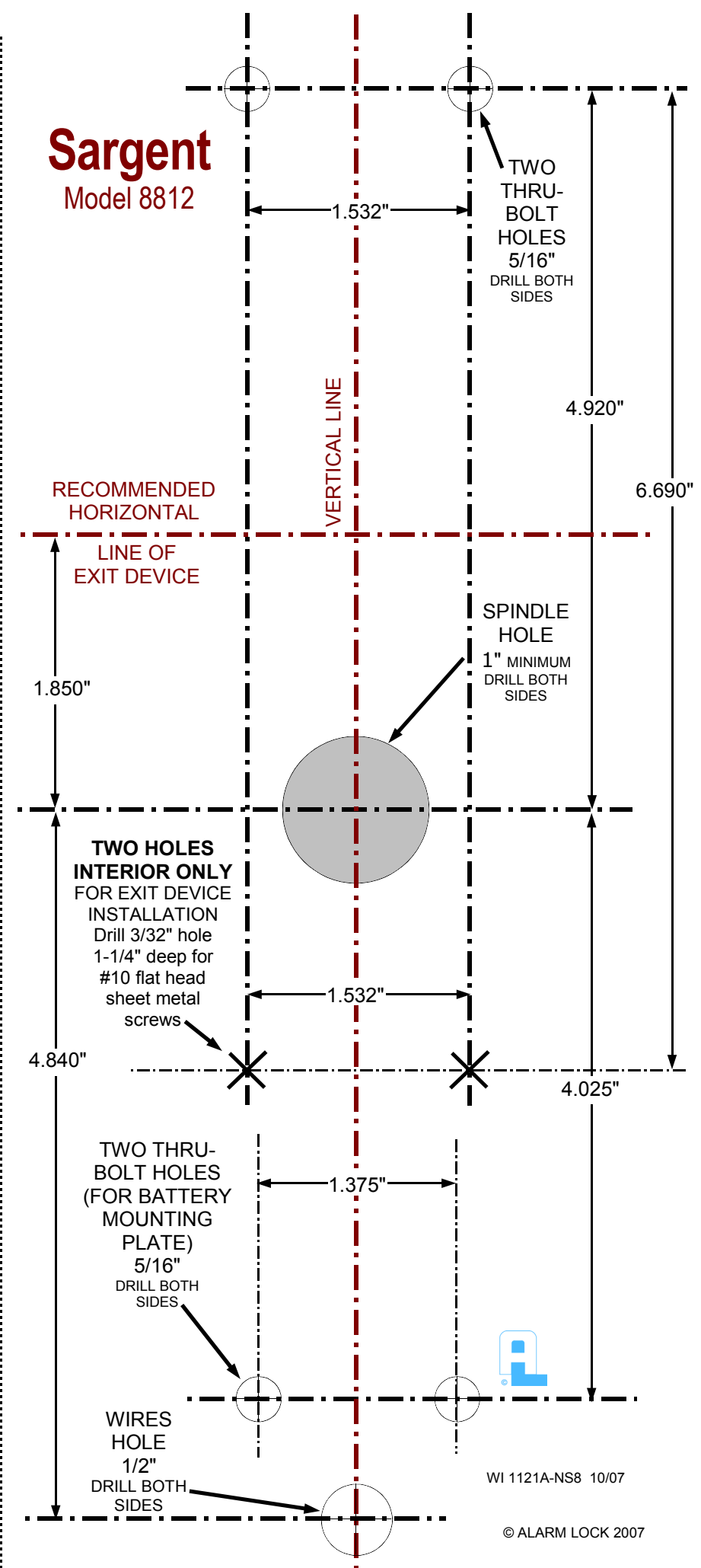

NEW Sargent Model 8812 Rim Exit Device

To Change Cylinder

IMPORTANT:
 When replacing cylinder be sure to use the proper Cylinder Adapter and Tailpiece.

Alarm Lock Systems, Inc.
 A division of the NAPCO Security Group
 345 Bayview Avenue, Amityville, NY 11701
 Tel: (631) 789-4871 Fax: (631) 789-3383
 www.alarmlock.com
 Publicly traded on NASDAQ Symbol: NSSC

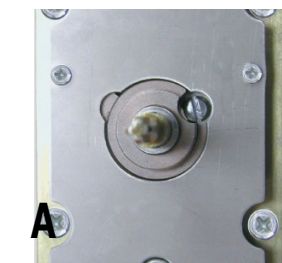
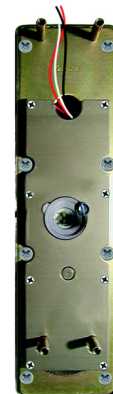

A. Remove Cover plate. Rotate the spindle either direction to expose and remove cylinder screws.

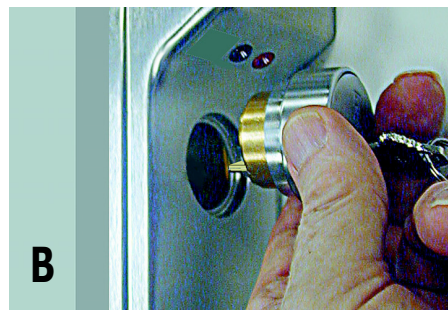

B. Remove old cylinder and insert new cylinder.

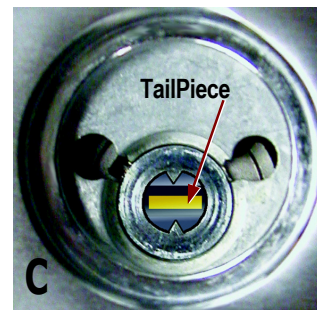

C. Note: The tailpiece must be in the horizontal position as shown in the image above.

WI 1121A-NS8 10/07

© ALARM LOCK 2007