

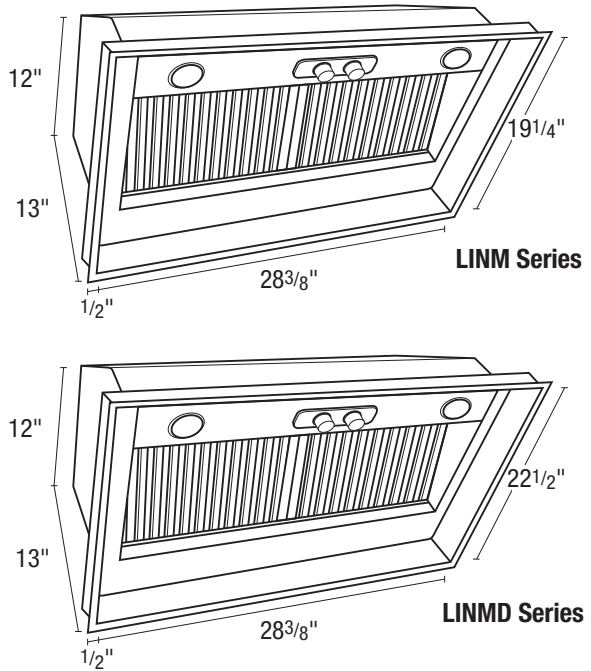

SPECIFICATIONS
LIN28M
 POWER UNIT LINER

	LIN28m-300, 300 CFM/4.5 Sones @ 0.10" SP.	LIN28md-300, 300 CFM/4.5 Sones @ 0.10" SP.
	LIN28m-400, 400 CFM/8.0 Sones @ 0.10" SP.	LIN28md-400, 400 CFM/8.0 Sones @ 0.10" SP.
	LIN28m-600, 600 CFM/5.5 Sones @ 0.10" SP.	LIN28md-600, 600 CFM/5.5 Sones @ 0.10" SP.

- **Hood**
Galvanized metal body with all exposed areas grade 430 stainless steel. Approved for installation into covered outdoor kitchen areas.
- **Thermostat (LIN28m-600, LIN28md-600 models only)**
Thermostat detects when the heat level rises to an excessive amount and automatically turns the hood on.
- **Blower Wheel**
3 speed motor with electronically balanced polymeric centrifugal blower wheel. Rated 120 volts, 60 hz.
- **Lighting**
2 - PAR16 type A screw-in base, 45 watt maximum Halogen lamps (included).
- **Ducting Options**
Vertical outlet only. Vertical or Horizontal ducting transition achieved through vertical or horizontal duct adapter (vertical adapter included) specified for size of motor.
- **Filters**
Grease Baffles: Dishwasher safe, Stainless Steel baffles (included).
- **Available Finishes**
Brushed Stainless Steel - #4 finish
- **Opening Size**
LIN28m: 28³/₈" x 19¹/₄" (Fits cabinets 30" wide)
LIN28md: 28³/₈" x 22¹/₂" (Fits cabinets 30" wide)



NOTE: 1/2" wide trim flange around the entire perimeter of the face plate

EXPANDED PERFORMANCE										
Air Flow - CFM	Static Pressure (inches of w.g.)						Sones @ .1 SP	Fan Speed RPM	Blower Watts	Full Load Amps
	0	0.1	0.15	0.25	0.3	0.375				
300 CFM Blower	315	300	292	271	259	238	4.5	1490	89.9	2.0
400 CFM Blower	425	400	387	358	340	308	8.0	1711	214.0	3.6
600 CFM Blower	638	600	581	537	510	458	5.5	1492	164.0	1.75

PROJECT							ARCHITECT			
LOCATION							ENGINEER			
CONTRACTOR							SUBMITTED BY			DATE
FAN NUMBER	MODEL NUMBER	CFM	IN W.C.	RPM	WATTS	AMPS	SONES	QTY	OPTIONAL EQUIPMENT & REMARKS	



U.S.: 820 Lincoln Avenue
 West Chester, Pennsylvania 19380-4466
 Tel: (610) 692-7400 • 877-304-3785
 Fax: (610) 696-8048

Canada: 8 Edvac Drive
 Brampton, Ontario L6S 5P2
 Tel: (905) 456-2033 • 800-250-8767
 Fax: (905) 456-1015