



**SPECIFICATIONS**

**APDQ**  
RANGE HOODS

**HVI 2100 CERTIFIED** **300 CFM/5.5 Sones @ 0.10" SP. Horizontal**  
**300 CFM/5.5 Sones @ 0.10" SP. Vertical**

• **Dimensions**

Overall bottom projection - 22"  
Height - 7 1/2"  
Widths - 30", 36"

• **Hood Body**

Stainless Steel: 24 gauge, grade 430 stainless steel.

• **Motor**

Variable speed, thermally protected, permanently lubricated motor.  
Rated 120 volts, 60 hz. with two electronically balanced blower wheels.

• **Lighting**

Two - GU10 base, MR16, 50 watt halogen lights (bulbs not included).

• **Ducting Options**

Horizontal ducting: 3 1/4"x10" (duct adapter and damper included).  
Vertical ducting: 3 1/4"x10" (duct adapter and damper included).  
Ductless: top vent (charcoal filter not included).

• **Mounting**

Wall mounted. Install 20" to 30" from cooking surface.

• **Filters**

Grease Filter: GF-01 (included).  
Charcoal Filter: CF-01 (not included).

• **Available Finishes**

Stainless Steel

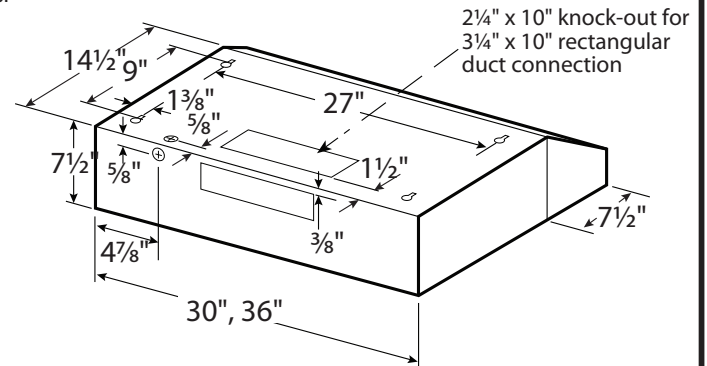
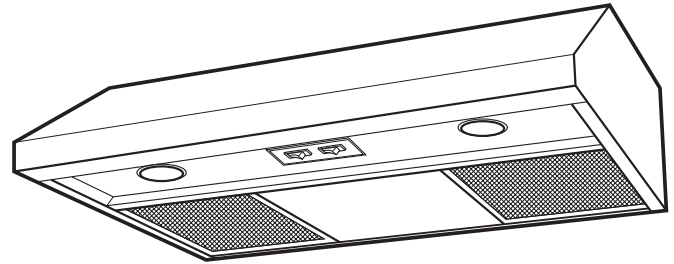

**EXPANDED PERFORMANCE**

Air Flow - CFM	Static Pressure (inches of w.g.)						Sones @ .1 SP	Fan Speed RPM	Power Watts	Apms
	0	0.05	0.1	0.15	0.2	0.25				
Vertical Ducting High	337	324	300	294	277	258	5.5	1575	114.0	1.5
Horizontal Ducting High	330	317	300	280	259	239	5.5	1560	114.0	1.5

<b>PROJECT</b>							<b>ARCHITECT</b>				
<b>LOCATION</b>							<b>ENGINEER</b>				
<b>CONTRACTOR</b>							<b>SUBMITTED BY</b>			<b>DATE</b>	
FAN NUMBER	MODEL NUMBER	CFM	IN W.C.	RPM	WATTS	AMPS	SONES	QTY	OPTIONAL EQUIPMENT & REMARKS		



**U.S.:** 820 Lincoln Avenue  
West Chester, Pennsylvania 19380-4466  
Tel: (610) 692-7400 • 877-304-3785  
Fax: (610) 696-8048

**Canada:** 8 Edvac Drive  
Brampton, Ontario L6S 5P2  
Tel: (905) 456-2033 • 800-250-8767  
Fax: (905) 456-1015