

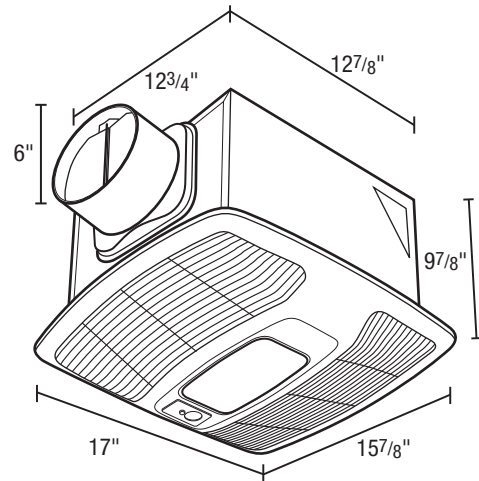

SPECIFICATIONS  
**EL130SGH**  
 EXHAUST FAN

**HVI** 2100 CERTIFIED **130 CFM / <0.3 Sones @ 0.10" SP.**  
**112 CFM @ 0.25 SP. (Boost)**

- **Grill**  
White, polymeric grill secured in place with torsion springs; easily removed if necessary, dimensions - 17" x 15 7/8".
- **Blower Wheel**  
Balanced polymeric dual inlet blower wheel secured in place using a hex nut.
- **Motor**  
Enclosed 4 pole high efficiency, permanently split capacitor motor (PSC); life time lubrication, suitable for continuous operation. Rated 115/120 volts, 60 Hz.
- **Fan Housing**  
23 gauge galvanized steel housing. Fan housing dimensions: 12 7/8" x 12 3/4" x 9 7/8".
- **Motion Sensor**  
Integrated motion sensor automatically turns fan to high speed when room is occupied. Adjustable off delay from 30 seconds to 80 minutes.
- **Humidity Sensor**  
Integrated humidity sensor, adjustable up to 80% RH automatically turns fan to on until humidity drops to the desired set point.
- **Duct Collar**  
6" round, zinc plated metal collar adapter. 6" spring loaded and gasketed aluminum backdraft damper.
- **Electrical Connections**  
0.5" electrical knockouts provided. Easy wiring access via either internal or external wiring compartment cover.
- **Lighting**  
GU24 base, 8 Watt 4000K LED Lamp, 725 Lumens (91 Lumens/Watt)  
4 watt night light (night light bulb not included).



Acceptable for use over tub or shower when installed in a GFCI protected branch circuit.



- **Unit Mounting**  
The housing will mount through drywall thickness up to 3/4", with a rough-in opening of 13 1/8" x 13". The housing will mount either between 16" or 24" on center joists, using the 2 supplied housing mounting brackets. The housing mounting brackets can be adapted for overhead mounting (hardware not provided). The unit is provided with an optionally installed ceiling flange to ensure proper building infiltration rates are maintained and that no air leaks occur between the fan housing and ceiling cutout.

EXPANDED PERFORMANCE											
	Static Pressure (inches of w.g.)							Sones @ .1 SP	Fan Speed RPM	Maximum Fan Watts	Full Load Amps
	0	0.1	0.15	0.2	0.25*	0.3	0.35				
<b>Air Flow - CFM</b>	149	130	119	107	91/112	79	62	<0.3	783	37.0	0.7

\* Boost speed provides 112 CFM @ .25 Static Pressure, 0.6 sones

<b>PROJECT</b>							<b>ARCHITECT</b>				
<b>LOCATION</b>							<b>ENGINEER</b>				
<b>CONTRACTOR</b>							<b>SUBMITTED BY</b>			<b>DATE</b>	
FAN NUMBER	MODEL NUMBER	CFM	IN W.G.	RPM	WATTS	AMPS	SONES	QTY	OPTIONAL EQUIPMENT & REMARKS		



**U.S.:** 820 Lincoln Avenue  
 West Chester, Pennsylvania 19380-4466  
 Tel: (610) 692-7400 • 877-304-3785  
 Fax: (610) 696-8048

**Canada:**  
 Brampton, Ontario  
 Tel: 800-250-8767  
 Fax: (905) 456-1015