



SPECIFICATIONS
SEGOVIA
 WALL MOUNT RANGE HOODS

600 CFM/14.0 Sones @ 0.10" SP.

- **Dimensions**
 Overall bottom projection - 19³/₄"
 Available widths: 35⁷/₈"
- **Hood Body**
 Brushed 430 stainless steel
- **Motor**
 3 speed, permanently split capacitor motor. Rated 120 volts, 60 hz.
- **Lighting**
 Two - GU10 base, MR16, 50 watt halogen lights.
- **Ducting Options**
 Vertical ducting: 6" round duct adapter complete with back draft damper ensuring quiet operation.
 Ductless: Requires charcoal filter (not included).
- **Blower Wheel**
 Dual inlet, electronically balanced polymeric centrifugal blower wheel, 5³/₄" width 59 paddles.
- **Mounting**
 Wall mounted with included mounting bracket. Install 24" to 30" from cooking surface.
- **Filters**
 Grease Filter: BCGF-01 (included).
 Charcoal Filter: BCCF-01 (not included).
- **Available Finishes**
 Stainless Steel.

Barcelona[®]
 Collection

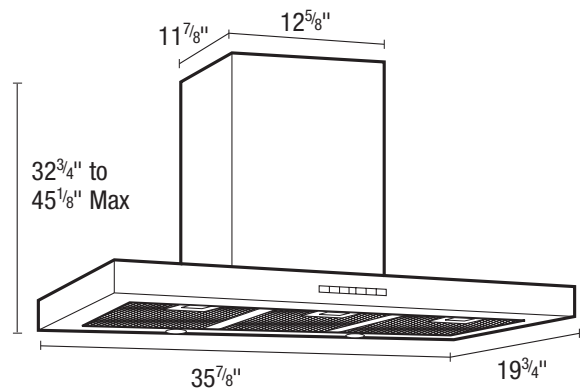

EXPANDED PERFORMANCE									
	Static Pressure (inches of w.g.)					Sones	Fan Speed	Power	
	0	0.1	0.25	0.5	0.75	@ .1 SP	RPM	Watts	Amps
Air Flow - CFM	603	600	594	578	557	14.0	2560	551.0	3.8

PROJECT				ARCHITECT					
LOCATION				ENGINEER					
CONTRACTOR				SUBMITTED BY				DATE	
FAN NUMBER	MODEL NUMBER	CFM	IN W.C.	RPM	WATTS	AMPS	SONES	QTY	OPTIONAL EQUIPMENT & REMARKS



Air King: 820 Lincoln Avenue
 West Chester, Pennsylvania 19380-4466
 Tel: (610) 692-7400 • 877-304-3785
 Fax: (610) 696-8048