

AGA Professional

30" Dual Fuel Range with RapidBake Convection™

APRO30DFSS



Oven Features

- Extra Large 4.2 cubic ft. capacity electric oven
- RapidBake Convection™ speeds 350°F pre-heat time in 13 minutes
- Easy Clean™ Technology with black vitreous enamel interior
- Cool Flow™ Range Top Technology integrated automatic cooling system clears hot air making range surface cooler to touch
- Powerful infrared convection oven Broiler with Porcelain enameled broiler pan with grid
- Electric oven includes 3 oven racks with 5 rack positions
- Two long-lasting halogen bulbs for optimal illumination while cooking



Cooktop Features

- True Dual Flame™ double ring brass burners eliminate center cold spots and provide the most even heating
- Heavy duty die-cast commercial grade metal control knobs
- Continuous, easy-to-clean matte finish cast iron grates



Cooktop Specifications

- 2 - 15,000/700 Btu
- 2 - 12,000/2,800 Btu



(800) 223.3900

www.aga-ranges.com

AGA Professional

30" Dual Fuel Range with RapidBake Convection™

APRO30DFSS



Technical Details	
Circuit Breaker (A)	30 A
Volts (V)	240 V
Frequency (Hz)	60 Hz
Power Cord	Not Included
Energy Source	Electric Ovens & Gas Cooktop
Gas Type	Natural Gas
Alternative Gas Type	Liquid Propane LP Conversion Kit Included

Dimensions & Weights	
Overall Dimensions	30"W x 27 1/2"D x 36"H (39 3/4"H to top of back splash)
Weight	266 lbs.
Shipping Weight	348.5 lbs.

General Properties	
Oven Capacity	4.2 cu. ft.
Cooking Modes – Main Cavity	Bake, Convection Bake, Broil
Cooking Modes – Second Cavity	N/A
Lighting	2 Long-lasting Halogen Bulbs
Cleaning Type	EasyClean™ Vitreous Enamel
Grate Type	Continuous Cast Iron
Controls	Die Cast Metal Knobs
Sealed Burners	Yes

Oven Performance	
Convection Bake Power	3,000 W top element/850 W bottom element
Bake Power	3,000 W top element/850 W bottom element
Broiler Power	3,500 W
Broiler Type	Tubular Wire

Cooktop Performance	
Number of Burners	4
Power of Front Left Burner BTU	15,000 Btu High 700 Btu Low
Power of Back Left Burner BTU	12,000 Btu High 2,800 Btu Low
Power of Front Center Burner BTU	N/A
Power of Back Center Burner BTU	N/A
Power of Front Right Burner BTU	15,000 Btu High 700 Btu Low
Power of Back Right Burner BTU	12,000 Btu High 2,800 Btu Low

Accessories Included	
1 - Porcelain enameled broiler pan with grid	3 - Oven racks
1 - Pan insert	LP Conversion Kit

Warranty

2 Years Warranty, Entire Appliance, Parts and Labor



(800) 223.3900

www.aga-ranges.com

AGA Professional

30" Dual Fuel Range with RapidBake Convection™

APRO30DFSS

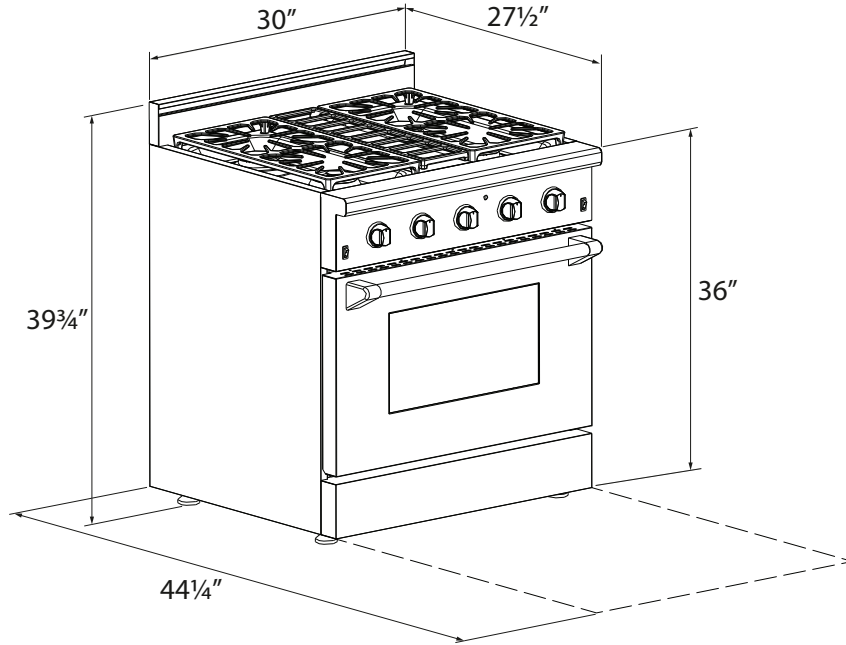

Standard Installation

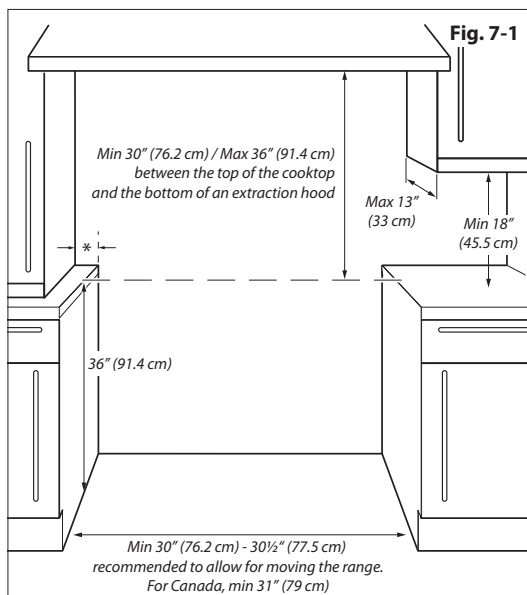

(800) 223.3900

www.aga-ranges.com