



Specifications

ABF 110DCMH-S G6 Series

MULTI-SPEED Continuous Run Bathroom Fan with Humidity and Motion Sensor

Description: Multi-speed quiet DC (Direct Current) bathroom fan with continuous adjustable CFM dial from a low of 0/50 CFM to a high of 110 CFM • Integrated user adjustable motion and humidity sensor • Ceiling mount • Suitable for new construction or remodeling • HVI certified • ENERGY STAR certified • ETL/cETL listed for use in insulated ceilings (Type I.C.).

Motor/Blower: Brushless high performance DC motor engineered for continuous energy efficient operation; power rating 120v/60Hz; motor equipped with thermal shut off.

Housing: Galvanized steel body; duct connector adapts to 4", 5" or 6", built-in back draft dampener; patented quick mounting anti-vibration bracket included; designed for installation in ceilings with minimum of 8" clearance.

Grille: Low maintenance, wipe clean; attaches to housing with torsion springs.

Finishes: White (W)

Ventilating Area: For bathrooms up to 110 sq ft.

Installation: Must be installed by licensed professional. Complete installation instructions included.

Warranty: 6 Years

Architect's Specifications: Multi-speed continuous run ventilation fan will be ceiling mount, ENERGY STAR qualified, adjustable speed of 50-80-110 CFM, with no less than 110 CFM and no more than 1.0 Sones as certified by HVI at 0.1 static pressure in inches water gauge. Power consumption shall be no greater than 16.0 watts and ENERGY STAR rated with an efficiency rating of no less than 7.0 CFM/watt. The motor will be enclosed brushes DC motor engineered for continuous operation. CFM switch tab will allow for 3 separate airflow (CFM) settings for 4", 5", or 6" duct. Fan will begin operation when humidity rises above user-adjusted setpoint. Adjustable timer. Fan shall be listed for tub/shower enclosure when used with GFCI branch circuit wiring and shall be ETL/cETL listed for use in insulated ceiling (Type I.C.). Fan shall be ASHRAE 62.2, LEED, California Title 24, and Washington VIAQ compliant.

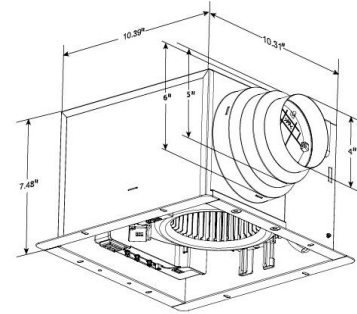

ETL/cETL Listed for installation over tub/shower enclosure when used with GFCI circuit wiring

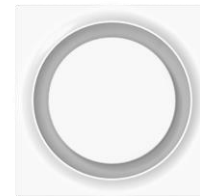

G6 (W) Grille

Model: ABF 110DCMH-S G6 Series	4" Duct	
Static Pressure (inches w.g.)	0.1	0.25
Air Volume (CFM)	112	95.6
Noise (sones)	1.0	1.2
Power Consumption (Watts)	16	17.5
Energy Efficiency (CFM/Watts)	7.0	5.5
Speed (RPM)	1159	N/A
ENERGY STAR rated	Yes	
Grille Dimensions	13" x 13"	



Model	Qty	Comments	Project
			Location
			Architect
			Engineer
			Contractor
			Submitted by
			Date