

ABF110DCMH G6 SERIES

DC Ventilation Fan with Motion & Humidity Sensor



Description:
Ultra quiet, DC Bathroom Fan with adjustable speed control from a low of 0/50CFM to 110 CFM. Includes an internal user adjustable humidity and motion sensor. Suitable for new construction or remodeling. Fan shall be ENERGY STAR qualified and HVI certified. ETL/cETL listed for use in insulated ceilings.(Type I.C.).

- Motor/Blower:**
- Brushless, high-performance DC Motor
 - Engineered for continuous operation.
 - Power rating shall be 120v/60Hz.
 - Fan shall be UL and cUL listed for tub/shower enclosure when GFCI protected.
 - Motor equipped with thermal shut-off.

- Housing:**
- Galvanized Steel Body
 - Duct connector adapts to 4", 5" and 6" ductwork.
 - Built-in damper
 - Articulating and expandable anti-vibration brackets included.
 - Designed for installation in ceilings with a minimum of 8" clearance.

Grille:
Low maintenance, attaches to housing with torsion springs. Round on square design.

Finishes: White (W) Only.

Ventilating Area:
For bathrooms up to 110 square feet.

Motion & Humidity Sensor:
Adjustable from 50% - 100% relative humidity. Responds to humidity level above a preset point or detected motion.

Warranty:
6 Years when installed by licensed professional.

Architectural Specifications:
Ventilation fan will be ceiling mount, ENERGY STAR qualified, adjustable speed (50/80/110CFM), with no less than 110CFM and no more than 1.0 sones as certified by HVI. Power consumption shall be no greater than 16.0 watts and ENERGY STAR rated with an efficiency rating of no less than 7.0 CFM/watt. Brushless DC motor will be permanently lubricated, engineered for continuous operation. CFM switch will allow for 3 separate CFM settings. Fan will start when humidity level rises above user set point or motion is detected. Adjustable timer. Duct diameter will be 4", 5" or 6" round. Fan shall be listed for tub/shower enclosure when used with GFCI branch circuit wiring and shall be ETL/cETL listed for use in insulated ceilings (Type I.C.). Fan shall be ASHRAE 62.2, LEED, California Title 24 and Washington VIAQ. compliant.

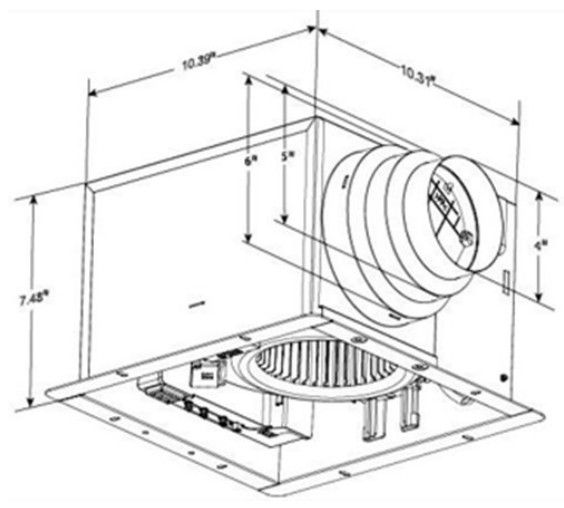

| Model: ABFDCMH Series | 4" Duct | |
|-------------------------------|-----------|------|
| Static Pressure (inches w.g.) | 0.1 | 0.25 |
| Air Volume (CFM) | 112 | 95.6 |
| Noise (Sones) | 1.0 | 1.2 |
| Power Consumption (Watts) | 16 | 17.5 |
| Energy Efficiency (CFM/Watts) | 7 | 5.5 |
| Speed (RPM) | 1159 | n/a |
| ENERGY STAR rated | YES | |
| Grille Dimensions | 13" x 13" | |



| Model | Qty | Comments | Project |
|-------|-----|----------|---------------|
| | | | Location |
| | | | Architect |
| | | | Engineer |
| | | | Contractor |
| | | | Submitted by: |
| | | | Date: |

813 Ridge Lake Blvd., Ste. 210 Memphis, TN 38120
 843.377.8642 www.aeropurefans.com