

ABFS0511 DL6 SERIES

Ultra Slim Fit DC Ventilation Fan with LED Light



Description:

Ultra Slim Fit, DC Bathroom Fan with adjustable speed control (50/80/110CFM). Fits 2x4 construction. 10W 3000K 850 Lumens dimmable LED light and 0.7W nightlight. Suitable for new construction or remodeling. Fan shall be ENERGY STAR qualified and certified by the Home Ventilating Institute (HVI). ETL/cETL listed for use in insulated ceilings (Type I.C.).

Motor/Blower:

- Brushless high-performance DC motor.
- Engineered for continuous operation.
- Power rating shall be 120v/60Hz.
- Fan shall be UL and cUL listed for tub/shower enclosure when GFCI protected.
- Motor equipped with thermal shut-off.

Housing:

- Galvanized Steel Body
- 4" oval duct connector
- Built-in backdraft damper
- Articulating and expandable anti-vibration brackets included.
- Designed for installation in ceilings with a minimum of 4" clearance.

Grille:

Low maintenance, attaches to housing with torsion springs. Round on square design.

Finishes: White (W)

Light: Energy Efficient dimmable 10W LED (3000K) with 0.7K night light.

Ventilating Area:

For bathrooms up to 110 square feet.

Warranty:

6 Years when installed by licensed professional.

Architectural Specifications:

Ventilation fan will be ceiling mount, ENERGY STAR qualified, adjustable speed of 50/80/110CFM with no less than 80CFM and no more than 0.4 Sones as certified by HVI at 0.1 static pressure in inches water gauge.

Power consumption shall be no greater than 7.4 watts and ENERGY STAR rated with an efficiency rating of no less than 10.9CFM/watt. The brushless DC motor will be permanently lubricated and engineered for continuous operation. Light shall be 10W 3000K LED and include 0.7W night-light. CFM switch will allow for separate CFM setting with a 4" diameter oval duct. Fan shall be listed for tub/shower enclosure when used with GFCI branch circuit wiring and shall be ETL/cETL listed for use in insulated ceilings (Type I.C.). Fan shall be ASHRAE 62.2, LEED, California Title 24 and Washington VIAQ compliant.

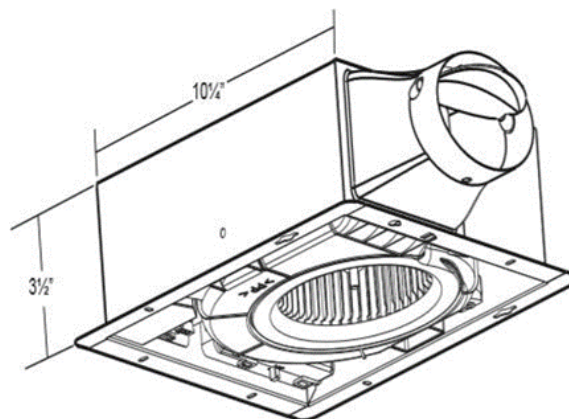

Model: ABFS0511 Series	4" Duct	
Static Pressure (inches w.g.)	0.1	0.25
Air Volume (CFM)	80	80
Noise (Sones)	0.4	0.9
Power Consumption (Watts)	7.4	11.5
Energy Efficiency (CFM/Watts)	10.9	7.0
Speed (RPM)	852	1100
ENERGY STAR rated	YES	
Grille Dimensions	13" x 13"	



Model	Qty	Comments	Project
			Location
			Architect
			Engineer
			Contractor
			Submitted by:
			Date:

813 Ridge Lake Blvd., Ste. 210 Memphis, TN 38120

843.377.8642

www.aeropurefans.com