

# ABF110DH L6 SERIES

## Ventilation Fan with LED Light & Humidity Sensor



### Description:

Ultra quiet, ceiling mount, DC Bathroom Fan with adjustable speed control from a low of 50-80-110CFM. 10W 3000K, 850 Lumens dimmable LED light and 0.7W nightlight. Includes an internal user adjustable humidity sensor. Suitable for new construction or remodeling. Fan shall be ENERGY STAR qualified and HVI certified. ETL/cETL listed for use in insulated ceilings.(Typel.C.).

### Motor/Blower:

- Brushless, high-performance DC Motor
- Engineered for continuous operation.
- Power rating shall be 120v/60Hz.
- Fan shall be UL and cUL listed for tub/shower enclosure when GFCI protected.
- Motor equipped with thermal shut-off.

### Housing:

- Galvanized Steel Body
- Duct connector adapts to 4", 5" and 6" ductwork.
- Built-in damper
- Articulating and expandable anti-vibration brackets included.
- Designed for installation in ceilings with a minimum of 8" clearance.

### Grille:

Low maintenance, attaches to housing with torsion springs. Round on square design.

**Finishes:** White (W)

**Light:** Energy-efficient dimmable 10W, 3000K LED with 0.7W nightlight.

### Ventilating Area:

For bathrooms up to 110 square feet.

### Humidity Sensor:

Adjustable from 50% - 100% relative humidity. Responds to humidity level above a preset point.

### Warranty:

6 Years if installed by licensed professional.

### Architectural Specifications:

Ventilation fan will be ceiling mount, ENERGY STAR qualified, with no less than 110CFM and no more than 0.9 Sones as certified by HVI at 0.1 static pressure in inches water gauge. Power consumption shall be no greater than 15.2 watts and ENERGY STAR rated with an efficiency rating of no less than 7.4CFM/watt. The DC motor will be brushless and engineered for continuous operation. CFM switch tab will allow for 3 separate airflow setting for duct diameter of 4", 5" or 6" round. Light shall be 10W, 3000K dimmable LED with 0.7W nightlight. Fan will start when humidity level rises above user setpoint. Fan shall be listed for tub/shower enclosure when used with GFCI branch circuit wiring and shall be ETL/cETL listed for use in insulated ceilings (Type I.C.). Fan shall be ASHRAE 62.2, LEED, California Title 24 and Washington VIAQ compliant.

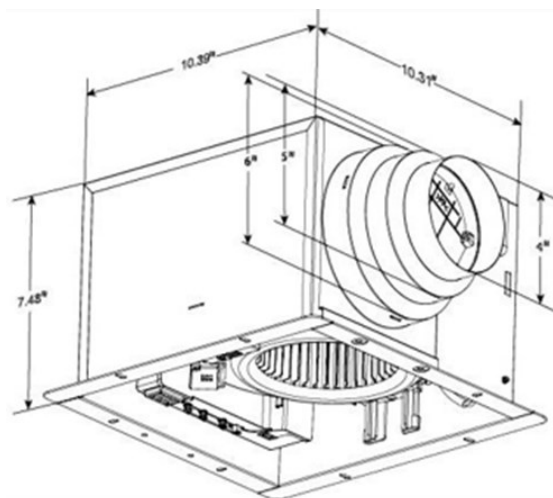

W

Model: ABF110DHL Series	4" Duct	
Static Pressure (inches w.g.)	0.1	0.25
Air Volume (CFM)	110	93.9
Noise (Sones)	0.9	1.2
Power Consumption (Watts)	15.2	16.7
Energy Efficiency (CFM/Watts)	7.4	5.6
Speed (RPM)	1095	n/a
ENERGY STAR rated	YES	
Grille Dimensions	13" x 13"	



Model	Qty	Comments	Project
			Location
			Architect
			Engineer
			Contractor
			Submitted by:
			Date: