

# ABF110 G15 SERIES

## Ventilation Fan



### Description:

Ventilating fan shall be low noise, ceiling mount engineered for continuous operation. Suitable for new construction or remodeling. Fan shall be ENERGY STAR qualified and certified by the Home Ventilating Institute (HVI). ETL/cETL listed for use in insulated ceilings (Type I.C.).

### Motor/Blower:

- Permanently lubricated high performance AC motor.
- Engineered for continuous operation.
- Power rating shall be 120v/60Hz.
- Fan shall be UL and cUL listed for tub/shower enclosure when GFCI protected.
- Motor equipped with thermal shut-off.

### Housing:

- Galvanized Steel Body
- Duct connector adapts to 4", 5" and 6" ductwork.
- Built-in damper
- Articulating and expandable anti-vibration brackets included.
- Designed for installation in ceilings with a minimum of 8" clearance.

### Grille:

Low maintenance, attaches to housing with torsion springs. Square on square design.

**Finishes:** White (W), Satin Nickel (SN), Satin Gold (SG), Oil Rubbed Bronze (OR), Farmhouse Black (FHB).

### Ventilating Area:

For bathrooms up to 110 square feet.

### Warranty:

6 Years when installed by licensed professional.

### Architectural Specifications:

Ventilation fan will be ceiling mount, ENERGY STAR qualified, with no less than 110CFM and no more than 1.1 Sones as certified by HVI at 0.1 static pressure in inches water gauge. Power consumption shall be no greater than 24.5 watts and ENERGY STAR rated with an efficiency rating of no less than 4.56 CFM/watt. The motor will be permanently lubricated, engineered for continuous operation. Duct diameter will be 4", 5" or 6" round. Fan shall be listed for tub/shower enclosure when used with GFCI branch circuit wiring and shall be ETL/cETL listed for use in insulated ceilings (Type I.C.). Fan shall be ASHRAE 62.2, LEED, California Title 24 and Washington VIAQ compliant.

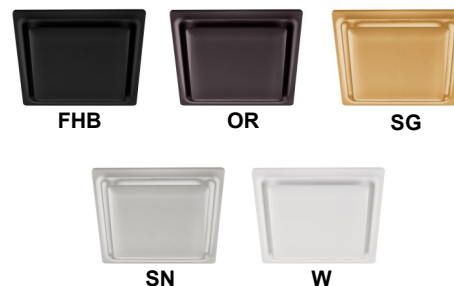
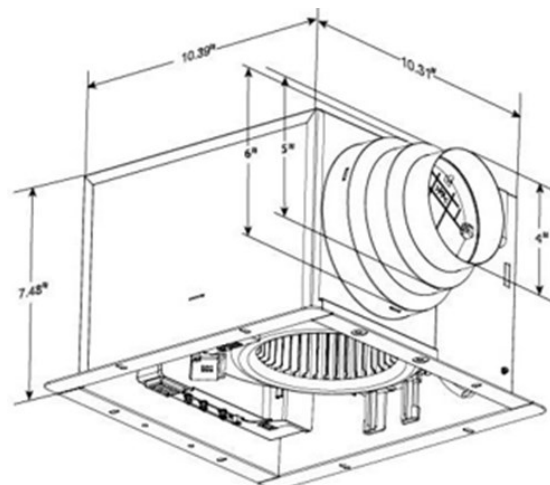

Model: ABF110 G15 Series	4" Duct	
Static Pressure (inches w.g.)	0.1	0.25
Air Volume (CFM)	110	87.7
Noise (Sones)	0.9	1.1
Power Consumption (Watts)	24.5	22.6
Energy Efficiency (CFM/Watts)	4.56	3.88
Speed (RPM)	1140	N/A
ENERGY STAR rated	YES	
Grille Dimensions	13" x 13"	



Model	Qty	Comments	Project
			Location
			Architect
			Engineer
			Contractor
			Submitted by:
			Date: