

# AP90H-SL SERIES

## Ventilation Fan with LED Light & Humidity Sensor



### Description:

Ultra Quiet, Slim Fit ventilating fan engineered for ceiling or wall mount continuous operation. Integrated humidity sensor is user adjustable. Suitable for new construction or re-modeling. Light source is a 10W, 3000K 1100 Lumens LED Light. ENERGY STAR qualified and HVI certified. ETL/cETL listed for use in insulated ceilings.(Typel.C.).

### Motor/Blower:

- Permanently lubricated high performance AC motor.
- Engineered for continuous operation.
- Power rating shall be 120v/60Hz.
- Fan shall be UL and cUL listed for tub/shower enclosure when GFCI protected.
- Motor equipped with thermal shut-off.

### Housing:

- 26 GA Galvanized Steel Body
- Detachable 4" & 6" Duct connector
- Built-in damper
- 2—24" expandable anti-vibration brackets included.
- Designed for installation in ceilings with a minimum of 6" clearance.

### Grille:

Contemporary design, wipes clean. Attaches to housing with torsion springs. Round on square design.

**Finishes:** White (W), Satin Nickel (SN), Satin Gold (SG), Oil Rubbed Bronze (OR), Farmhouse Black (FHB).

**Light:** Non-dimmable 10W, 3000K, 1150 Lumens LED Light Panel.

### Ventilating Area:

For bathrooms up to 90 square feet.

### Humidity Sensor:

Adjustable from 50% - 100% relative humidity. Responds to a rapid rise in humidity

### Warranty:

6 Years if installed by licensed professional.

### Architectural Specifications:

Ventilation fan will be ceiling or wall mount, ENERGY STAR qualified, with no less than 90CFM and no more than 0.3 Sones as certified by HVI at 0.1 static pressure in inches water gauge. Power consumption shall be no greater than 33 watts and ENERGY STAR rated with an efficiency rating of no less than 2.7 CFM/watt. The motor will be permanently lubricated, engineered for continuous operation. Light source shall be a 10W 3000K LED Light panel. Fan will start when relative humidity is above user set-point (50% - 100%). Duct diameter will be 4" or 6" round. Fan shall be listed for tub/shower enclosure when used with GFCI branch circuit wiring and shall be ETL/cETL listed for use in insulated ceilings (Type I.C.). Fan shall be ASHRAE 62.2, LEED, California Title 24 and Washington VIAQ compliant.

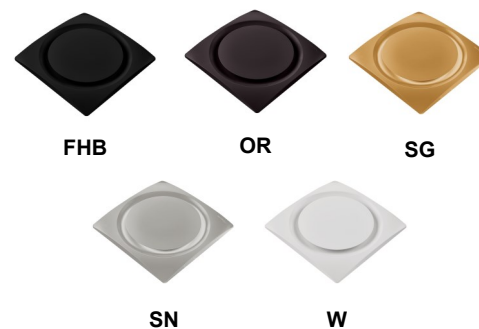
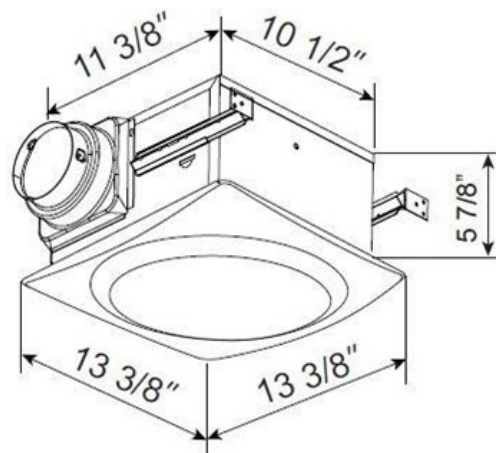

Model: AP90H Series	4" Duct	
Static Pressure (inches w.g.)	0.1	0.25
Air Volume (CFM)	90	68
Noise (Sones)	0.3	n/a
Power Consumption (Watts)	33	32.3
Energy Efficiency (CFM/Watts)	2.7	2.1
Current (Amps)	0.4	0.36
ENERGY STAR rated	YES	
Grille Dimensions	13 3/8" x 13 3/8"	



Model	Qty	Comments	Project
			Location
			Architect
			Engineer
			Contractor
			Submitted by:
			Date:

813 Ridge Lake Blvd., Ste. 210 Memphis, TN 38120

843.377.8642

www.aeropurefans.com