

A515A SERIES

2 Bulb Heater with Ventilation and Light



Description:

Ventilating fan shall be low noise, ceiling mount engineered for continuous operation. Suitable for new construction or remodeling. Conforms to UL/CUL safety standards with GFCI wiring. Includes 2 anti-blast infrared heat lamps and 60W incandescent bulb. 3 function wall switch included.

Motor/Blower:

- Permanently lubricated enclosed condenser motor.
- Engineered for continuous operation.
- Power rating shall be 120v/60Hz.
- Fan shall be UL and cUL listed when GFCI protected.
- Motor equipped with thermal shut-off.

Housing:

- Rust proof painted Steel Body
- 4" Duct connector
- Built-in damper
- Articulating and expandable anti-vibration brackets included.
- Designed for installation in ceilings with a minimum of 8" clearance.

Grille:

Low maintenance, attaches to housing with torsion springs.

Finishes: White (W).

Ventilating Area:

For bathrooms up to 80 square feet.

Warranty:

6 Years when installed by licensed professional.

Architectural Specifications:

Exhaust fan will be ceiling mount with no less than 80CFM and no more than 1.0 Sones at 0.1 static pressure in inches water gauge. Power consumption shall be no greater than 610 watts. The motor will be permanently lubricated, engineered for continuous operation. Duct diameter will be 4" round. Exhaust fan, heater and light may be wired separately. Fan will not be installed directly over tub/shower enclosure. When used with GFCI branch circuit wiring shall be UL/CUL listed for use in insulated ceilings (Type I.C.).

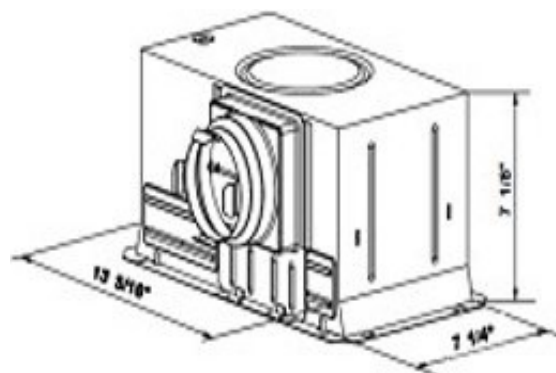

W

Model: A515A Series	4" Duct
Static Pressure (inches w.g.)	0.1
Air Volume (CFM)	80
Noise (Sones)	1
Power Consumption (Watts)	610
Current (Amps)	5.1
Housing Dimensions	7 1/4" x 7 1/8" x 13 3/16"
Grille Dimensions	9 1/16" x 15 3/4"



Model	Qty	Comments	Project
			Location
			Architect
			Engineer
			Contractor
			Submitted by:
			Date: