

CATALOG NUMBER	TYPE
PROJECT	

DECORATIVE WALL SCONCE

MODEL WS54-G513AM

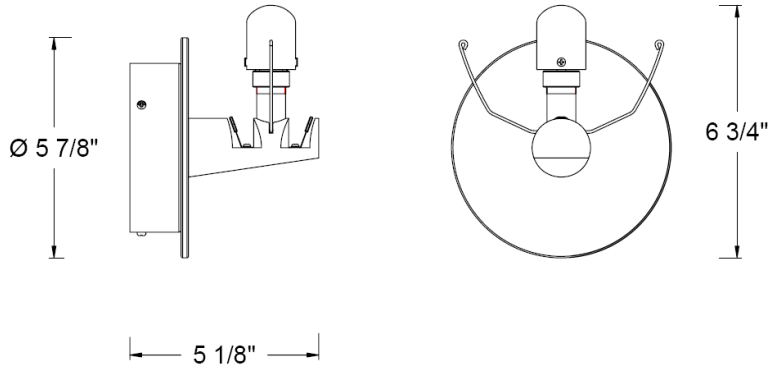

Ordering Matrix

Model Number	Shade	Sconce Finishes	
WS54	G513AM	BN	CH

Ordering Example (*model number – shade/ sconce finishes*): WS54-G513AM/BN

Product Details

Description:	Low voltage wall sconce with round finished metal front fascia. The sconce is made of brass, with a plated Chrome or Brushed Nickel finish and a ceramic bi pin socket with screw-on etched bulb shield. Mounting canopy includes an integral electronic transformer.
Mounting:	Surface mounted. Installs to a standard 4" junction box.
Lamping	12V 50w halogen bi-pin included.
Transformer:	Integral Electronic Low Voltage Transformer. 120v/60hz input.
Sconce Finish:	CH = Chrome BN = Brushed Nickel
Shade:	Ella – G513 Ella's soft profile and appealing hues are the stars of this show. The casing inside these charming shades provides a warm, natural white light that will illuminate any space beautiful.
Listing:	UL & CUL Listed.

Specification Features

- Dimmable with low voltage electronic dimmers.
- The screw-on bulb shield retains the glass shade and protects the lamp from dust and fingerprints.
- The wall sconce is available in multiple standard glass shade styles and multiple color options
- WAC electronic low voltage transformer includes auto reset, short and overload protection features. Transformer Soft Start® delayed start feature extends lamp life by limiting abrupt inrush current to the lamp.
- 5 year WAC Lighting product warranty.