

CATALOG NUMBER	TYPE
PROJECT	

5" PREMIUM DOWNLIGHT TRIM **R5VT-25**

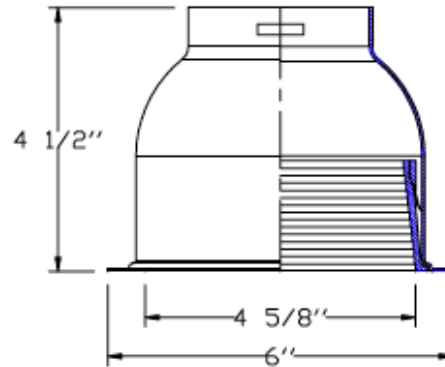

Ordering Matrix		
Series	Model Number	Finish
[]	[]	[]
R5VT	25	WT

Ordering Example (series – model number – finish): R5VT-25-WT

Product Details	Specification Features
<p>Application: Ceiling down light trim, 1-inch maximum ceiling thickness. Provides smooth broad area illumination without shadows. Used with incandescent or fluorescent lamp housings.</p> <p>Materials: One-piece spun aluminum construction. Integral trim ring is painted white, interior reflector is anodized aluminum. Trim is retained to socket via spring clips.</p> <p>Finish: WT = White baffle with White trim</p> <p>Ratings: UL & CUL listed.</p>	<ul style="list-style-type: none"> • Suitable for damp locations • 5 year WAC Lighting product warranty.

Compatible Housings (sold separately)					
<p>R5VI-ICA Insulation Contact & Air Tight New Construction Incandescent Lamp: PAR38 50W</p>		<p>R5VI-R-ICA Insulation Contact & Air Tight Remodeling Incandescent Lamp: A19 40W PAR30 50W</p>		<p>R5VI Non IC Frame-in Style New Construction Incandescent Lamp: A19 75W PAR30 75W</p>	
<p>R5VI-S-ICA Insulation Contact & Air Tight Shallow New Construction Incandescent Lamp: PAR30 50W</p>		<p>R5VI-S-R-ICA Insulation Contact & Air Tight Shallow Remodeling Incandescent Lamp: PAR30 50W</p>		<p>R5VF-113Q Non IC Frame-in Style New Construction Fluorescent Lamp: Quad 13W G24Q-1</p>	

CATALOG NUMBER	TYPE
PROJECT	

5" PREMIUM DOWNLIGHT TRIM R5VT-25

<p> R5VF-126/32T Non IC Frame-in Style New Construction Incandescent Lamp: Tri-tube 26/32W GX24Q-3 </p>	
--	---

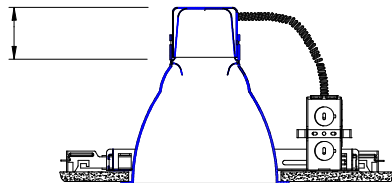

Socket cup adds a maximum of 2 1/8" to the height of the trim when used with frame in kits.