

Type _____
-28
P9217

Catalog No.	Finish White	Lamping	Dimensions (Inches)			
			A	B	C	D
P9217	-28	3-50w MR16	48	2-1/8	5-1/4	5-1/4

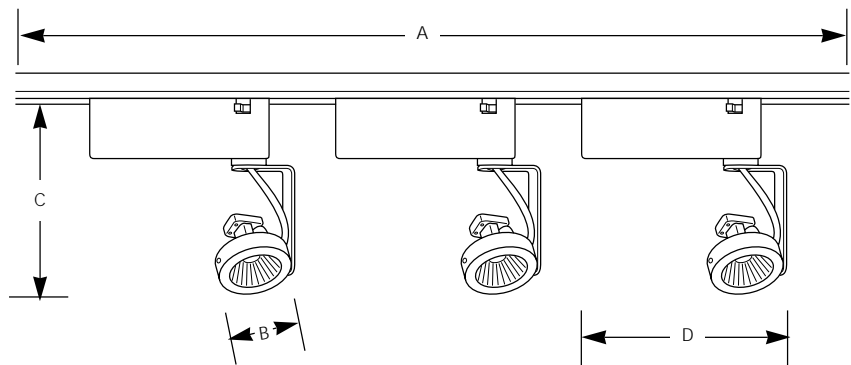

Specifications:

Track Kit Contents

- Four feet of track, dead ends, feed, canopy and mounting hardware
- Three track heads
- "Anywhere" line feed

Track

- Extruded aluminum
- Polarity notch
- Keyhole and round knockouts on top for mounting
- 120-volt, 20-amp capacity
- Flat buss bars

Track Head Lock Ups

- Polarity oriented
- Quarter-turn locking action
- Tab lock to track to prevent accidental removal

Track Heads

- 50-watt electronic transformer attaches to track
- High-tech MR16 lamp holder connects to transformer
- Adjustable in any direction

Labeling

- UL-CUL dry location listed

Photometrics

- Refer to MR16 Lamp Application Data

MR16 Lamp Application Data

Figure 1
Single lampholder

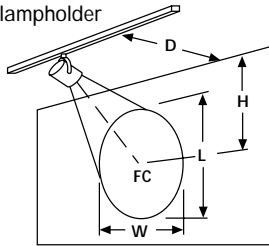
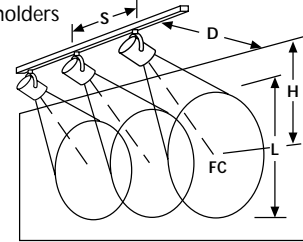

Figure 2
Multiple lampholders



MR16
Flood Lamps



Walls and Vertical Objects													Horizontal Surfaces			
H	F.C.	L	W	S	F.C.	L	W	S	F.C.	L	W	S	Clg. Ht.	F.C.	Dia. & Spacing	
D = 2 FT				D = 3 FT				D = 4 FT								
35MR16FL	2	88	3.4	2.1	1.8	64	3.4	2.6	2.2	45	3.8	3.3	2.8	8	33	3.8
CBCP - 1,000	3	43	6.7	2.6	2.2	39	5.0	3.1	2.6	32	4.9	3.6	3.1	9	24	4.4
Beam - 40 deg.	4	22	15.4	3.3	2.8	24	7.9	3.6	3.1	22	6.7	4.1	3.5	10	18	5.1
50MR16NFL	3	137	3.2	1.6	1.5	126	2.8	1.9	1.8	102	2.9	2.2	2.1	8	106	2.4
CBCP - 3,200	4	72	5.5	2.0	1.9	77	4.0	2.2	2.1	71	3.7	2.5	2.3	9	76	2.8
Beam - 25 deg.	5	41	9.3	2.4	2.2	48	5.8	2.6	2.4	49	4.9	2.8	2.7	10	57	3.2
50MR16FL	3	73	6.7	2.6	2.2	67	5.0	3.1	2.6	54	4.9	3.6	3.1	8	56	3.8
CBCP - 1,700	4	38	15.4	3.3	2.8	41	7.9	3.6	3.1	38	6.7	4.1	3.5	9	40	4.4
Beam - 40 deg.	5	22	61.4	3.9	3.4	26	13.1	4.2	3.6	26	9.4	4.7	4.0	10	30	5.1

MR16
Spot Lamps



Walls and Vertical Objects													Horizontal Surfaces			
H	F.C.	L	W	S	F.C.	L	W	S	F.C.	L	W	S	Clg. Ht.	F.C.	Dia. & Spacing	
D = 2 FT				D = 3 FT				D = 4 FT								
35MR16SP	3	167	2.5	1.3	1.2	153	2.2	1.5	1.4	125	2.2	1.8	1.7	8	129	1.9
CBCP - 3,900	4	88	4.0	1.6	1.5	94	3.1	1.8	1.7	86	2.9	2.0	1.9	9	92	2.3
Beam - 20 deg.	5	50	6.3	1.9	1.8	59	4.4	2.1	2.0	60	3.8	2.3	2.2	10	69	2.6
Walls and Vertical Objects													Horizontal Surfaces			
H	F.C.	L	W	S	F.C.	L	W	S	F.C.	L	W	S	Clg. Ht.	F.C.	Dia. & Spacing	
D = 3 FT				D = 4 FT				D = 5 FT								
50MR16NSP	4	219	2.3	1.3	1.3	201	2.1	1.5	1.5	173	2.2	1.7	1.6	10	162	20
CBCP - 9,100	6	91	4.2	1.8	1.7	97	3.6	1.9	1.9	107	3.0	2.0	1.9	14	69	3.0
Beams - 15 deg.	8	44	7.3	2.2	2.2	51	5.6	2.4	2.3	54	4.9	2.5	2.4	18	38	4.0

Walls and Vertical Objects

H	Height from ceiling to center of beam
D	Distance from fixture to wall
F.C.	Footcandles at center of beam
L	Length of effective lighted area
W	Width of effective lighted area
S	Spacing of multiple fixtures to effectively light wall

Horizontal Surfaces

Clg. Ht.	Height from floor to ceiling
F.C.	Footcandles 30" from floor (work plane)
Dia. & Spacing	Diameter of effective lighted area and spacing to effectively light the horizontal surface

CBCP - Center Beam Candlepower