

ASSEMBLY AND INSTALLATION INSTRUCTIONS - IMPORTANT! GENERAL INSTRUCTIONS - READ THIS PAGE FIRST.

- 1) Read and understand all instructions completely, both front and back before proceeding with assembly and installation of this fixture.
- 2) If you have doubts about how to install a lighting fixture or if fixture fails to operate correctly, please contact a local qualified licensed electrical contractor.
- 3) Before you start:
 - a) NEVER attempt to do any work without shutting off the electricity until the work is complete. Go to the main fuse box in your home. Place main power switch to "off" position.
 - b) Unscrew the fuse or fuses that control the power to the fixture or room that you are working on.
 - c) Turn fixture to be replaced off. Place wall switch in off position. If fixture to be replaced has built in switch or pull chain, place those in off position.
- 4) All parts must be used as indicated in the assembly/installation instructions. Do not substitute any other parts, leave any parts out, or use any parts which are worn out or broken. Failure to obey this instruction could invalidate the U.L. listing and/or C.S.A. certification of this fixture.
- 5) Be sure to use light bulbs with wattage no greater than specified on this fixture. Be certain electric current is turned off before changing bulb.
- 6) If a green insulated wire or bare copper or silver wire is included with this fixture be certain never to attach this wire to the "hot" current carrying supply wire.
- 7) If parts need to be replaced use only authorized replacement parts. Write to Authorized Replacement Parts Distribution Dept., P.O. Box 318010, Cleveland, Ohio 44131-8010
- 8) Be sure fixture is supported only by chain.(if fixture hangs by chain) and not by wire.
- 9) Keep this sheet in a safe place and review it before doing any work on this fixture.

The hand-crafted beauty of this fixture is the result of tasteful design, experienced engineering, careful craftsmanship and a dedication to customer satisfaction.

You will be assured years of service and enjoyment if you read and observe the following list of product care suggestions:

- Be certain electric current is turned off before cleaning.
- Clean metal components with a soft cloth, moistened with a mild liquid soap solution. Wipe clean and buff with a soft dry cloth. Under no circumstances should any metal polish be used, as its abrasive nature could damage the protective finish placed on the metal parts.
- Wood components may be polished with a fine furniture polish, taking care to avoid getting the polish on the metal surfaces.
- Never wash glass shades in an automatic dishwasher. To wash glass shades, line a sink with a towel and fill with warm water and a mild liquid soap. Wash glass with a soft cloth, rinse and wipe dry.

INSTRUCCIONES DE MONTAJE E INSTALACIÓN - INSTRUCCIONES GENERALES IMPORTANTES - LEA ESTA PÁGINA PRIMERO.

- 1) Lea y entienda completamente todas las instrucciones, tanto del frente como del dorso antes de proseguir con el montaje e instalación de este artefacto.
- 2) Si tuviera alguna duda acerca de cómo instalar un artefacto luminoso o si el artefacto fallara en funcionar correctamente, por favor comuníquese con un contratista eléctrico licenciado calificado local.
- 3) Antes de comenzar:
 - a) NUNCA intente hacer un trabajo antes de apagar la alimentación eléctrica hasta que el trabajo esté terminado. Vaya a la caja principal de fisibles de la casa. Ponga el interruptor principal de corriente en posición "apagado".
 - b) Destornille el fusible o fusibles que controlen la alimentación eléctrica al artefacto o al cuarto donde está trabajando usted.
 - c) Apague el artefacto que va a reemplazar. Ponga el interruptor de pared en posición apagado. Si el artefacto que va a reemplazar tiene incorporado un interruptor o cadenilla de tiro, póngalos en posición apagado.
- 4) Todas las piezas se deben usar como se indica en las instrucciones de instalación / montaje. No substituya ninguna de las otras piezas, ni deje afuera las piezas o use piezas que estén desgastadas o rotas. La falla de obedecer esta instrucción podría invalidar el listado de UL y/o la certificación C.S.A. de este artefacto.
- 5) Asegúrese de usar las bombillas con el vatiaje no mayor que el especificado en este artefacto. Asegúrese de que la corriente eléctrica está apagada antes de cambiar la bombilla.
- 6) Si un cable aislado verde o cable de cobre desnudo o cable de plata se incluye con este artefacto, asegúrese de que nunca se acople este alambre al cable de alimentación eléctrica "vivo" que trae corriente.
- 7) Si es necesario cambiar piezas, use solamente piezas de reemplazo autorizadas. Escriba al Departamento de distribución de piezas de reemplazo autorizadas, P.O. Box 318010, Cleveland, Ohio 44131-8010.
- 8) Asegúrese de que el artefacto esté soportado solamente por la cadena (si el artefacto cuelga de la cadena) y no del cable.
- 9) Guarde esta hoja en un lugar seguro y examínela antes de hacer ningún trabajo en este artefacto.

La belleza de la artesanía manual de este artefacto es el resultado de un diseño de buen gusto, ingeniería experimentada, artesanía cuidadosa y la dedicación de satisfacción al cliente. Usted tendrá años de servicio y de gozo si lee y observa la lista siguiente con las sugerencias de cuidado del producto.

- Asegúrese de que la alimentación de corriente eléctrica esté apagada antes de limpiar.
- Limpie los componentes metálicos con una tela suave, humedecida en una solución de jabón líquido suave. Limpie y lustre con una tela seca y suave. Las partes metálicas no deben pulirse con pasta para pulir metales bajo ninguna circunstancia puesto que la naturaleza abrasiva de la pasta podría dañar el acabado protector de las partes metálicas.
- Los componentes de madera se pueden pulir con un compuesto fino de pulir muebles, teniendo cuidado de evitar pulir las superficies metálicas.
- Nunca lave las pantallas de vidrio en un lavaplatos automático. Para lavar las pantallas de vidrio, ponga una toalla como revestimiento de la piletta y llene de agua tibia y un jabón líquido suave. Lave el vidrio con una tela suave, enjuague y seque bien.

INSTRUCTIONS POUR LE MONTAGE ET L'INSTALLATION - IMPORTANT - INSTRUCTIONS GÉNÉRALES - LISEZ D'ABORD CETTE PAGE

- 1) Lisez attentivement et complètement toutes les directives qui figurent devant et derrière avant de procéder au montage et à l'installation de ce luminaire.
- 2) En cas d'hésitation sur la manière d'installer un luminaire ou si le luminaire ne fonctionne pas correctement, veuillez vous adresser à un électricien qualifié et agréé local.
- 3) Avant de commencer l'installation :
 - a) N'entrez JAMAIS l'installation avant d'avoir coupé le courant électrique et ce jusqu'à ce que l'installation soit terminée. Pour ce faire, mettez l'interrupteur principal de la boîte de fusibles sur la position « Arrêt ».
 - b) Dévissez le ou les fusibles qui contrôlent l'alimentation du luminaire ou celle de la pièce dans laquelle vous travaillez.
 - c) Éteignez le luminaire qui doit être remplacé. Mettez l'interrupteur mural sur la position « Arrêt ». Si le luminaire devant être remplacé est muni d'un interrupteur intégré ou à chaînette, mettez-les sur la position « Arrêt ».
- 4) Toutes les pièces doivent être utilisées comme indiqué dans les instructions de montage ou d'installation. Aucune pièce ne doit être remplacée ou inutilisée et aucune pièce endommagée ou usée ne doit être utilisée. Ne pas se conformer à cette directive peut annuler l'homologation UL et/ou la certification ACNOR du luminaire.
- 5) Veillez à utiliser des ampoules dont la puissance en watts n'est pas supérieure à celle indiquée sur le luminaire. Vérifiez que le courant électrique est coupé avant de changer une ampoule.
- 6) Si le fil vert isolé ou le conducteur en cuivre nu ou le fil argent sont inclus dans ce luminaire, veillez à ne jamais fixer ce fil au fil d'alimentation sous tension.
- 7) Pour obtenir des pièces de remplacement, adressez-vous à Authorized Replacement Parts Distribution Dept., P.O. Box 318010, Cleveland, Ohio 44131-8010.
- 8) Assurez-vous que le luminaire est supporté uniquement par une chaîne (si le luminaire est suspendu à une chaîne) et non par un fil électrique.
- 9) Conserver ce feuillet et lisez-le avant d'entreprendre tout travail sur ce luminaire.

Ce très beau luminaire, fabriqué à la main, est le résultat du bon goût, du savoir-faire, du travail soigné et de la recherche de la satisfaction de la clientèle.

Il vous assurera des années de service et de plaisir si vous suivez les conseils d'entretien suivants :

- Assurez-vous que le courant électrique est coupé avant de le nettoyer.
- Nettoyez les éléments en métal avec un chiffon doux imprégné d'une solution à base de savon liquide doux. Faites briller avec un chiffon sec et doux. N'utilisez jamais de produits pour polir les métaux. Abrasifs, ils risqueraient d'endommager le fini protecteur des pièces métalliques.
- Les éléments en bois doivent être lustrés avec de la cire pour meubles de bonne qualité. Ne mettez pas de cire sur les surfaces métalliques.
- Ne mettez jamais les abat-jour en verre dans un lave-vaisselle. Pour les laver, recouvrez le fond de l'évier avec une serviette. Remplissez l'évier d'eau chaude et ajoutez un savon liquide doux. Utilisez un chiffon doux, rincez et essuyez.

MEANS OF SUPPORT MUST BE ERECTED ABOVE OUTLET BOX. BELOW IS ONE SUGGESTED METHOD FOR JOIST 16" ON CENTER WITH FIXTURE CENTERED BETWEEN JOISTS, AS SHOWN

- 1) To erect means of support four pieces of lumber will be required (not included). Two 2x4's at min. of 19" long. Two 1x4's at min. 9 1/4" long.
- 2) Lay one 2x4 on flat surface suitable and stable for nailing.
- 3) Lay the two 1x4's on 2x4 allowing 1/2" gap between ends of 1x4's at center.
- 4) Lay remaining 2x4 on top of 1x4's and nail pieces together using 3 1/8" long 12d nails (not included) on center at approximately 3" from each end.
- 5) Turn assembled lumber over and nail two more nails in at approximately 6" from each end.
- 6) Turn off power.
- 7) If fixture is provided with a safety cable it must pass through outlet box. Drill 3/16" diameter hole in outlet box if no other holes are available.
- 8) Remove knockout in top of outlet box.
- 9) Align hole in mounting strap (D) with gap between 1x4's and secure to 2x4's using provided #10 sheet metal screws (Z).
- 10) In area above outlet box lay assembled lumber from steps 1-5 over ceiling joist (with mounting strap down) aligning gap between 1x4's with knockout removed in outlet box.
- 11) Screw hexnut (H) onto threaded rod (P).
- 12) Slip ground lug (F) and lockwasher (J) onto threaded rod (P).
- 13) Thread screw collar loop (L) onto threaded rod (P) until threaded pipe is flush with hole on lower side of screw collar loop or threaded rod bottoms out.
- 14) Secure screw collar loop (L) in place by tightening hexnut (H) down against ground lug (F), lockwasher (J) and screw collar loop.
- 15) Temporarily slip canopy (M) over screw collar loop (L). Approximately one half of the screw collar loop exterior threads should be exposed below canopy.
- 16) Temporarily screw threaded ring (N) onto screw collar loop (L).
- 17) In area above outlet box pull up on threaded rod (P) until canopy is snug against ceiling.
- 18) Slide flat washers (X) down threaded rod and against top of lumber assembly. Secure in place by running jam nuts (Q & R) down against flat washer.
- 19) Secure lumber assembly in place by toe-nailing or other means.
- 20) Tighten anti-rotational screw located next to center hole inside mounting strap (D) with provided wrench.
- 21) Remove threaded ring (N) and canopy (M).

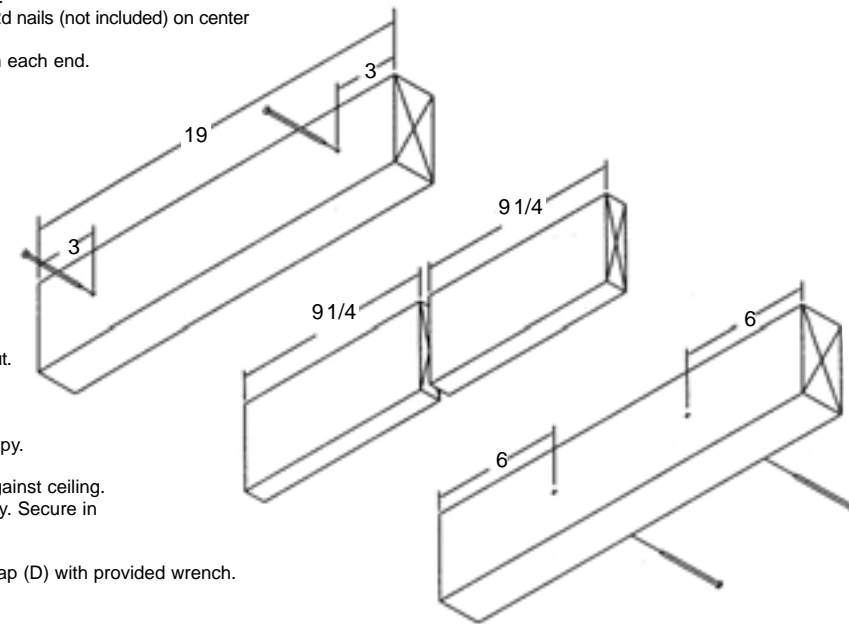

WARNING: TO ENSURE PERSONAL SAFETY AND TO PREVENT DAMAGE TO YOUR HOME CONSULT A QUALIFIED BUILDER OR ARCHITECT BEFORE INSTALLING A FIXTURE HEAVIER THAN 50 LBS. TO THE JOIST OR TRUSS SYSTEM OF YOUR HOME.

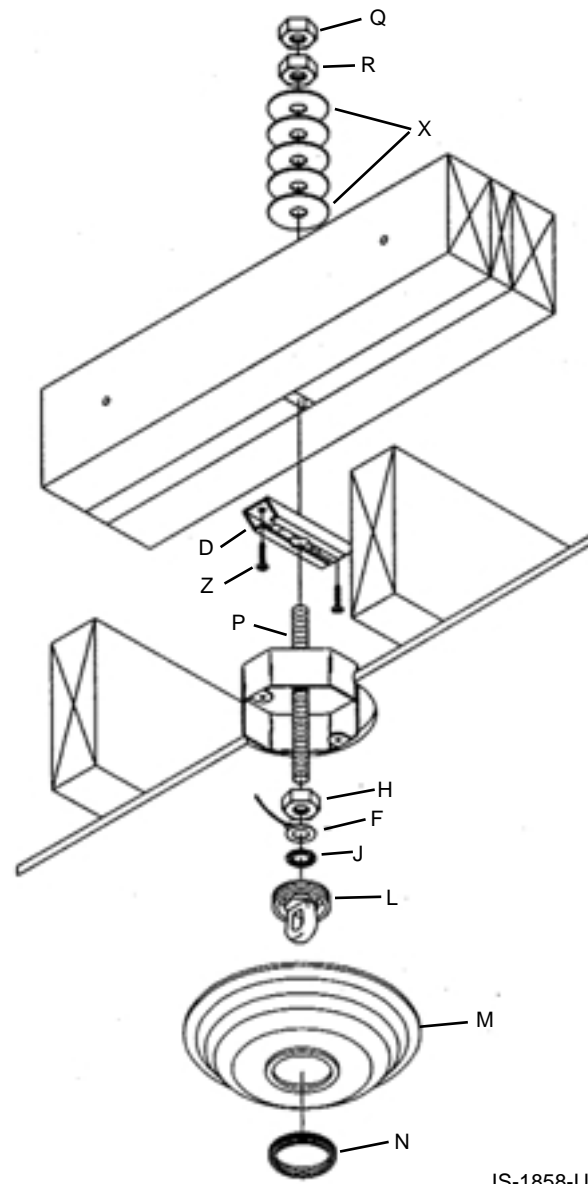

- 1) Rotate arms until in line with center of fixture body. Arms should tighten as they are turned. If arms are still loose tighten hexnuts inside fixture body.
- 2) Screw top body assembly to coupling at top of fixture body.
- 3) Align hole in bottom arm with hole at bottom of fixture body.
- 4) Secure arm in place with ball stud.
- 5) Screw bottom trim to bottom of fixture body.

For ease in assembly, proceed to section 3. Remaining steps in fixture assembly can be completed easier with fixture hanging.

- 6) Slip glass over socket. Secure in place with spacer and socket ring.

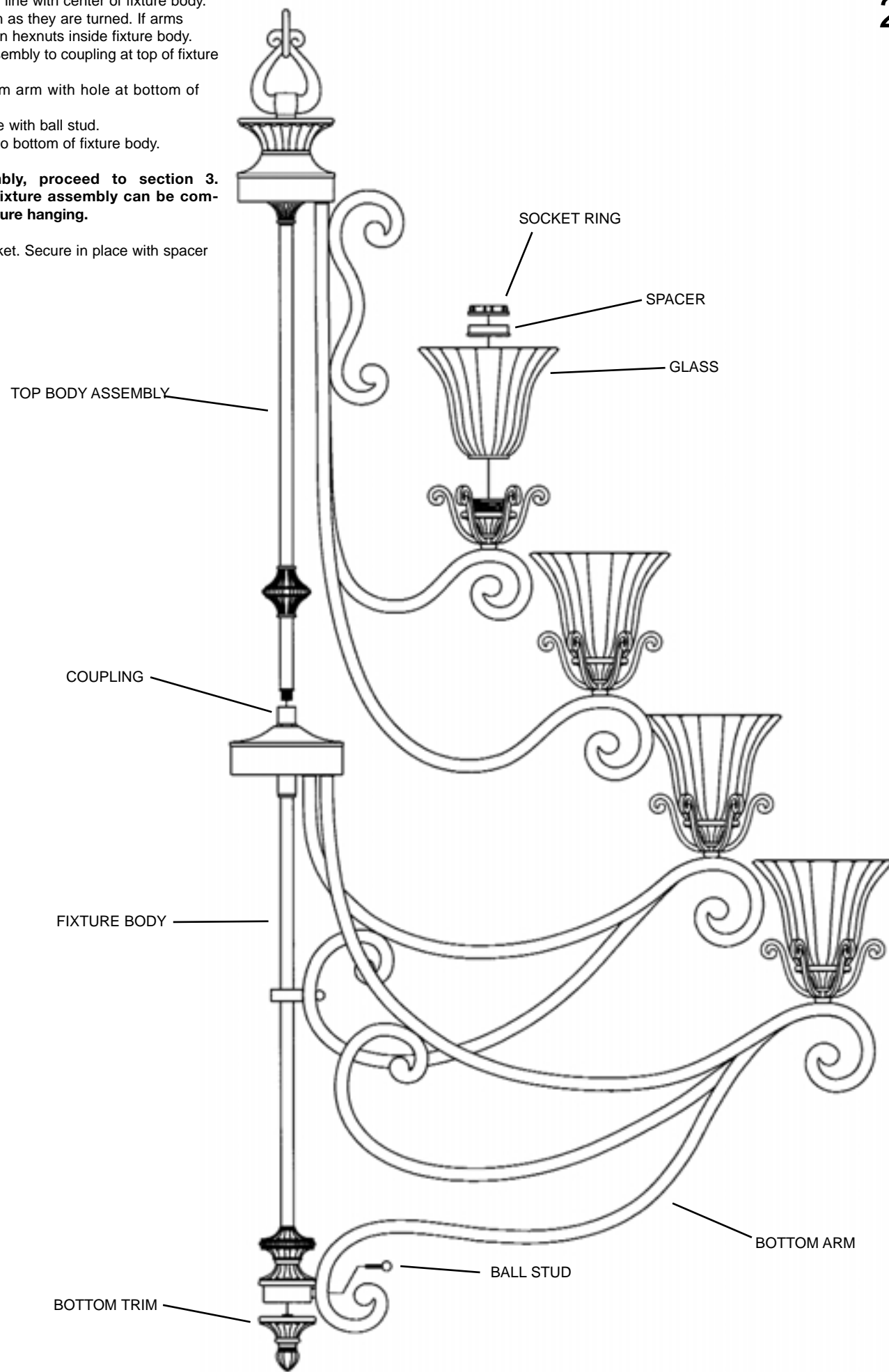

2

- 1) Attach chain to fixture. Fixture loop has one chain link factory installed. Chain has one locking link at each end. Unscrew coupling on locking link and slip over link attached to loop. Screw coupling closed.
- 2) Slip threaded ring (N) then canopy (M) onto chain (W)
- 3) Attach chain (with fixture connected) to bottom of screw collar loop following the same procedure as in step 1.
- 4) Weave electrical wire, ground wire and safety cable through chain links no more than 3 inches apart.
- 5) Pass electrical wire ground wire and safety cable through threaded ring (N), canopy (M), one of the slots in screw collar loop (L) and into outlet box.
- 6) Pass safety cable through hole (See sec. 1)
- 7) In area above outlet box wrap cable around one of the 2 x 4's erected in section 1 and pull cable taut..
- 8) Secure cable with (2) clamps provided.
- NOTE: Cable is not to be used as the only means of fixture support. Please follow independent mounting instructions completely.
- 8) Connect fixture ground wire and ground wire attached to threaded rod (B or P) to outlet box ground wire with wire connector (not provided). Never connect ground wire to black or white power supply wires.
- 10) Make wire connections (connectors not provided). Reference chart below for correct connections and wire accordingly.

Connect Black or Red Supply Wire to:	Connect White Supply Wire to:
Black	White
*Parallel cord (round & smooth)	*Parallel cord (square & ridged)
Clear, Brown, Gold or Black without tracer	Clear, Brown, Gold or Black with tracer
Insulated wire (other than green) with copper conductor	Insulated wire (other than green) with silver conductor

*Note: When parallel wires (SPT I & SPT II) are used. The neutral wire is square shaped or ridged and the other wire will be round in shape or smooth (see illus.)

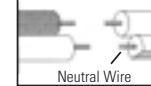

- 11) Raise canopy (M) to ceiling.
- 12) Secure canopy (M) in place by screwing threaded ring (N) onto screw collar loop (L)

3

