

Specification Sheet

Pendant

Models: **F1924-36 Satin Nickel**
F1924-68 Deep Bronze

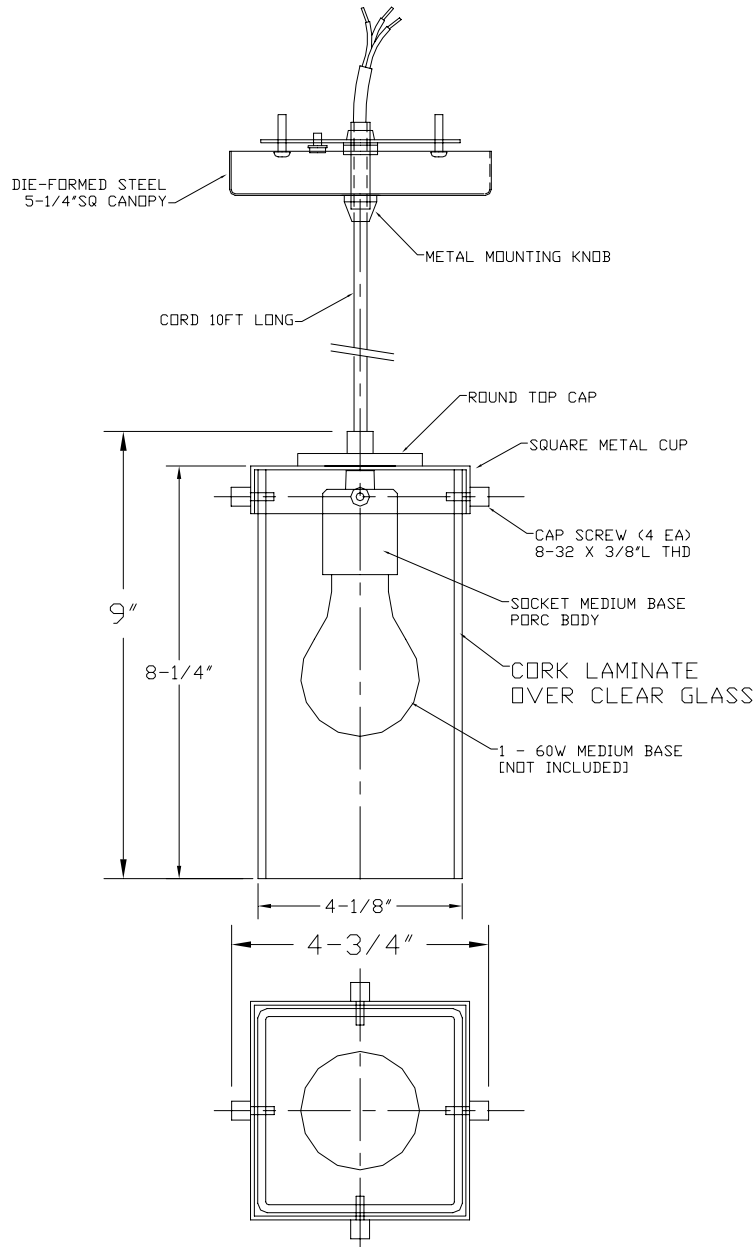

Glass: Cork Laminate Over Clear Glass
 Finishes: Satin Nickel -36 with Clear Silver Cord
 Deep Bronze -68 with Bronze Cord
 Width: 4-3/4" Height: 9" Overall Height: 129"
 Lamps: 1 - 60W Medium Base (Not Included)
 Labels: cULus Listed. Suitable for Dry Locations.