

INSTALLATION AND WIRING DIAGRAM

LEDRA® SERIES LEDS

LEDRA® PLUG-IN FLEX 2

ART. NO.	135 783bz/m	bronze, white, 30° lens
	135 783mc/m	matte chrome, white, 30° lens
	135 783-lbz/m	bronze, warm white, 30° lens
	135 783-lmc/m	matte chrome warm white, 30° lens

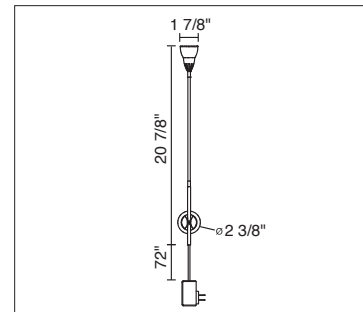

IMPORTANT SAFETY INSTRUCTIONS



1. INSTRUCTIONS PERTAINING TO A RISK OF FIRE, ELECTRIC SHOCK, OR INJURY TO PERSONS. DRY LOCATIONS ONLY.
2. Lighted lamp is HOT!
3. THIS PRODUCT MUST BE INSTALLED BY A PERSON FAMILIAR WITH THE CONSTRUCTION AND OPERATION OF THE PRODUCT AND THE HAZARDS INVOLVED, IN ACCORDANCE WITH THE APPLICABLE INSTALLATION CODE.
4. INVOLVED, IN ACCORDANCE WITH THE APPLICABLE INSTALLATION CODE.
5. Warranty is void in case of unauthorized modifications and/ or improper use.
6. SAVE THESE INSTRUCTIONS.

READ ALL OF THESE INSTALLATION INSTRUCTIONS BEFORE INSTALLING THE FIXTURE

Contents of Delivery:

LEDRA® PLUG-IN FLEX 2 - qty. (1)

WARNING

To reduce the risk of FIRE, ELECTRIC SHOCK, OR INJURY TO PERSONS:

- Lamp not replaceable
- Bulb (lamp) gets HOT quickly! Only contact plug when turning on.
- Do not touch hot lens, guard, or enclosure.
- Do not look directly at lighted bulb (lamp).
- Keep lamp away from materials that may burn.
- Use only with a 3 Watt or smaller bulb.
- Do not touch the bulb (lamp) at any time.

Step 1.

Installation instructions indicating proper means of mounting the lamp.

- Screw back plate (A) into mounting surface.
- Screw (B) fixture onto back plate
- Finally plug (D) fixture into wall socket, adjust fixture (C) to desired direction.

