

INSTALLATION INSTRUCTIONS

V/A

V/A KIT 150

ART. NO.	360 159bz	bronze, 150W Max
	360 159ch	chrome, 150W Max
	360 159mc	matte chrome, 150W Max

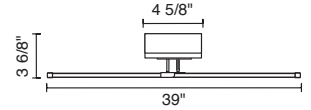

IMPORTANT SAFETY INSTRUCTIONS



1. Read all of these installation Instructions before installing the track system.
2. Save these instructions and refer to them when additions to or changes in the track configuration are made.
3. THIS PRODUCT MUST BE INSTALLED BY A PERSON FAMILIAR WITH THE CONSTRUCTION AND OPERATION OF THE PRODUCT AND THE HAZARDS INVOLVED, IN ACCORDANCE WITH LOCAL NEC CODE.
4. FOR USE WITH V/A NETWORK ONLY.
5. Do not install the track or any part which contains exposed wires less than 7 feet from the floor.
6. Do not install this rail in damp or wet locations.
7. Do not install fixture assembly closer than 6 inches from any curtain, or similar combustible material.
8. Disconnect electrical power before adding to or changing the configuration of the track.
9. Do not attempt to energize anything other than lighting rail fixtures on the rail. To reduce the risk of fire and electrical shock, do not attempt to connect power tools, extension cords, appliances, and the like to the rail.
10. This track system MUST BE HARD WIRED. For all the wire connections, use Listed Wire Nuts.
11. Secondary connections must be clean and tight to avoid arcing and overheating!
12. Warranty is void in case of unauthorized modifications and/ or improper use.

READ ALL OF THESE INSTALLATION INSTRUCTIONS BEFORE INSTALLING THE SYSTEM

Contents of Delivery:

- 1 39" V/A Track
- 1 150W Canopy
- 2 End Caps

Step 1 Mounting The Transformer

- Connect the wires (A) from the canopy to the power supply cables from the transformer. Insert the screws (B) into the mounting plate (C) and tighten.

- Place the cover (D) over the mounting plate (C) and secure it with the allen screw (E) located on the side of the base.

- Loosen the set screws (F), slide the track (H) through the power feed (G). Tighten the set screws (F) firmly.

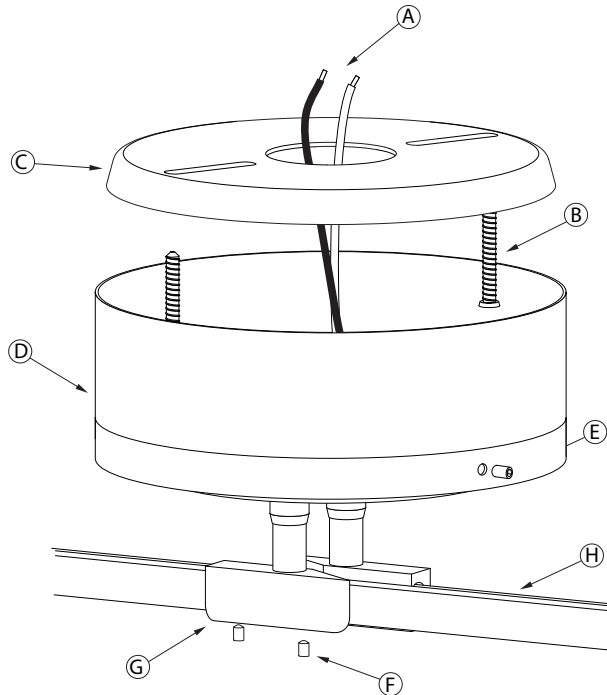

Step 2 End Cap

- Place end caps (K) on to track to complete track (J) installation.

